

USER INSTRUCTIONS & CUSTOMER CARE GUIDE
FLOOR STANDING RSF GAS-FIRED CONDENSING COMBINATION
BOILER

GREENSTAR
HIGHFLOW 440/550CDi

FOR SEALED CENTRAL HEATING SYSTEMS AND MAINS FED DOMESTIC HOT WATER

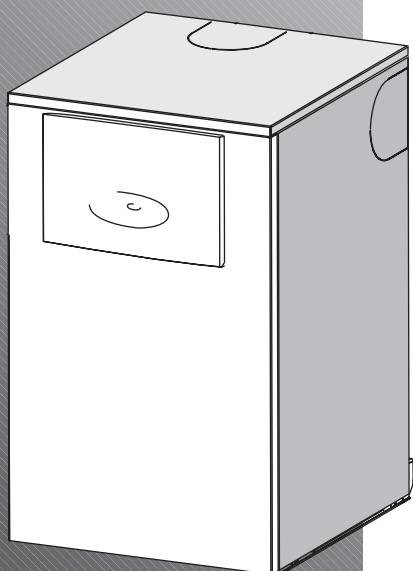

THE APPLIANCE IS FOR USE WITH
NATURAL GAS OR L.P.G. (Cat II 2H3P TYPE C13, C33 & C53)

NATURAL GAS:
GREENSTAR HIGHFLOW 440CDi GC NUMBER 47-406-24
GREENSTAR HIGHFLOW 550CDi GC NUMBER 47-406-25

LIQUID PETROLEUM GAS:
GREENSTAR HIGHFLOW 440CDi GC NUMBER 47-406-26
GREENSTAR HIGHFLOW 550CDi GC NUMBER 47-406-27

UK/IE

benchmark

WORCESTER
Bosch Group

CONTACT INFORMATION

WORCESTER BOSCH:

TECHNICAL: 08705 266241

SERVICE: 08457 256206

LITERATURE: 01905 752556

SALES: 01905 752640

WEBSITE: www.worcester-bosch.co.uk

USER INSTRUCTIONS & CUSTOMER CARE GUIDE

PLEASE READ THESE INSTRUCTIONS CAREFULLY BEFORE OPERATING YOUR BOILER

THESE INSTRUCTIONS ARE APPLICABLE TO THE WORCESTER, BOSCH GROUP BOILER MODEL(S) STATED ON THE FRONT COVER OF THIS MANUAL ONLY AND MUST NOT BE USED WITH ANY OTHER MAKE OR MODEL OF BOILER.

THE INSTRUCTIONS APPLY IN THE UK ONLY AND SHOULD BE FOLLOWED EXCEPT FOR ANY STATUTORY OBLIGATION.

IF YOU ARE IN ANY DOUBT CONTACT THE WORCESTER, BOSCH GROUP TECHNICAL SUPPORT.

DISTANCE LEARNING AND TRAINING COURSES ARE AVAILABLE FROM WORCESTER, BOSCH GROUP.

THIS BOILER MUST BE INSTALLED BY A CORGI REGISTERED, COMPETENT PERSON. FAILURE TO INSTALL CORRECTLY COULD LEAD TO PROSECUTION.

PLEASE LEAVE THIS GUIDE, THE INSTALLATION INSTRUCTIONS AND THE COMPLETED BENCHMARK CHECKLIST WITH THE USER.

NOTE: THE BENCHMARK CHECKLIST AND SERVICE INTERVAL RECORD CAN BE FOUND AT THE REAR OF THE INSTALLATION, COMMISSIONING AND SERVICE INSTRUCTIONS.

ABBREVIATIONS USED IN THIS BOOK:

NG - Natural Gas

LPG - Liquid Petroleum Gas

CH - Central Heating

SEDBUK - Seasonal Efficiency of Domestic Boilers in the United Kingdom

CONTENTS

INTRODUCTION

SAFETY PRECAUTIONS	2
GENERAL INFORMATION	3
GENERAL NOTES	4-5

USING YOUR APPLIANCE

CONTROLS	6-7
OPERATING THE APPLIANCE	
Switching the appliance on/off	8
Setting the central heating temperature	8
Controlling central heating	8
Frost protection	9
Controlling the hot water temperature	9
ECO indicator	9
Fault condition	10

MAINTENANCE

MAINTAINING YOUR BOILER	11
FAULT FINDING	12
FAULT OR BREAKDOWN	13

ENERGY SAVING

TIPS ON ENERGY SAVING	14-15
-----------------------	-------

GUARANTEE

YOUR GUARANTEE	16
GUARANTEE REGISTRATION	17

Dedicated to heating comfort

Thank you for purchasing a Greenstar gas-fired condensing combination boiler manufactured by Worcester, Bosch Group. The company prides itself on manufacturing boilers to the strictest quality control standards throughout every stage of production.

Worcester, Bosch Group has led the field in innovative boiler design and performance for more than 40 years. This heritage means all products are of exceptional quality and proven reliability.

The Greenstar range in particular is extremely energy efficient, offering you economical running costs and value for money. It sits in SEDBUK Band A, and is therefore amongst the top energy rated boilers available.

There is also the reassurance of our no-nonsense 2 years parts and labour guarantee - backed up by Worcester Total Cover, an optional complete maintenance scheme to keep your boiler operating at peak condition and efficiency.

To find out more about Worcester, Bosch Group log onto www.worcester-bosch.co.uk .

INTRODUCTION

USING YOUR APPLIANCE

ENERGY SAVING

MAINTENANCE

GUARANTEE

1

SAFETY PRECAUTIONS

IF YOU SMELL GAS:

- DON'T SMOKE OR STRIKE MATCHES.
- DON'T TURN ELECTRICAL SWITCHES ON OR OFF.

- DO PUT OUT NAKED FLAMES.
- DO OPEN DOORS AND WINDOWS.
- DO KEEP PEOPLE AWAY FROM THE AREA AFFECTED.
- DO TURN OFF THE CONTROL VALVE AT THE METER.

- DO CALL YOUR GAS COMPANY.

COMBUSTIBLE AND CORROSIVE MATERIALS:

Do not store or use any combustible materials (paper, thinners, paints etc.) inside or within the vicinity of the boiler.

Chemically aggressive substances can corrode the boiler and invalidate any warranty.

FITTING & MODIFICATIONS

Fitting the boiler, any controls to the boiler and removal of the outer casing may only be carried out by a competent engineer in accordance with the Gas Safety (Installation and Use) Regulations.

Flue systems must not be modified in any way other than as described in the Installation instructions and any misuse or unauthorised modifications to the boiler, flue or associated components and systems could invalidate the warranty. The manufacturer accepts no liability arising from any such actions. This does not affect your statutory rights.

GENERAL INFORMATION

SERVICING

The boiler must be serviced regularly by a competent, qualified person, such as a Worcester service engineer or alternatively a British Gas or other CORGI registered person.

Always use original spares, to help maintain the economy, safety and reliability of the boiler and to have the Service Record completed in the Benchmark checklist.

IMPORTANT:- Ensure that the service engineer completes the Service Record in the Benchmark checklist after each service.
The completed Benchmark checklist will be required in the event of any warranty work and may be required by the local Building Control Inspector.

NOTE: The Benchmark checklist and service interval record can be found at the rear of the Installation, Commissioning and Servicing Instructions.

BENCHMARK STANDARD

'Benchmark' is a code of practice for correctly installing, commissioning and servicing of domestic water heating boilers.

A Benchmark Checklist is provided by the manufacturer for the installer to complete ALL details together with their CORGI registration number and sign to confirm that the boiler has been installed and commissioned according to the manufacturer's instructions.

HEALTH & SAFETY

The boiler contains no asbestos and no substances used in the construction process that contravene the COSHH Regulations (Control of Substances Hazardous to Health Regulations 1988).

GENERAL NOTES

To get the best from your boiler please read these instructions carefully.

SEALED HEATING SYSTEMS

This boiler is fitted to a sealed heating system which is pre-pressurised. Your installer will advise you of the minimum and maximum pressure which should be indicated on the pressure gauge.

Check regularly that the pressure is maintained and contact your installer or maintenance engineer if a permanent significant drop in pressure is indicated on the pressure gauge. If the system loses pressure it should be re-pressurised and the cause of the fall investigated.

CENTRAL HEATING SYSTEMS

During the first few hours of operation of the central heating system, check that all radiators are being heated evenly. If the top of a radiator is at a lower temperature than the bottom then it should be vented by releasing air through the venting screw at the top of the radiator. Ask your installer to show you how this is done.

This boiler is fitted to a sealed system; repeated venting will reduce the quantity of water in the system and this must be replenished for safe and satisfactory operation of the boiler.

Should water leaks be found in the system or if excessive venting is required, then a service engineer must be contacted to inspect the installation and rectify any fault.

Only additives that are compatible with aluminium may be used in the system. Any incompatible additive used will invalidate the guarantee.

CONDENSATE DRAIN

This is a condensing boiler and the terminal will, at times give out a plume of water vapour. This is quite normal.

The boiler also produces quantities of condensate which is discharged regularly by a trap within the boiler via a pump and pipe to drain. This pipe must not be blocked or altered in any way.

CLEARANCES - SERVICE

Your installer will have provided adequate space around the boiler for safety and servicing access. Do not restrict this space with the addition of cupboards, shelves etc. next to the boiler.

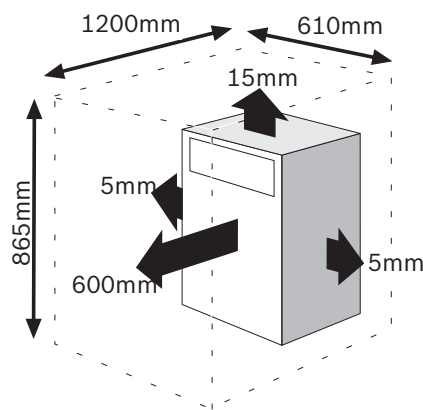

ROOM THERMOSTAT

A room temperature controller and programmer should be fitted to control the central heating. Refer to the instructions supplied with the thermostat for information on siting and setting.

THERMOSTATIC RADIATOR VALVES

RVs should be fitted to all but one of the radiators (or at least those in the sleeping accommodation). The radiator without the TRV must be in the same room as the room thermostat, and must be uncontrolled and unrestricted. The thermostatic radiator valves should conform to the requirements of BS2767:10.

GENERAL NOTES

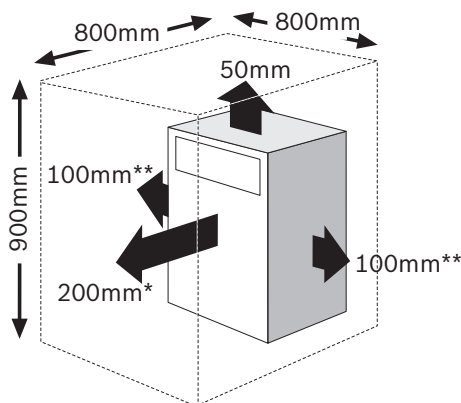
**BOILER CLEARANCES - UNVENTILATED COMPARTMENT**

The diagram opposite shows the minimum space required to install and service the boiler inside an unventilated compartment.

* Space required for unventilated areas with a removable door or panel, but 600mm to a fixed surface for servicing.

** This space can be reduced to 50mm for **one side only** as long as both side clearances add up to the total of both the side measurements shown, or more.

Two examples are shown opposite, refer to the 'Installation, commissioning and servicing instruction manual' for further information.

Do not add cupboards, shelves etc. to restrict the space around the boiler.

VENTILATION

This is a room sealed boiler and does not require any air for combustion from inside the property.

In spite of the requirements of BS 6798 and BS 5440 there is no need for ventilation openings to be provided in the compartment because of the low heat loss from the boiler casing, if the clearances shown are maintained.

BOILER CLEARANCES -**AIRING CUPBOARD**

If the boiler is fitted into an airing cupboard then the diagram opposite shows the minimum clearances required around the boiler and also the clearances for any shelf constructed above the boiler.

If a compartment is built around the boiler after installation, then the compartment must be separated from the boiler space by a non-combustible partition as described in BS 6798.

WARNING

Do not operate the boiler if the flue terminal fitted on the outside wall or roof is obstructed or damaged.

PUMP ANTI-SEIZURE

If there has been no heating demand for 24 hours, the boiler will run the system pump for a few seconds. This is to reduce the possibility of pump seizure during long periods of inactivity which are usually more frequent during the summer months.

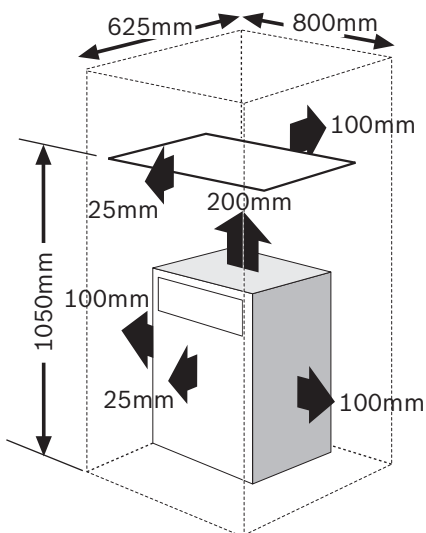

CONTROLS

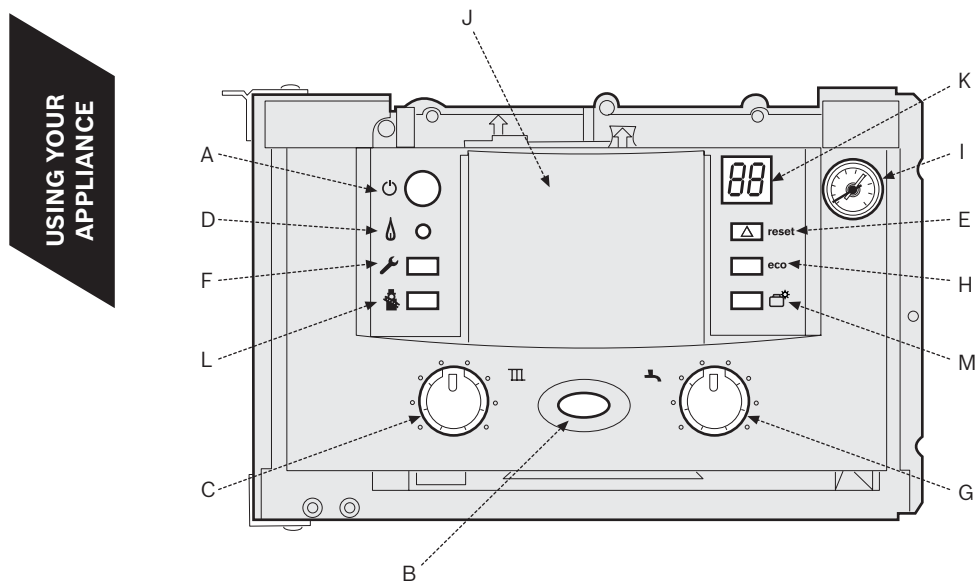

USING YOUR
APPLIANCE

- A - MASTER SWITCH FOR ON/OFF
- B - MAINS ON/OFF INDICATOR + FAULT DIAGNOSTIC LIGHT
- C - CENTRAL HEATING TEMPERATURE CONTROL
- D - BURNER ON INDICATOR LIGHT (GREEN)
- E - FAULT RESET BUTTON
- F - SERVICE BUTTON
- G - DOMESTIC HOT WATER TEMPERATURE CONTROL
- H - ECO BUTTON
- I - SYSTEM PRESSURE GAUGE
- J - POSITION FOR OPTIONAL PROGRAMMER
- K - DISPLAY
- L - CENTRAL HEATING BOOST BUTTON
- M - NOT USED

CONTROLS

TO ACCESS THE CONTROLS

- ▶ Pull the centre top of the cover panel to allow the cover to open.

TO ACCESS THE FILLING LOOP CONNECTION

- ▶ Pull the front panel away from the boiler and lift up.

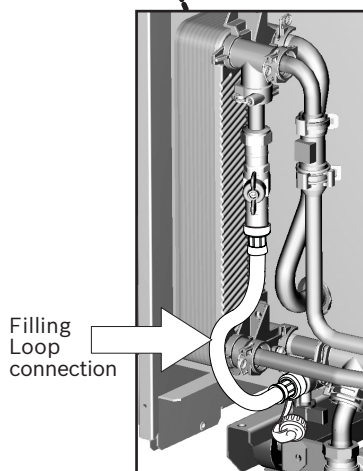
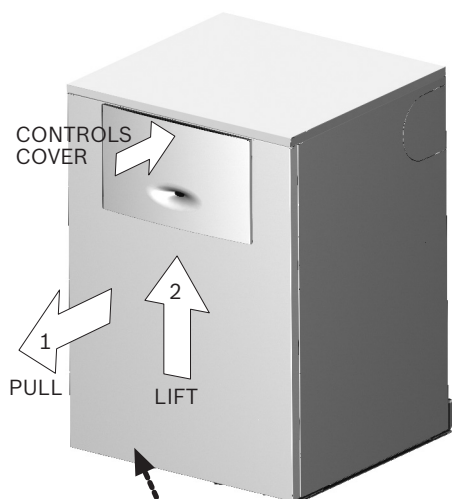

USING YOUR
APPLIANCE

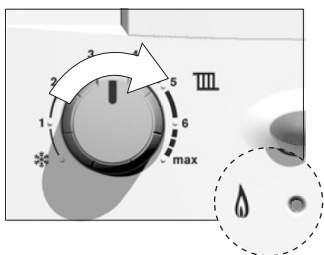
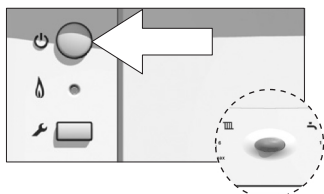

APPROXIMATE TEMPERATURES

*	---	OFF
1	---	35 °C
2	---	40 °C
3	---	50 °C
4	---	65 °C
5	---	75 °C
6	---	85 °C
Max	---	88 °C

OPERATING THE APPLIANCE

SWITCHING THE APPLIANCE ON/OFF

Switching on

- ▶ Switch on the appliance by pressing the master switch.

The indicator light shows blue

- The boiler runs for 15 minutes at minimum heating output to fill the condensate trap, the display (K) alternates between '-II-' and the central heating flow temperature. This occurs every time the mains supply has been interrupted.

Switching off

- ▶ Switch off the appliance by pressing the master switch. The blue indicator light goes out.

SETTING THE CENTRAL HEATING TEMPERATURE

- ▶ Turn the central heating temperature control to the desired level, between 35°C and 88°C.
- ▶ When the burner is lit, the green indicator light underneath the on/off switch is illuminated.

CONTROLLING CENTRAL HEATING

- ▶ Set the timer to the correct time.
- ▶ Set room thermostat to the desired room temperature.
- ▶ Set the thermostatic radiator valves to the desired settings.

OPERATING THE APPLIANCE

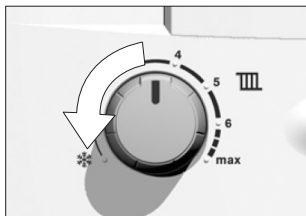

APPROXIMATE TEMPERATURES

Min.	...	45 °C
1	...	50 °C
2	...	52 °C
3	...	54 °C
4	...	56 °C
5	...	58 °C
6	...	60 °C
Max.	...	65 °C

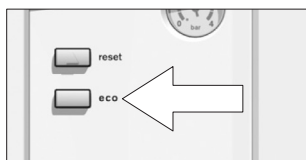

FROST PROTECTION

If heating is NOT required:

- ▶ Leave master switch on.
- ▶ Turn the central heating temperature control to

If the temperature falls to 5 °C inside the boiler, the boiler will fire to prevent the possibility of freezing.

- ▶ Add a suitable anti-freeze fluid to the water in the central heating system.
- ▶ If remote pipework is likely to be subjected to freezing conditions, ensure the installer has fitted a frost thermostat in the area to protect the pipework.

CONTROLLING THE HOT WATER TEMPERATURE

- ▶ The hot water temperature can be set to between approx. 45 °C and 65 °C using the temperature control

ECO INDICATOR

NOTE: If your boiler has an in-built fascia mounted programmer and the mains supply is interrupted, the ECO button will need to be reset by pressing and holding for three seconds.

When the ECO button **IS** lit the pre-heated tank of hot water is turned off, but the boiler will supply hot water as a normal Combi boiler. It will take longer to obtain hot water at the tap in ECO mode as the boiler is not maintaining a supply of hot water for immediate use.

When the ECO button is **NOT** lit the boiler is in pre-heat mode for hot water.

Hot water will now be available at the tap almost immediately as the boiler constantly maintains a tank of hot water ready for use.

USING YOUR APPLIANCE

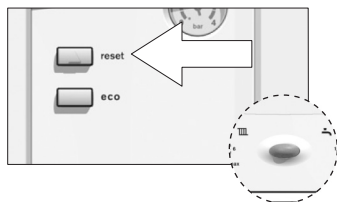

OPERATING THE APPLIANCE

FAULT CONDITION

In the unlikely event of a fault occurring while the appliance is in operation:

The reset button will flash once per second and the mains indicator (blue light) will flash also. The display shows a fault code.

► To reset boiler press the reset button.

The reset button will no longer be illuminated and the mains indicator will stop flashing.

The boiler will function normally, dependent on programmer and room thermostat settings.

If the fault remains and cannot be cleared by pressing the reset button, or if fault persists contact British Gas for assistance, giving a description of the fault and, if possible, the fault code from the display.

MAINTAINING YOUR BOILER

Your new Greenstar gas-fired boiler represents a long term investment in a reliable, high quality product.

In order to realise its maximum working life, and to ensure it continues to operate at peak efficiency and performance, it is essential that your boiler receives regular servicing and maintenance checks from a competent person beyond the initial 2 year guarantee period.

If you would like to know more about a Worcester, Bosch Group service contract, please tick the appropriate box on your warranty registration card.

If your Greenstar gas-fired boiler should fail to operate correctly or requires servicing please contact the Worcester, Bosch Group Service Department (see inside front cover for details).

Details of the boiler including the Gas Council number can be found under the controls cover flap on the boiler.

MAINTENANCE

FAULT FINDING

This table gives information on basic operating system problems.

In the unlikely event of a boiler fault please read the following page thoroughly before contacting Worcester, Bosch Group.

PROBLEM	CAUSE	REMEDY
Desired room temperature is not reached	Thermostatic radiator valve(s) set too low	Increase thermostatic radiator valve setting(s)
	Temperature control for CH flow on boiler set too low	Increase CH flow temperature control setting
	Air trapped in heating system	Bleed radiators and recharge heating system
Desired room temperature exceeded by large amount	Radiators are too hot	Turn down thermostatic radiator valves / room thermostat Reduce central heating temperature on boiler
Heating stays on for too long	Clock is incorrectly set	Check setting
No on/off indicator	Momentary power failure	Switch off boiler at master switch, wait a few seconds then switch on again
Hot water temperature too low	Temperature set too low Programmer setting Water flow at tap too high	Check setting Check setting Reduce flow rate at tap
Hot water temperature too high	Temperature set too high	Check setting

MAINTENANCE

FAULT OR BREAKDOWN

This boiler is supported in the UK and Eire by Worcester, Bosch Group.

Specially trained, Worcester, Bosch Group Service Engineers are available to attend a breakdown occurring on this boiler.

No charge will be made for parts and/or labour providing:

An boiler fault is found and the boiler has been installed within the past 24 months.

Reasonable evidence of this must be supplied on request. i.e. the Benchmark Checklist.

A call-out charge will be made where:

The boiler has been installed for over 24 months.

OR

Evidence cannot be provided that the first year service inspection has been carried out (i.e. an entry in the Benchmark Checklist).

OR

Our Field Service Engineer finds no fault with the boiler (see Note).

OR

The cause of breakdown is misuse or with other parts of your plumbing/heating system, or with equipment not supplied by Worcester, Bosch Group.

NOTE: NO BOILER FAULT IS FOUND ON OVER 30% OF SERVICE CALL OUTS.

Please read this guide carefully to gain a good understanding of the operation of your boiler.

In the case of a suspected fault, refer to the fault finding section of this guide.

If in doubt contact our Technical Support

In the event of an boiler fault or breakdown please contact our Service Department. Your service administrator will arrange for an engineer to call with the minimum of delay; under normal circumstances this will be from 1 - 3 working days (excluding weekends) for priority breakdown situations (no hot water and/or heating).

Invoices for attendance and repair work carried out on this boiler by any third party will not be accepted.

MAINTENANCE

TIPS ON ENERGY SAVING

HEATING ECONOMICALLY

The boiler is designed to provide a high level of comfort while keeping gas consumption and the resulting environmental effect as low as possible. The gas supply to the burner is controlled according to the level of demand for heat. The boiler continues to operate with a low flame if the demand for heat reduces. The technical term for this process is modulating control. Modulating control reduces temperature fluctuations and provides even distribution of heat throughout the home. This means that the boiler may stay on for relatively long periods but will use less gas than a boiler that continually switches on and off.

CENTRAL HEATING SYSTEMS WITH ROOM THERMOSTATS/THERMOSTATIC RADIATOR VALVES

The temperature control on the boiler should be set to the maximum.

The temperature of each room can be set individually (except primary room with the room thermostat) using the thermostatic radiator valves.

ENERGY
SAVING

ROOF INSULATION

Around 30% of the heat loss from a property is through the roof. Replace any old insulation with new insulation, preferably of around 200mm thickness or more.

WINDOW FRAMES

Single glazed windows, particularly those with steel frames, can lose a great deal of heat. Consideration should be given to replacement with PVCu or wooden framed double glazed units.

CURTAINS

Lined curtains, or heavier full length curtains can provide excellent insulation. However, always ensure that the curtains do not drape over radiators.

TIPS ON ENERGY SAVING

DRAUGHTS

Try to ensure that draughts around doors, windows, letterboxes and keyholes etc. are reduced by using a suitable draught excluder. Warning - Do not block or seal any air vents that are installed to ensure the central heating boiler operates safely.

ROOM THERMOSTATS

Reducing the setting of the room thermostat by 1°C can reduce fuel consumption by up to 10%.

NEW CONTROL SYSTEMS

Upgrade your heating control system if necessary with the latest equipment available. The minimum level of control is a programmer, interlocking room thermostat and thermostatic radiator valves.

RADIATORS

More often than not radiators will be sited underneath a window, so the warm air from the radiator heats the colder incoming air from the window. The performance of the radiator will be affected if the curtains are allowed to drape over the radiator or shelves are fitted above it. The positioning of furniture and tables in front of the radiator should also be avoided.

It is advisable to manually adjust all radiator thermostatic valves every 2-3 months to prevent them sticking. It is also important that the plastic tops of all valves are always in position and not cracked or damaged to prevent accidents. Care should be taken when vacuum cleaning carpets to avoid damage to valves and pipework.

The heating system and the outputs of the radiators have been carefully selected by your installer. The temperature obtainable in any given room is dependent on all radiators being operated at the same time. If you decide to turn off radiators in unused rooms, spare bedrooms etc., you may experience slightly lower room temperatures in rooms adjacent to unheated rooms.

ENERGY
SAVING

YOUR GUARANTEE

- ▶ This boiler is guaranteed against faulty material or workmanship for a period of 2 years from the date of installation subject to the following terms and conditions:
- ▶ Your Guarantee Registration Card must be returned within 30 days for the second year of your guarantee to become valid.
- ▶ During the period of this guarantee any components of the unit which are proven to be faulty or defective in manufacture will be exchanged or repaired free of charge by Bosch Thermotechnology Ltd.
- ▶ The householder may be asked to prove the date of installation, that the boiler was correctly commissioned and, where appropriate, the first year's service inspection has been carried out to the satisfaction of Bosch Thermotechnology Ltd., when requested. These should be part of the Benchmark Checklist.
- ▶ Any product or part returned for servicing under the guarantee must be accompanied by a claim stating the model, serial number & date of installation.
- ▶ Bosch Thermotechnology Ltd., will not accept responsibility for damage caused by faulty installation, neglect, misuse or accidental damage or the non-observance of the instructions contained in the Installation Commissioning and Servicing Instructions and User Instructions and Customer Care Guide.
- ▶ The boiler has been used only for the normal domestic purposes for which it was designed.
- ▶ This guarantee does not affect your statutory rights. Your Guarantee Registration Card must be returned within 30 days for the second year of your guarantee to become valid.
- ▶ This guarantee applies only to equipment purchased and used in the United Kingdom and Eire.
- ▶ This guarantee does not affect your statutory rights.

GUARANTEE REGISTRATION

You should complete and return the postpaid Guarantee Registration Card within 30 days of purchase.

Returning the card will register you as the owner of your new Greenstar boiler and will assist us in maintaining an effective and efficient customer service by establishing a reference and permanent record for your boiler.

This does not affect your statutory rights.

For your own record:

MODEL: _____

SERIAL No. _____

(See identity label inside the appliance casing)

TYPE / SIZE: _____

DATE OF INSTALLATION: _____

NAME OF INSTALLER: _____

TELEPHONE NUMBER OF INSTALLER: _____

Please ensure that the Benchmark Checklist has been completed by your installer or service engineer.

GUARANTEE

Dedicated to heating comfort

Worcester, Bosch Group

Cotswold Way, Warndon, Worcester WR4 9SW

Tel. 01905 754624 Fax. 01905 754619

Worcester, Bosch Group is a brand name of
Bosch Thermotechnology Ltd.

worcester-bosch.co.uk

8 716 115 220a (07.2008)

