

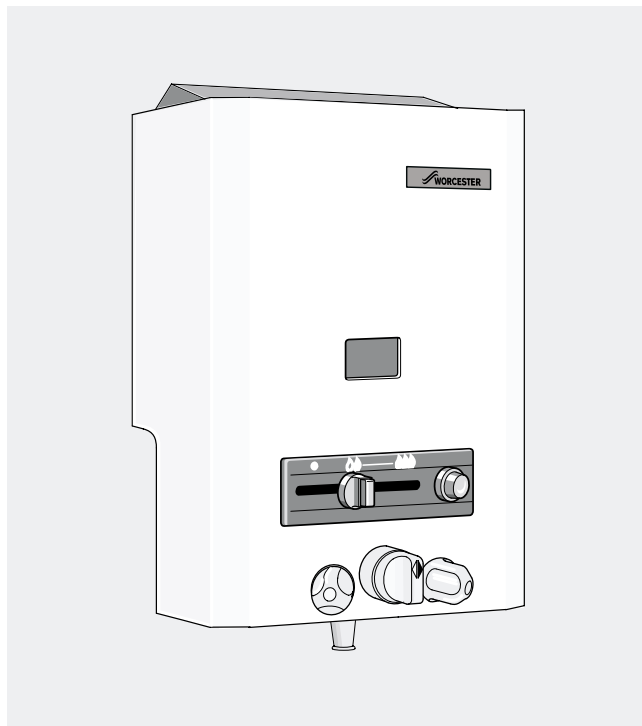

W 125 FL

Flueless Singlepoint Water Heater
with Atmosphere - Sensing Device

INSTALLATION AND SERVICING INSTRUCTIONS



G.C. N° 52-311-022

For your safety - if you smell gas:

1. Turn off the appliance
2. Open all windows and doors
3. Do not operate any electrical switches
4. Extinguish all naked flames
5. Contact the local Gas Region immediately

This appliance conforms to European Standard EN 26.

It is the law that all gas appliances are installed by competent persons.

The following instructions should be read carefully as the manufacturer cannot be held responsible for any damage to property, persons or animals caused by incorrect installation or operation of the appliance.

It is recommended that the appliance be serviced annually by a competent person or the local Gas Region.

The Users Instructions should be handed to the user and the function and operation of the appliance explained.

CONTENTS

	page		page
1	Installation Regulations 2	7	Installation 6
2	General information 2	8	Commissioning 6
3	Technical Data 5	9	Inspection and Service 7
4	Siting the appliance 5	10	Replacement of parts 8
5	Air supply 5	11	Spare parts 10
6	Gas supply 6	12	Fault Finding 11

1 Installation Regulations

1.1 Gas Safety (Installation and Use) Regulations 1998. All gas appliances must be installed by a competent person in accordance with the above regulations. Failure to install appliances correctly could lead to prosecution.

1.2 The manufacturers notes must not be taken, in any way, as overriding statutory obligations.

1.3 The compliance with a British Standard does not, of itself, confer immunity from legal obligations. In particular the installation of this appliance must be in accordance with the relevant requirements of the Gas Safety (Installation and Use) Regulations 1998 (as amended), local Building Regulations, Building Standards (Scotland) (Consolidation), byelaws of the local Water Company and Health and Safety Document No. 635 (Electricity at Work Regulations 1989). It should be in accordance with the relevant recommendations of the following British Standards:

BS 6798:1987 Specification for Installation of gas fired hot water boilers of rated input not exceeding 60 kW.

BS 5546:1990 Installation of gas hot water supplies for domestic purposes.

BS 5440:2:1989 Flues and ventilation for gas appliances of rated input not exceeding 60 kW: Air Supply.

BS 6891:1988 Installation of low pressure gas pipework installations up to 28 mm (R1).

1.4 To ensure that the installation will perform to the highest standards, the system and components should conform to any other relevant British Standards in addition to those mentioned in the instructions.

2 General Information

2.1 This appliance is available for use with natural gas. When installing the appliance for use with natural gas, please check 10 digit number on carton to ensure that the correct appliance has been specified. The 10 digit number for a natural gas appliance is 7 700 352 952.

2.2 This appliance is available for use with LPG. When installing the appliance for use with LPG, please check 10 digit number on carton to ensure that the correct appliance has been specified. The 10 digit number for an LPG appliance is 7 700 452 908.

2.3 This appliance is not suitable for external installation.

2.4 The appliance is set to provide a maximum output of 8.7 kW and a minimum output of 4.4 kW.

2.5 The appliance has a permanent pilot.

2.6 PRINCIPLE APPLIANCE COMPONENTS

- A low thermal capacity Gas to Water heat exchanger.
- A stainless steel main gas burner.
- A gas section.
- A water section.
- A thermoelectric safety valve.

2.7 GENERAL INSTALLATION

The appliance must be installed in the same room as the water draw-off point.

The appliance must not be installed in a room where the volume is less than 5m³.

The appliance must not be installed in a compartment or roof-space or in a room which may be incorporated in a protected shaft / stairway.

2.8 FLUE

This appliance is flueless, hence it is essential that the correct installation requirements are satisfied. This appliance is intended for intermittent use only, and **must not** be positioned in or adjacent to a bedroom or any room containing a bath or a shower.

2.9 SAFETY FEATURES

The Worcester W 125 is fitted with an atmosphere-Sensing Device which must not be altered in any way.

1.) If the air in the room in which the heater is situated becomes depleted of oxygen the pilot will be extinguished automatically.

2.) If the flue outlet is obscured or the heat exchanger becomes blocked again the pilot will be extinguished automatically.

Appliance water flow diagram.

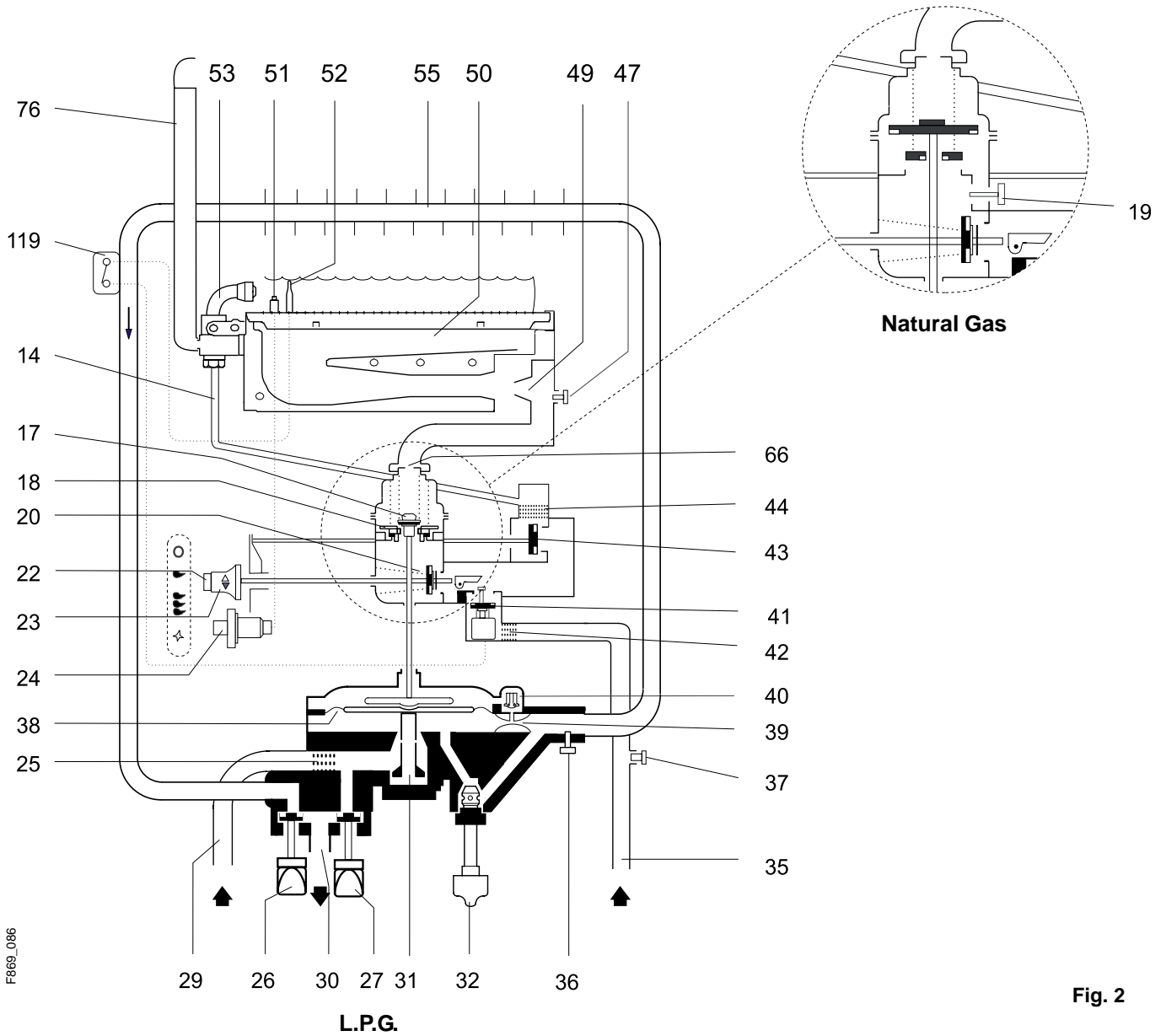

F869_086

Fig. 2

- | | | |
|----------------------------|----------------------------------|-------------------------------|
| 14 Pilot gas pipe | 30 Hot water outlet | 44 Pilot gas filter |
| 17 Large poppet valve | 31 Volumetric water governor | 47 Burner pressure test point |
| 18 Small poppet valve | 32 Temperature selector | 49 Burner injector |
| 19 Cross-ignition bolt | 35 Gas inlet pipe | 50 Main burner |
| 20 Main gas valve | 36 Sealing screw | 51 Spark electrode |
| 22 Pilot gas button | 37 Inlet gas pressure test point | 52 Thermocouple |
| 23 Gas control slide | 38 Diaphragm | 53 Pilot burner |
| 24 Piezo igniter | 39 Venturi | 55 Heat exchanger |
| 25 Water filter | 40 Slow ignition valve | 66 Throttle plate |
| 26 Hot water tap | 41 Electromagnetic valve | 76 Atmosphere sensing device |
| 27 Cold water tap | 42 Gas filter | 119 Temperature limiter |
| 29 Cold water pipe (inlet) | 43 Pilot gas valve | |

Dimensions (in mm)

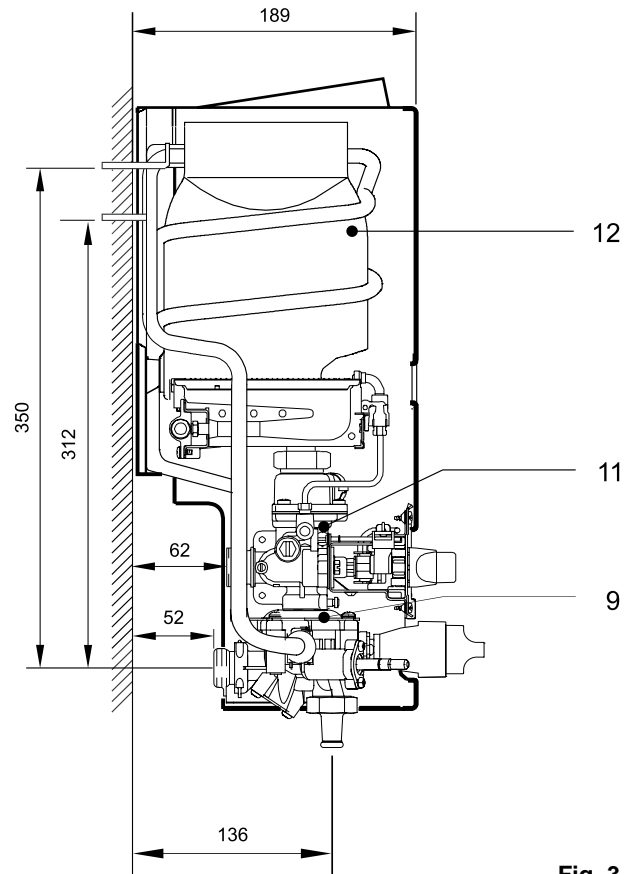
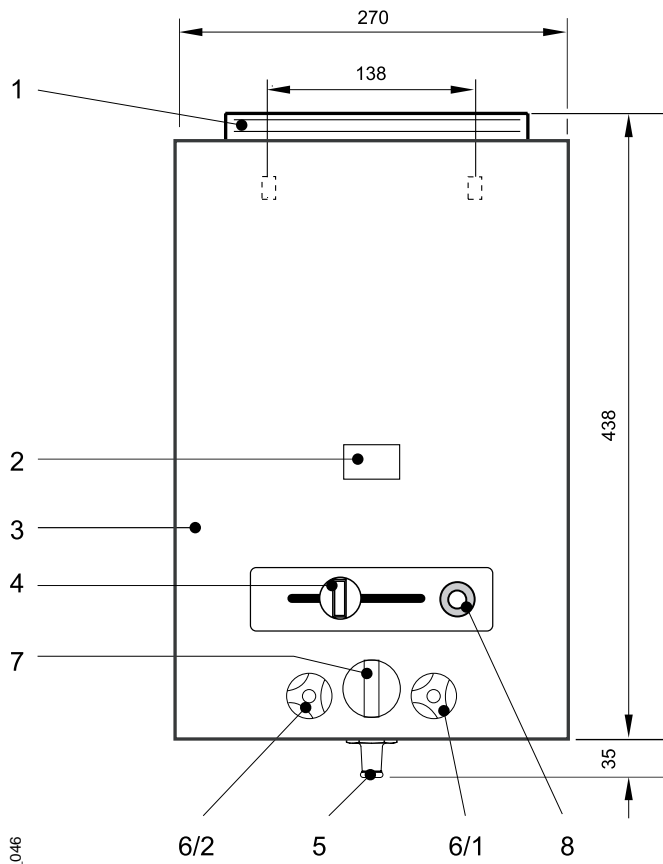

Fig. 3

- | | |
|------------------------|------------------------|
| 1 Flue gas deflector | 6/2 Hot water tap |
| 2 Observation window | 7 Temperature selector |
| 3 Front cover | 8 Piezo ignitor |
| 4 Output slide control | 9 Water valve assembly |
| 5 Water outlet | 11 Gas valve assembly |
| 6/1 Cold water tap | 12 Heat exchanger |

D770_046

3 Technical Data

Table 1 - GENERAL

	Natural Gas	LPG
Minimum rated output (Pmin)	4.4 kW	4.4 kW
Maximum rated output (Pn)	8.7 kW	8.7 kW
Rated input (Qn)	10.4 kW	10.4 kW
Gas rate (maximum)	1.1 m ³ /h	0.8 kg/h
Number of injectors	8	8
Injector diameter (mm)	1.1	0.70
Pilot injector marking	111	70
Burner pressure	9 mbar	15 mbar
Height (mm)	438	438
Width (mm)	270	270
Depth (mm)	189	189
Dry weight	7.0 kg	7.0 kg

Table 2 - PERFORMANCE

Maximum cold water supply inlet pressure	12 bar (180 p.s.i.)
Minimum cold water supply inlet pressure to operate the appliance	0.15 bar (1.5 p.s.i.)
Minimum cold water supply inlet pressure for maximum domestic hot water flow	0.6 bar (9 p.s.i.)
Domestic hot water delivery with temperature control knob fully anticlockwise	5 litres/minute at 25°C temperature rise
Domestic hot water delivery with temperature control knob fully clockwise	2.5 litres/minute at 55°C temperature rise

4 Sitting the appliance

4.1 The appliance may be installed in any room with the exception of a bedroom or any room containing a bath or a shower.

4.2 The appliance is not suitable for external installation.

4.3 The appliance does not require any special wall protection.

4.4 The wall must be capable of supporting the weight of the appliance. See Technical Data – Table 1.

4.5 If the appliance is to be fitted in a timber framed building, refer to the British Gas Publication "Guide for gas installations in timber framed housing".

4.6 The following clearances must be available for installation and for servicing:

Above	300 mm
In front	600 mm
Below	150 mm
Right hand side	10 mm
Left hand side	10 mm

4.7 The appliance must NOT be installed in a room having a volume of less than 5.0m³.

4.8 No combustible surface must be within 75 mm of the casing. See BS 476:4.

5 Air supply

5.1 The appliance is a flueless appliance and requires permanent ventilation in accordance with the following details.

5.2 A permanent air vent shall be provided. This permanent opening shall be direct to outside air and in accordance with the following table.

The values given are the minimum required.

Ventilation Requirements cm ² Flueless Appliances			Openable window or equivalent reqd.
Room Volume			
5.0 to 10.0 m ³	11.0 to 20.0 m ³	Above 20.0 m ³	Yes
100	50	nil	

5.3 Where an extract fan is fitted additional air vents shall be provided. As a general guide an extra 50 cm² of air vent free area will be sufficient for most situations.

5.4 Refer to BS 6798 and BS 5440 part 2 for additional information.

6 Gas supply

The appliance requires 1.1 m³/hr of gas. The gas meter and supply pipes must be capable of supplying this quantity of gas in addition to the demand from any other appliances being served. Refer to BS 6891 for further information.

The meter governor should deliver a dynamic pressure of 20 mbar (8 in w.g.) at the appliance.

The complete installation, including the gas meter, must be tested for soundness and purged. Refer to BS 6891.

A gas service cock must be fitted before each appliance, a gas service cock is supplied with every appliance.

Important: if the 1.1 m³/hr gas rate to the appliance cannot be reached, the specified hot water conditions will not be achieved. This could result in customer complaints. Always ensure that the gas supply is adequate.

7 Installation

The installation must be carried out by competent persons. On delivery, check to make sure that the packaging has not been damaged. If there is evidence of damage, contact your supplier immediately.

Check the 10 digit code number on the appliance carton to ensure that the correct appliance for the gas supply has been supplied.

The code number for a natural gas appliance is 7 700 352 952. The code number for an LPG appliance is 7 700 452 908.

7.1 Appliance Installation

- a) Unpack the appliance and take care to remove the installation kit which is packed on top of the polystyrene packing

The kit comprises of the following:

- One gas service cock with fibre washer
- One cold water isolating cock complete with fibre washer
- One water discharge pipe complete with brass swivel union
- Two fixing screws and wall plugs.

- b) Lay the appliance on its back and pull off the Hot and Cold water control Knobs and the Temperature control knob. Unscrew the temperature control outer bezel to release the casing from the appliance. Lift up the lower front edge of the case and slide towards the top of the heater to unhook the case from the back panel.

- c) Offer up the appliance to the wall and mark the positions for the two fixing screws. Drill two holes and fit the wall plugs and screws.

Hang the appliance on the fixing hooks and secure the appliance back panel to the wall through one of the two holes located at the lower left hand side of the panel.

- d) Make up the gas supply to the upper connection on the gas control assembly using the fibre washer provided. Fit the gas isolation cock as close as possible to the appliance (see fig. 4, pos. 1).

- e) Connect the appliance to the incoming cold water supply via the fitting which includes the stop valve. A fibre washer is provided (see fig. 4, pos. 2).

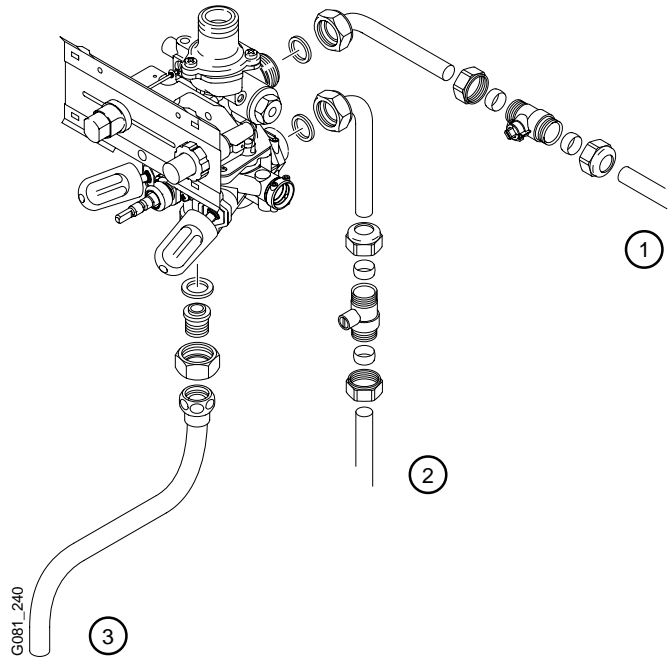

Fig. 4

- f) Fit the brass union for the water discharge pipe to the water control valve outlet using the fibre washer provided. Fit the chrome plated discharge pipe to the union and tighten sufficiently to allow the pipe to swivel (see fig. 4, pos. 3).
- g) Turn on the water supply to the appliance. Open the stop valve on the inlet fitting to the appliance and the open the hot and cold water taps. Allow water to flow to vent the system and close the taps.
- h) If the appliance is not to be commissioned straight away, re-fit the appliance casing and control knobs.

8 Commissioning

Before commissioning the appliance, the whole gas installation must be purged and tested for gas soundness in accordance with the current edition of BS 6891.

Important: Open all doors and windows. Extinguish naked lights and do not smoke while purging the gas line.

Proceed as follows.

- a) Ensure that the gas service cock in the gas inlet pipe is turned off.
- b) Remove the appliance casing as described in section 7 above.
- c) Loosen screw A and connect a pressure gauge to the test point. See fig. 5.

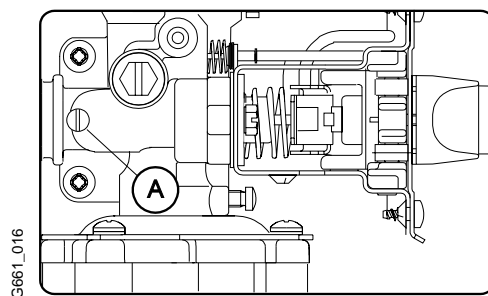

Fig. 5

- d) Turn on the gas service cock.
- e) Move the gas control slide to the ignition position. See fig. 6.

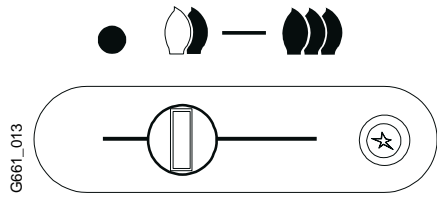

Fig. 6

Observe the pilot burner. Press in the central button of the control slider and hold depressed while pushing the Piezo igniter button two or three times. The pilot should light. Wait approximately twenty seconds and then release the centre button of the control slider. The pilot should remain alight. If the pilot does not light, repeat the operation until a flame is established.

- Note: On initial light up, or after any prolonged shut down, the pilot may take several attempts to establish due to the presence of air in the gas supply system. The pilot flame should envelope approximately 5 mm of the thermocouple head.
- f) Move the control slider fully to the right for maximum output, see fig. 7. Fully open the hot water tap. The main burner should light.

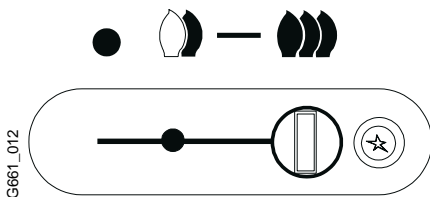

Fig. 7

- g) Check the dynamic inlet gas pressure. For Natural Gas the inlet pressure should be 20.0 mbar and for LPG the pressure should be 28.0 mbar (Butane) or 37.0 mbar (Propane). If the pressure is not correct then check the gas supply to the appliance. If the pressure is correct then turn off the hot water tap and move the slider to the off position, see fig. 8.

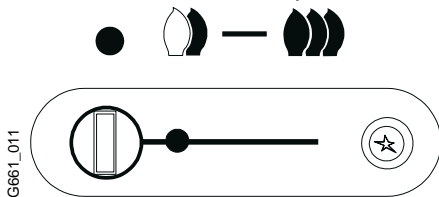

Fig. 8

Turn off the gas service cock. Remove the pressure gauge and tighten screw A, see fig. 5.

- h) Loosen screw D and connect the pressure gauge to the test point, see fig. 9.

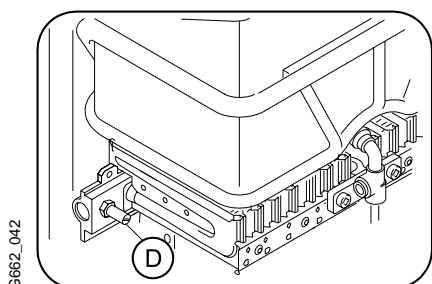

Fig. 9

Re-light the appliance as described above. Turn the temperature control to maximum.

- i) Operate the appliance for at least two minutes, then check that the burner pressure is as stated in Technical Data – Table 1.
- j) Turn off the hot water tap. Close the gas service cock. Remove the pressure gauge and tighten screw D.
- k) Re-fit the appliance casing and secure by re-fitting the temperature control bezel. Fit the temperature control knob and the hot and cold water tap knobs.
- l) On completion of the commissioning and testing of the system, the installer should hand over the appliance to the user with reference to the following.
 - 1) Give the Users Operating Instructions leaflet to the user.
 - 2) Explain and demonstrate the lighting and shutdown procedures.
 - 3) Advise the user of the precautions necessary to prevent damage to the system and to the building in the event of the system remaining inoperative during frost conditions.
 - 4) Stress the importance of an annual service by a competent person.

9. Inspection and Service

To ensure continued efficient operation of the appliance, it is recommended that it is checked and serviced as necessary at regular intervals.

The frequency of servicing will depend upon the particular installation conditions and usage but in general once a year should be adequate.

It is the law that any service work must be carried out by a competent person such as British Gas or other Corgi registered personnel.

Before commencing any service operation turn off the gas supply at the main gas service cock. Carry out the service operation as follows.

9.1 Remove the front casing by first removing the temperature control knob and the two water tap knobs. Unscrew the temperature control knob bezel and remove to release the appliance casing. Pull forward the lower front of the casing to clear the tap spindles and lift up the casing to unhook it from the appliance back plate.

9.2 Heat Exchanger

Inspect and clean the heat exchanger flueways as necessary.

To remove the heat exchanger, isolate the appliance from incoming cold water supply at the inlet cock. Open the taps to release any remaining water pressure and drain the appliance.

Undo the brass union nut on the pilot air supply pipe and withdraw the pipe from the air inlet collector.

Disconnect the push on terminals from the overheat thermostat at the top of the heat exchanger.

Pull out the retaining clips at the inlet and outlet connections on the water control body, and spring out the copper inlet and outlet pipes from the control body.

Take care not to damage the two 'O' ring seals. Unscrew the large heat exchanger retaining screw, located at the rear of the combustion chamber just above the burner blades, and lift clear the heat exchanger assembly. In hard water areas it may be necessary to descale the heat exchanger body. A proprietary brand of descaler should be used. Fill the heat exchanger with this solution and leave until the solution stops bubbling. Drain and thoroughly wash out the exchanger with clean water.

Warning: Acid/water solutions must be used with extreme caution. Take care not to splash on to the skin or into the eyes. Wash any affected areas with large amounts of cold water and seek medical advice.

Re-assemble in reverse order taking care to locate the heat exchanger on the two support hooks formed in the appliance back plate.

9.3 Pilot Assembly

Remove the appliance casing as described above. Remove the pilot air supply pipe as described above. Undo the union connection on the pilot gas pipe at the pilot body. Undo the two screws securing the pilot body to the burner front rail and withdraw outwards and upwards away from the pilot gas pipe.

Note: take great care to retain the pilot injector located between the end of the pilot gas pipe and the inside of the pilot body.

Inspect, clean and adjust as required.

Re-assemble in reverse order taking care to locate the pilot injector correctly.

9.4 Main Burner

Remove the appliance casing and pilot assembly as described in sections 9.1 and 9.3 above.

Slacken the pilot pipe union at the gas valve end and swing the pilot pipe to the left.

Undo the brass union nut holding the burner assembly to the gas valve body.

To remove the assembly from the combustion chamber it must be turned upside down. Proceed as follows.

Raise the front edge of the burner up into the combustion chamber turning over away from the front. Once the burner is upside down it can be withdrawn from under the combustion chamber, the union passing through cut-away in the front of combustion chamber. Inspect and clean as required. Check the union joint ring and replace if required.

Replace in reverse order taking care that the locating pin in the rear of the burner locates with the slot in the rear frame.

9.5 Final Inspection

Turn on the gas supply at the main gas service cock and check for gas soundness in accordance with the current edition of BS 6891 while the appliance is running.

Re-commission the appliance as described in section 8.

10 Replacement of Parts

The law requires that any service work must be carried out by a competent person such as British Gas or other Corgi registered personnel.

Before commencing any service operation turn off the gas supply at the main gas service cock.

10.1 Pilot Burner / Injector

Remove the appliance casing as described in section 9.1 above.

Remove the pilot assembly pipe as described in section 9.3 above.

Remove the retaining clip, holding the ignition electrode and thermocouple to the body, from the side of pilot burner body to release the electrode and thermocouple. Fit the new injector and/or pilot burner in reverse order.

10.2 Ignition Electrode / Thermocouple

Follow the instructions given above in section 10.1 and replace the faulty components.

10.3 Main Burner

Remove the appliance casing and pilot assembly as described in sections 9.1 and 9.3 above.

Remove the main burner as described in section 9.4. Replace the burner in reverse order taking care that the locating pin in the rear of the burner locates with the slot in the rear frame and that the union joint ring is correctly positioned.

10.4 Piezo Spark Generator

Remove the front casing as described in section 9.1 above.

Pull forward the lower front of the casing to clear the tap spindles and lift up the casing to unhook it from the appliance back plate.

Unscrew the locking ring from the front of the Piezo unit and withdraw the unit backwards through the mounting plate. Pull off the two push on terminals and discard the old unit.

Fit the new unit in reverse order taking care to locate the unit on the small retaining peg. Also ensure that the earthing wire is sprung into the hole in the mounting frame.

10.5 Heat Exchanger

Remove the heat exchanger as described in section 9.2 above.

Remove the overheat thermostat and pilot air inlet collector and fit to the new heat exchanger. Ensure that two new 'O' ring seals are fitted to the inlet and outlet pipes. Re-assemble in reverse order taking care to locate the heat exchanger on the two support hooks formed in the appliance back plate.

10.6 Water Control Assembly

a) Remove the front casing as described in section 9.1 above.

b) Isolate the appliance from incoming cold water

supply at the inlet cock.

Open the taps to release any remaining water pressure and drain the appliance.

- c) Remove the water discharge pipe.
- d) Undo the union connection on the water isolating cock.
- e) Pull out the retaining clips at the inlet and outlet connections on the water control body, and spring out the copper inlet and outlet pipes from the control body. Take care not to damage the two 'O' ring seals.
- f) Pass a screwdriver through the hole in the centre of the lower edge of the fascia panel and slacken the first of the two retaining screws. The second retaining screw is located at 90 degrees on the right and is accessed from the side.
- g) With both screws slackened the water control assembly can be withdrawn downwards away from the gas valve body.
- h) Replace in reverse order.

10.7 Gas Valve

- a) Remove the burner as described in section 9.4 above
- b) Remove the water control assembly as described in 10.6 above.
- c) Undo the gas inlet union at the rear of the gas valve
- d) Access the two gas valve retaining screws from the left hand side and remove.
- e) Withdraw the gas valve, complete with slider controls, from the appliance.
- f) Remove the Piezo igniter.
- g) Remove the control fascia by taking out the four fixing screws and lifting clear complete with slider knob.
- h) Prise out the slider bar and remove the two screws retaining the control frame and lift clear.
- i) Assemble the Piezo igniter, slider bar, control fascia and pilot pipe to the new gas valve.
- j) Re-assemble the gas valve, burner and water control assembly in reverse order.

10.8 Final Inspection

Turn on the gas supply at the main gas service cock and check for gas soundness in accordance with the current edition of BS 6891 while the appliance is running.

Re-commission the appliance as described in section 8.

11 Spare Parts

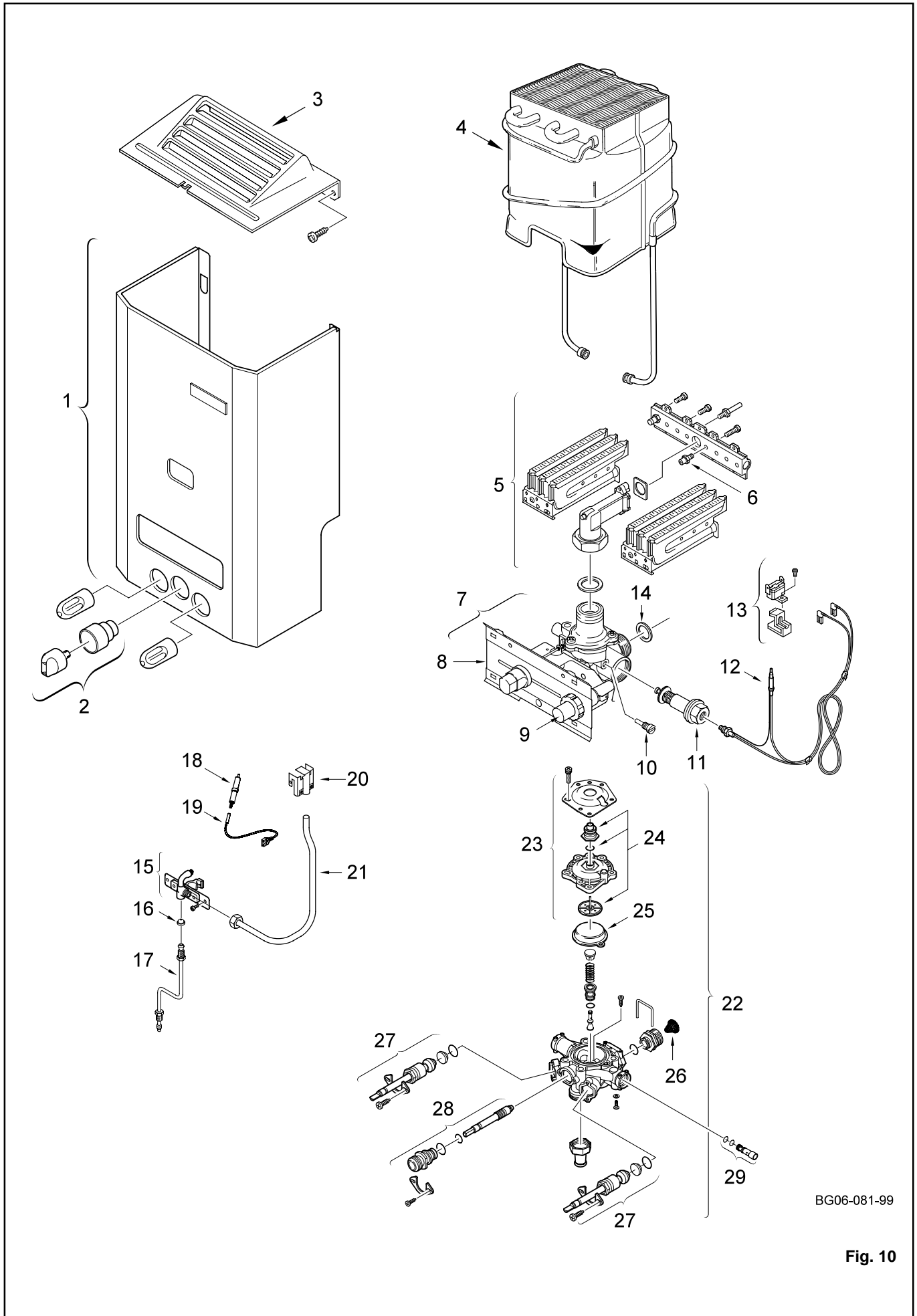

BG06-081-99

Fig. 10

Parts List

	Description	Propane	Natural Gas
1	Front Cover	8 705 411 730	
2	Temp. Control Knob	8 702 000 219	
3	Flue gas Deflector	8 705 505 249	
4	Heating Body	8 705 406 248	
5	Main Burner Assembly	8 708 120 239	8 708 120 352
6	Main Burner Injector	8 708 202 130	8 708 202 157
7	Gas Valve Assembly	8 707 011 786	8 707 011 100
8	Slide Assembly & Guide plate	8 701 000 105	
9	Piezo-Igniter	8 748 108 023	
10	Cross Ignition bolt	-----	8 703 407 027
11	Magnetic Unit	8 707 201 015	
12	Thermocouple	8 707 202 039	
13	Temperature Limit Thermostat	8 707 206 132	
14	Gas Inlet Washer	8 700 103 014	
15	Pilot Burner	8 708 105 327	8 708 105 320
16	Pilot Injector	8 708 200 138	8 748 200 120
17	Pilot Tube	8 700 707 334	
18	Spark Electrode	8 708 107 002	
19	Ignition Lead	8 704 401 022	
20	Pilot Air Collector	8 701 302 074	8 701 302 082
21	Pilot Air Inlet Pipe	8 700 705 527	
22	Water Valve Assembly	8 707 002 630	
23	Water Valve Cover	8 705 500 101	
24	Cover Repair Kit	8 700 306 098	
25	Diaphragm	8 700 503 050	
26	Water Strainer	8 700 507 001	
27	Valve spindle	8 708 500 277	
28	Selector Screw	8 708 500 233	
29	Venturi	8 708 205 275	

12 Fault Finding

Problem	Cause	Solution
Incorrect water temperature	Incorrect gas rate	Check the gas supply to appliance gas service cock Open the gas service cock Check the burner pressure Check the inlet pressure
	Water section sticking or faulty	Clean or replace
Incorrect water flow rate	Incoming supply valve closed	Open supply valve
	Low water pressure	Check if water pressure is above 0.15 bar
	Water section sticking or faulty	Clean or replace
Noise	Scale in heat exchanger	Descale and service
	High gas rate	Check the burner pressure
	Low water flow rate	Check the water flow rate
Pilot flame will not stay alight	No gas supply	Connect gas supply
	Gas service cock closed	Open gas service cock
	Air in gas line	Purge the line
	Pilot injector blocked	Clean or replace the injector
Main burner will not light	No spark	Clean or replace the electrode, piezo unit or cable
	Gas pressure low	Check the inlet and burner pressure
	Gas service cock partially closed	Open the gas service cock
	Low water rate	Check the water rate
	Water section diaphragm faulty	Replace the diaphragm
Buner extinguishes while in operation	Gas valve faulty	Replace the gas valve
	Oxygen deficiency sensor activated	Ventilate the room and re-ignite the appliance some minutes later. If it happens again, contact a Corgi registered technician.



Worcester Heat Systems Limited, Cotswold Way, Warndon, Worcester WR4 9SW.
Telephone: (01905) 754624. Fax: (01905) 754619

This booklet is accurate at the date of printing but will be superseded and should be disregarded if specifications and/or appearances are changed in the interests of continued improvement.

All goods sold are subject to our official Conditions of Sale, a copy of which may be obtained on application

6 720 606 003 (01.09) AL