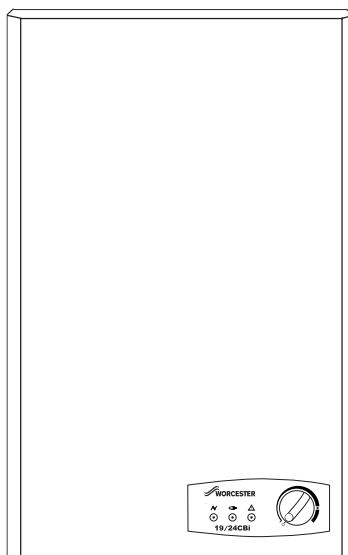


## 9/14CBi, 14/19CBi, 19/24CBi

WALL MOUNTED BOILERS FOR CENTRAL HEATING  
AND INDIRECT SUPPLY OF DOMESTIC HOT WATER

# INSTALLATION AND SERVICING INSTRUCTIONS



This appliance is for use with Natural Gas or LPG (Cat II 2H3P).

9/14CBi GC NUMBER 41 311 50 (N.G.)	9/14CBi GC NUMBER 41 311 51 (LPG)
14/19CBi GC NUMBER 41 311 52 (N.G.)	14/19CBi GC NUMBER 41 311 53 (LPG)
19/24CBi GC NUMBER 41 311 54 (N.G.)	19/24CBi GC NUMBER 41 311 55 (LPG)

### APPLIANCE OUTPUTS

9/14CBi N.G.  
Minimum 9.0 kW  
Maximum 14.0 kW

14/19CBi N.G.  
Minimum 14.0 kW  
Maximum 19.1 kW

19/24CBi N.G.  
Minimum 19.1 kW  
Maximum 23.5 kW

9/14CBi LPG  
Minimum 10.0 kW  
Maximum 14.0 kW

14/19CBi LPG  
Minimum 14.0 kW  
Maximum 19.1 kW

19/24CBi LPG  
Minimum 19.1 kW  
Maximum 23.5 kW

IMPORTANT: THESE INSTRUCTIONS APPLY IN THE UK ONLY  
AND MUST BE LEFT WITH THE USER OR AT THE GAS METER

Read the instructions before starting work - they have been written to make  
the installation easier and prevent hold-ups.

## Contents

1. Installation Regulations . . . . .	Page 2
2. Introduction . . . . .	Page 2
3. Technical Data . . . . .	Page 4
4. Siting the Appliance . . . . .	Page 6
5. Flue Terminal Positions . . . . .	Page 7
6. Air Supply . . . . .	Page 7
7. System. . . . .	Page 8
8. Domestic Hot Water . . . . .	Page 8
9. Gas Supply . . . . .	Page 10

## 1. Installation Regulations

### 1.1 Gas Safety (Installation & Use) Regulations 1998.

It is the law that all gas appliances are installed by a competent person in accordance with the above regulations. Failure to install appliances correctly could lead to prosecution. It is in your interest, and that of safety, to ensure compliance with the law.

1.2 The manufacturers notes must not be taken, in any way, as overriding statutory obligations.

1.3 The compliance with a British Standard or European Norm does not, in itself, confer immunity from legal obligations.

1.4 The installation of the appliance must be in accordance with the relevant requirements of the Gas Safety Regulations, current IEE Regulations, Building Regulations, Building Standards (Scotland) and local water bye-laws.

1.5 The installation should follow the recommendations of the following British Standards unless otherwise indicated and to any other relevant standards.

- BS5440:1 - Flues and ventilation for gas appliances: Flues
- BS5440:2 - Flues and ventilation for gas appliances: Air supply.
- BS5449 - Central heating for domestic premises.
- BS5546:1 - Installation of gas hot water supplies.
- BS5482 - Domestic Propane Gas Burning Installations.
- BS6700 - Domestic water supply (when relevant).
- BS6798 - Installation of gas fired hot water boilers.
- BS6891 - Low pressure gas pipework installations up to 28mm (R1).
- BS7593 - Water treatment.

1.6 The appliance and/or components must conform, where applicable, to all relevant Directives.

1.7 In accordance with COSSH the appliance does not contain any substances which are harmful to health.

1.8 Product Liability regulations indicate that, in certain circumstances, the installer can be held responsible, not only for mistakes on his part but also for damage resulting from the use of faulty materials. We advise that to avoid any risk, only quality approved branded fittings are used.

1.9 These instructions cover, as far as possible, the foreseeable situations which may arise. Contact The Worcester Technical Department, Telephone: 08705 266241, for advice on specific installations.

1.10 The appliance shall not be installed into a room or internal space below ground level when it is intended for use with LPG-propane (G31). This does not preclude the installation into a room or space which are basements with respect to one side of the building but are open to the ground on the opposite side.

10. Electrical. . . . .	Page 10
11. Installing the Appliance . . . . .	Page 15
12. Commissioning the Appliance . . . . .	Page 23
13. Instructions to the User . . . . .	Page 24
14. Inspection and Service. . . . .	Page 24
15. Replacement of Parts . . . . .	Page 26
16. Conversion Instructions. . . . .	Page 32
17. Component Parts List. . . . .	Page 33
18. Operational Flow Diagram . . . . .	Page 34
19. Fault Finding . . . . .	Page 35

## 2. Introduction

**(benchmark)** The Benchmark initiative is the new code of practice to encourage the correct installation, commissioning and servicing of domestic central heating boilers and system equipment. The 'checklist' is a vital document that must be completed by the installer at the time of installation and handed to the householder. It confirms that the boiler has been installed and commissioned according to the manufacturers instructions. Without the completion of the checklist, manufacturers may refuse to respond to a call-out from a householder, who will be advised that he or she must call back the installer, who has not fulfilled his obligations to record the information required by the initiative.

### 2.1 General Information

The Worcester boilers provide a heat output of between 9-14kW (9/14Cbi), 14-19kW (14/19Cbi) & 19-24kW (19/24 Cbi) factory set at mid-range and contain a temperature control and all the appropriate safety controls. They are suitable for fully pumped open vent or sealed systems.

They can be connected to a domestic hot water supply system through an external S or Y plan system.

### 2.2 Electrical Supply

230V - 50Hz. Load 125 watts. External fuse 5A to BS 1362, Internal fuse F1 - 4A.

IP Rating: IP 20.

### 2.3 Gas supply

The 19/24Cbi appliance requires a maximum of 2.72 m<sup>3</sup>/h of natural gas (G20), 1.05 m<sup>3</sup>/h propane (G31).

The 14/19Cbi appliance requires a maximum of 2.18 m<sup>3</sup>/h of natural gas (G20), 0.84 m<sup>3</sup>/h propane (G31).

The 9/14Cbi appliance requires a maximum of 1.62 m<sup>3</sup>/h of natural gas (G20), 0.63 m<sup>3</sup>/h propane (G31).

The installation and the connection of the gas supply to the appliance must be in accordance with BS6891 or BS5482 for LPG. The meter or regulator should deliver a dynamic pressure of 20 mbar for natural gas (G20) at the appliance, which is equivalent to about 19.0 mbar at the gas valve inlet pressure test point, or a dynamic pressure of 37 mbar for propane (G31) - equivalent to 36.0 mbar at gas valve inlet pressure test point.

### 2.4 Installation

The appliance is suitable for indoor installation only and for use with a fully pumped open vent or sealed system with an indirect cylinder. It is not suitable for use with a direct cylinder.

If the appliance is fitted in a cupboard or a compartment is built around it after installation, then the structure must conform with the requirements of BS6798. The spaces specified for servicing **must** be maintained. Refer to Section 6.

### 2.5 System

**(benchmark)** All dirt and system cleanser must be fully flushed from any system to be connected to the appliance. Refer to Fig. 5,6 and 7. A system by-pass maybe required dependent on the system which can take the form of a single uncontrolled radiator located at least 2m from the boiler - usually in the bathroom. See Section 7 for more details.

The connections in any system must withstand a pressure of up to 3 bar. Radiator valves must conform to BS2767:10.

### 2.6 Domestic Hot Water

Single feed direct cylinders are **NOT** suitable and must not be used. A HW cylinder must be of the indirect coil type and suitable for

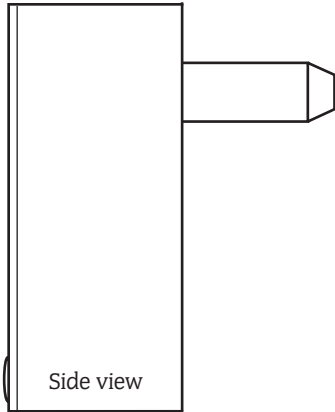
working at a gauge pressure of at least 0.35bar above the relief valve setting if on a sealed system.

Where a storage system will not have a vent to atmosphere the installation must comply with Building Regulations and Water Company bye-laws. If connecting to an existing system the local authority should be informed.

### 2.7 Flue

There are 3 fluing options available.

#### (i) Rear Only Flue Kit.

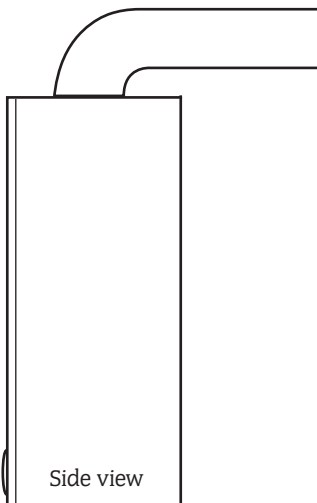


Flue can be fitted within the height of the casing from 220mm to 375mm without cutting.

The minimum length is 100mm with cutting.

No flue bends or extensions can be fitted to this system.

#### (ii) **Simplefit** Multi-Directional Horizontal Flue Kit.



**Simplefit** Standard Flue Kit can be adjusted from 425mm to 725mm without cutting. The minimum length is 250 mm with cutting.

Extended flue lengths upto a maximum of 2.5m (19/24CBi) and 3.0m (9/14 and 14/19CBi) are available.

Optional 45° and 90° flue bend kits are available **NOTE:** When using flue bends the maximum flue length is reduced (see Section 11.2.8).

If access to the flue is a problem then this option combined with an internal flue fixing kit should be used.

#### (iii) Vertical Flue Kit

A vertical flue option is also available with flue lengths from 1.1m (without cutting) to a maximum of 3.35m (19/24CBi) or 4.1m (9/14 and 14/19CBi). Optional 45° and 90° bends are available with this option. **NOTE:** When using flue bends the flue length is reduced (see Section 11.2.8).

### 2.8 Controls

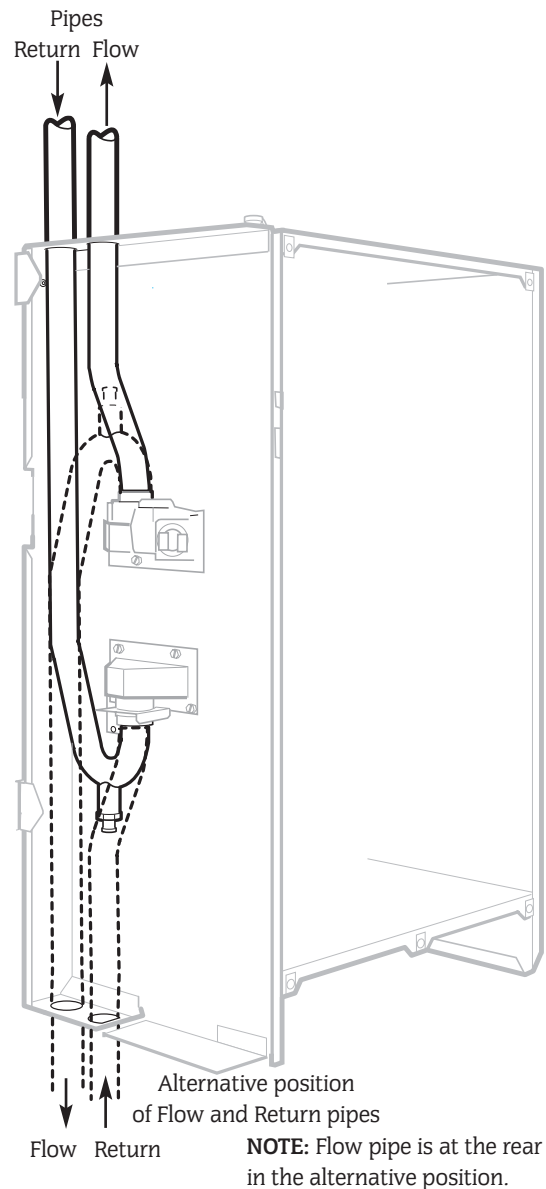
A control knob adjusts the boiler temperature, switches the boiler ON or to STANDBY and acts as a lock-out reset.

### 2.9 Safety

The appliance must not be operated with the inner casing cover removed. The gas and electricity supplies must be turned off before servicing or working on the appliance.

The casing is earthed through a push-on connector at the base. When the casing is refitted this connection **MUST** be remade.

**Fig. 1. Water flow diagram.**



**NOTE:** Flow pipe is at the rear in the alternative position.

### 2.10 Operation

#### Central Heating

A demand for heat will ignite the burner. The temperature is controlled by the integral sensor. At the end of the demand the burner will go out and the pump will continue to run for up to 4 minutes and the fan for 1 minute to dissipate the residual heat.

#### Domestic Hot Water:

The supply of domestic hot water depends upon the type of hot water equipment installed and the control system.

The use of unvented cylinders must be in accordance with the manufacturers instructions and relevant to British Standards.

The boiler is despatched from the factory with the flow and return pipework prepared for top outlet connection.

The pipework can be orientated to allow connection from the bottom by simply unplugging the bayonet style pushfit connections.

**NOTE:** When changing from a top connection to one at the bottom the pipe functions are reversed.

Top flow pipe becomes the bottom return pipe.

Top return pipe becomes the bottom flow pipe.

The drain off point on the return pipe becomes an air vent if the pipes are reversed. In this case a drain point should be fitted close to the appliance.

### 3. Technical Data


The data plate is fixed to the inner casing cover.

**Table 1.** Factory set at maximum input

NOMINAL BOILER RATINGS (10 Minutes After Lighting)				
APPLIANCE	OUTPUT	INPUT (Net)	BURNER PRESSURE	GAS RATE
	kW	kW	m bar.	m <sup>3</sup> /h
9/14CBi NG	14.00	15.28	11.0	1.62
	11.50	12.70	7.3	1.41
	9.00	10.11	4.5	1.07
14/19CBi NG	19.05	20.57	11.5	2.18
	16.52	17.96	8.5	1.90
	14.00	15.38	6.0	1.63
19/24CBi NG	23.45	25.74	12.0	2.72
	21.25	23.35	9.8	2.47
	19.05	21.16	7.8	2.24
9/14CBi LPG	14.00	15.28	27.2	0.63
	12.00	13.18	20.4	0.54
	10.00	11.17	15.4	0.45
14/19CBi LPG	19.05	20.57	25.4	0.84
	16.52	17.96	19.0	0.73
	14.00	15.38	13.9	0.63
19/24CBi LPG	23.45	25.74	29.9	1.05
	21.25	23.35	24.6	0.96
	19.05	21.16	20.2	0.87

Natural Gas: Net Input = Gross Input x 0.901  
Propane: Net Input = Gross Input x 0.921

**Table 2.**

FLUE DETAILS		
HORIZONTAL FLUE		mm
WALL HOLE DIAMETER	EXTERNAL FIX	110
	INTERNAL FIX	150
 STANDARD TELESCOPIC FLUE KIT	MINIMUM LENGTH	425
	MAXIMUM LENGTH	725
EXTENDED FLUE	MAXIMUM LENGTH	2.5m (19/24CBi) or 3.0m (9/14 and 14/19CBi)
INTERNAL FLUE - REAR ONLY WITHIN CABINET	MINIMUM LENGTH	220
	MAXIMUM LENGTH	375
FLUE ASSEMBLY DIAMETER		100
VERTICAL FLUE	MINIMUM LENGTH	1100
	MAXIMUM LENGTH INCLUDING TERMINAL	3.35m (19/24CBi) or 4.1m (9/14 and 14/19CBi)

**NOTE:** FOR VERTICAL FLUE REFER TO A SEPARATE LEAFLET FOR INFORMATION

**Table 3 9/14CBi**

HYDRAULIC RESISTANCE			
BOILER OUTPUT	RESISTANCE	MIN. FLOW RATE	FLOW/RETURN DIFFERENTIAL
kW	Metres	L/min.	°C
9.0	0.06	6.5	20
	0.13	11.7	11
14.0	0.28	18.2	11

**NOTE:** Pump is fitted externally

**Table 3 14/19CBi**

HYDRAULIC RESISTANCE			
BOILER OUTPUT	RESISTANCE	MIN. FLOW RATE	FLOW/RETURN DIFFERENTIAL
kW	Metres	L/min.	°C
14.0	0.09	10	20
	0.26	18.2	11
19.05	0.52	24.8	11

**Table 3 19/24CBi**

HYDRAULIC RESISTANCE			
BOILER OUTPUT	RESISTANCE	MIN. FLOW RATE	FLOW/RETURN DIFFERENTIAL
kW	Metres	L/min.	°C
19.05	0.15	13.7	20
	0.52	24.8	11
23.44	0.73	30.5	11

Table 4

MECHANICAL SPECIFICATIONS		
FLOW - COPPER TAILS	22mm	
RETURN - COPPER TAILS	22mm	
GAS INLET	15mm COMPRESSION	
CASING HEIGHT	600mm	
CASING WIDTH	390mm	
CASING DEPTH	260mm	
WEIGHT - LIFT	9/14CBi 28kg	14/19 & 19/24CBi 33.5kg
WEIGHT - PACKAGED	9/14CBi 41kg	14/19 & 19/24CBi 47kg

Table 5

PERFORMANCE SPECIFICATIONS			
PRIMARY WATER CAPACITY	9/14CBi 1.6 litres		14/19 & 19/24CBi 2.1 litres
STATIC HEAD	MINIMUM 1.2M		MAXIMUM 30M
MAXIMUM FLOW TEMPERATURE	82°C (nom)		
MAXIMUM CENTRAL HEATING SYSTEM OPERATING PRESSURE (Sealed System)	2.5 bar		
MINIMUM CENTRAL HEATING SYSTEM SET PRESSURE (Sealed System)	0.12 bar		
OUTPUT TO CENTRAL HEATING	9/14CBi 9.0 - 14.0kw	14/19CBi 14.0 - 19.05kw	19/24CBi 19.05 - 23.45kw
NO <sub>x</sub> CLASSIFICATION FOR CBi APPLIANCES	Class 1		
SEDBUK NUMBER AND BAND*	9/14CBi NG 78.5 D	14/19CBi NG 79.4 D	19/24CBi NG 78.4 D
	9/14CBi LPG 81.0 D	14/19CBi LPG 81.7 D	19/24CBi LPG 80.8 D

\* The value is used in the UK Government Standard Assessment Procedure (SAP) for the energy rating of dwellings. The test data from which it has been calculated have been certified by the GASTEC notified body.

Table 6

GAS SUPPLY SYSTEM - BASED ON NG (G20)				
TOTAL LENGTH OF GAS SUPPLY PIPE (COPPER) metres				
3	6	9	12	
MAXIMUM GAS DISCHARGE RATE - PRESSURE DROP 1mbar m <sup>3</sup> /h				PIPE DIAMETER mm
8.7	5.8	4.6	3.9	22
18.0	12.0	9.4	8.0	28

GAS SUPPLY SYSTEM - BASED ON PROPANE (G31)				
TOTAL LENGTH OF GAS SUPPLY PIPE (COPPER) metres				
3	6	9	12	PIPE DIAMETER mm
1.5	—	—	—	15
8.0	5.2	4.2	3.6	22
15.9	8.8	8.5	7.2	28

Table 7

CLEARANCES (mm)		
	INSTALLATION	SERVICE
ABOVE APPLIANCE - INTERNAL REAR FLUE	30	30
ABOVE APPLIANCE - EXTERNAL FLUE TURRET	180	180
IN FRONT OF APPLIANCE	600	600
BENEATH APPLIANCE	200	200
RIGHT HAND SIDE	5	5
LEFT HAND SIDE	5	5 * **

The appliance can be installed on the above clearance dimensions however, for improved access the following is suggested:

\* Improved access - 50mm is recommended

\*\* For improved access minimum clearance when fitted to an adjacent LHS wall is 100mm

NOTE: It is possible to fit the appliance in an unventilated compartment. Refer to Section 6 for details.

Table 8

SEALED SYSTEM CAPACITY - 10 litre vessel			
TOTAL SYSTEM VOLUME litres			
INITIAL PRESSURE bar	INITIAL CHARGE PRESSURE bar		
	0.5	1.0	1.5
1.0	72	92	N/A
1.5	39	53	64

## 4. Siting The Appliance

The appliance may be installed in any room subject to the requirements of the current IEE regulations and, in Scotland, the relevant electrical provisions of the Building Regulations with respect to the installation of appliances in rooms containing baths or showers.

If the appliance is installed in a room containing a bath or shower, any switch or appliance control using mains electricity must NOT be able to be touched by a person using the bath or shower.

The appliance shall not be installed in a room or internal space below ground level when it is intended for use with LPG propane (G31). This does not preclude the installation into a room or space which are basements with respect to one side of the building but are open to the ground on the opposite side.

The appliance is NOT suitable for external installation.

The wall must be able to support the weight of the appliance. Refer to Table 4.

The specified clearances must be available for installation and servicing. Refer to Table 7 and Fig.2.

The appliance can be installed in a cupboard/compartament to be used for airing clothes providing that the requirements of BS6798 and BS5440/2 are followed.

The clearance between the front of the appliance and the cupboard/compartament door should be not less than 25mm for air circulation.

Fig. 3. Appliance pipework connections

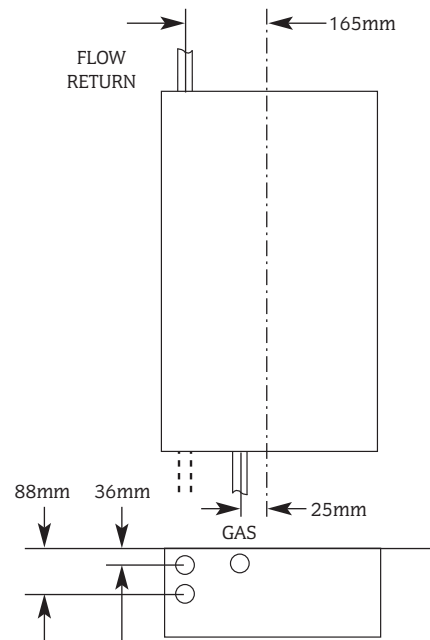
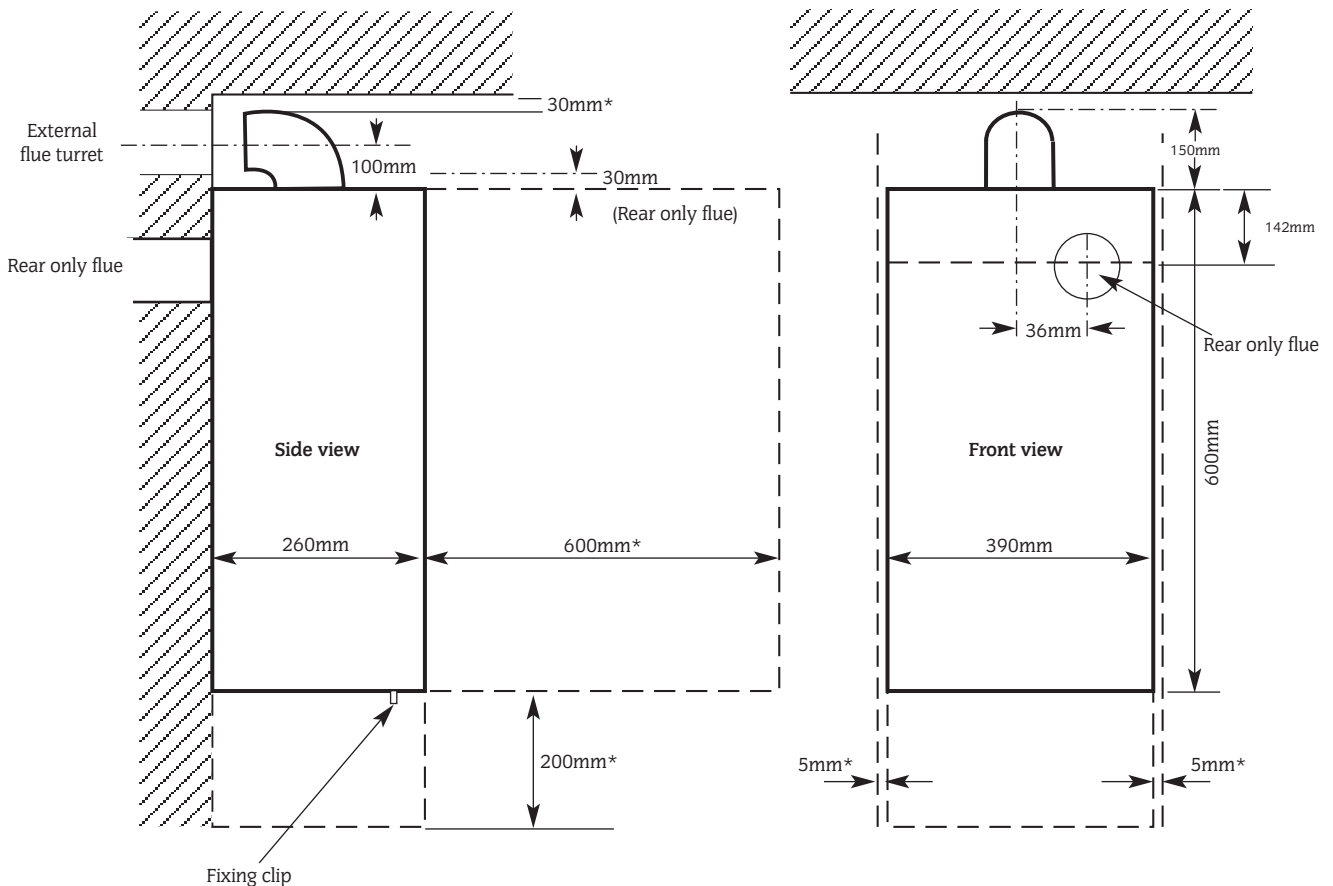


Fig. 2. Appliance casing dimensions and required clearances.



\* Space required for installation and servicing. Refer to Table 7

## 5. Flue terminal positions

The flue system must be installed following the requirements of BS5440:1.

The standard flue kit length is 425 - 725mm. Extension kits for flues up to 3.0m are available.

A rear flue suitable for walls from 220 - 375mm thick is available which can be contained within the boiler casing.

The terminal must not cause an obstruction nor the combustion products a nuisance.

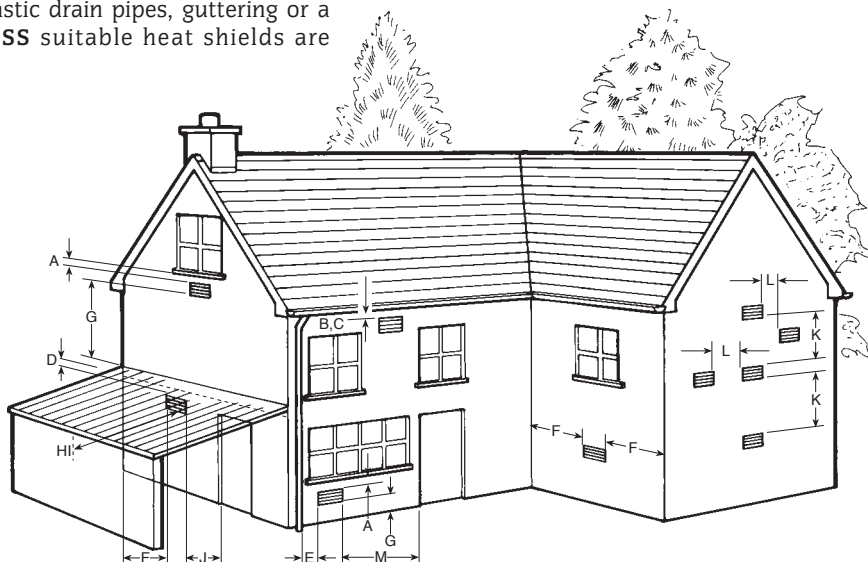
If the terminal is less than 2m above a surface to which people have access then a guard must be fitted. The guard must be evenly spaced about the terminal and fixed with plated screws.

A guard Type K2 can be obtained from Tower Flue Components, Vale Rise, Tonbridge, TN9 1TB.

It is essential that products of combustion cannot re-enter the building. Refer to Fig 4.

**Fig. 4. Siting of the flue terminal.**

**\*NOTE:** A minimum of 75mm must be achieved where the terminal is near fusible or combustible material such as plastic drain pipes, guttering or a carport roof **UNLESS** suitable heat shields are provided.



TERMINAL POSITION	MIN. DISTANCE	TERMINAL POSITION	MIN. DISTANCE
A- directly below an openable window or other opening e.g. air brick.	300mm	I- From a terminal facing a terminal	1200mm
B- Below gutters, soil pipes or drain pipes.*	75mm	J- From an opening in a car port (e.g. door window) into dwelling.	1200mm
C- Below eaves.*	25mm	K- Vertically from a terminal on the same wall.	1500mm
D- Below balconies or car port roof.*	25mm	L- Horizontally from a terminal on the same wall.	300mm
E- From vertical drain pipes and soil pipes.*	25mm	M- From door, window or air vent.	300mm
F- From internal or external corners.	25mm		
G- Above ground, roof or balcony level.	300mm		
H- From a surface facing a terminal.	600mm		

## 6. Air Supply

**A separate vent for combustion air is not required.**

The appliance can be fitted in a cupboard or compartment with no vents for cooling, but the minimum clearances must be increased to those given below. Refer to BS6798.

**Note:** the clearance at the front is to a removable panel, e.g. door. The user **must be** informed not to restrict the clearances by the addition of extra shelves etc and that flammable materials must not be stored in this compartment.

Above Appliance (when using Rear only Flue)	30mm
Above Appliance (when using <i>Simplefit</i> horizontal flue)	180mm
In front	340mm
Below	200mm
Right-hand side	105mm
Left-hand side	105mm

If the appliance is fitted in a cupboard or compartment with less clearance than those stated in the table above (minimum clearances are given in Section 4 Siting the Appliance) then permanent air vents for cooling are required, one at high level and one at low level. Both high and low level vents must communicate with the same room or must be on the same wall to outside air. The minimum requirements are:

Model	Position of vent	Air from room	Air from outside
19/24CBi	High	255cm <sup>2</sup>	128cm <sup>2</sup>
	Low	255cm <sup>2</sup>	128cm <sup>2</sup>
14/19CBi	High	207cm <sup>2</sup>	104cm <sup>2</sup>
	Low	207cm <sup>2</sup>	104cm <sup>2</sup>
9/14CBi	High	152cm <sup>2</sup>	76cm <sup>2</sup>
	Low	152cm <sup>2</sup>	76cm <sup>2</sup>

If the boiler is fitted between kitchen units and a decorative door panel is fitted then the top and bottom of the space must be left open.

## 7. System

The system must comply with requirements of BS6798 and BS5449.

### General:

The appliance is only suitable for connection to indirect fully pumped sealed and open vent systems. The minimum static head is 1.2m and the maximum is 30m.

The pump **MUST** be wired to the boiler control to ensure that the pump-overrun function operates to prevent the risk of overheating and hence nuisance shutdown.

The controls must be wired to ensure that the boiler does not cycle when electronically controlled zone valves are closed.

A by-pass is required if the controls i.e. 2-port valves, can result in the closure of the CH and DHW circuits when the boiler is hot.

If mechanically operated thermostatically controlled valves are fitted on all radiators then a by-pass located at least 2m from the boiler is required.

A bypass is generally unnecessary on a system using a 3 way diverter valve as one port will be open to flow at all times. This will be satisfactory for the pump overrun requirement. However if TRV's are used throughout then a bypass or open radiator may be necessary.

### Sealed System:

A sealed system must include an expansion vessel, pressure relief valve and pressure gauge - these are available as proprietary kits, the sealed system expansion vessel and fittings must be connected at the neutral point of the system on the entry to the pump. A pump and diverter valves are also required as appropriate to the system. Refer to Fig 5,6,7.

The sealed system must be filled through a WRc approved filling kit. Refer to Fig.8. The approved method for temporary connection for filling a closed circuit in a house can be found on Page 8.25. Fig R24-2a of the Water Regulation Guide and Water Bylaws 2000 Scotland.

The appliance must not be operated without the system being full of water and correctly pressurised.

All connections in the system must withstand a pressure of up to 3 bar.

The system and the appliance must be properly vented. Repeated venting loses water from the system and usually indicates that there is a leak.

## 8. Domestic Hot Water

The appliance is **NOT** suitable for direct water supply.

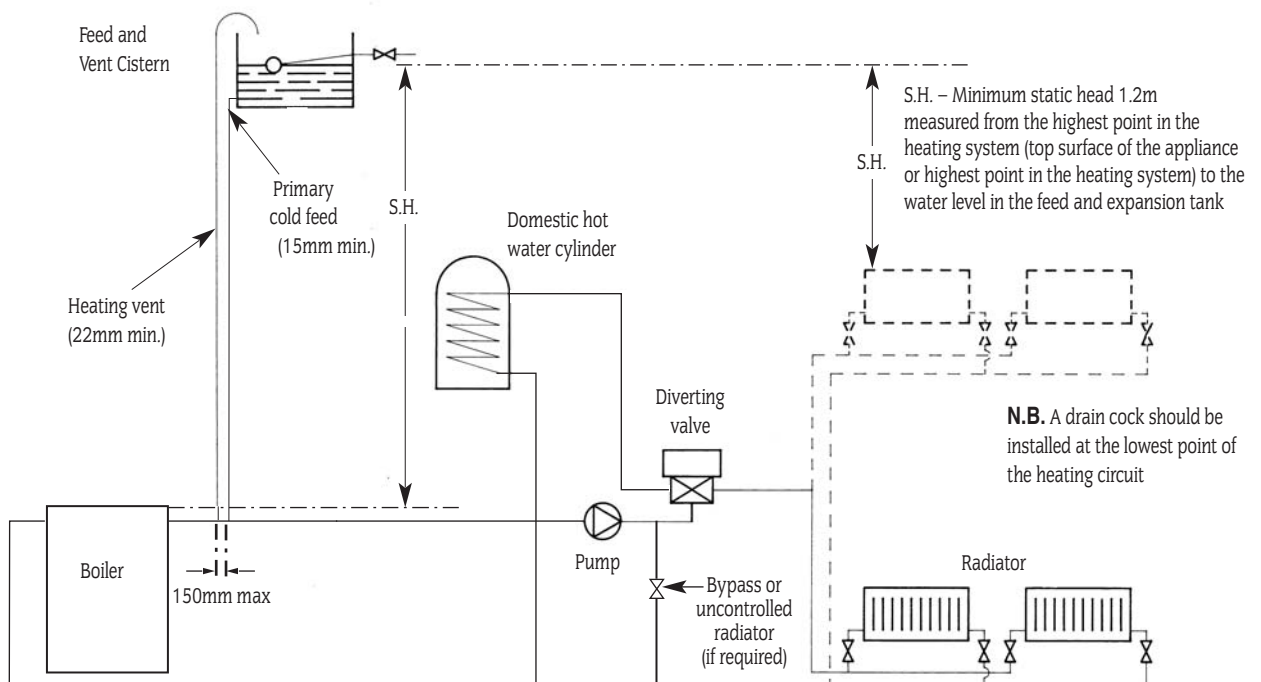
Do not connect to a direct cylinder.

The CBI can be connected to any indirect cylinder, i.e unvented or thermal store, and all the benefits of a "dry loft" and mains pressure hot water can be realised. Contact The Worcester Technical Helpline. 08705 266241.

### Cylinder

Indirect coil type or a direct cylinder with an immersion calorifier that is suitable for a pressure of 0.35bar above the setting of the pressure relief valve. Single feed indirect cylinders are **NOT** suitable for sealed systems. Any connection to the mains water supply must conform to the relevant Building and Water Regulations and be approved by the local Water company.

Fig. 5. System layout if using Honeywell 'Y' plan



For system wiring please refer to Fig. 10. and the controls manufacturers details.

Fig. 6. System layout if using Honeywell 'S' plan

For system wiring please refer to Fig. 10. and the controls manufacturers details.

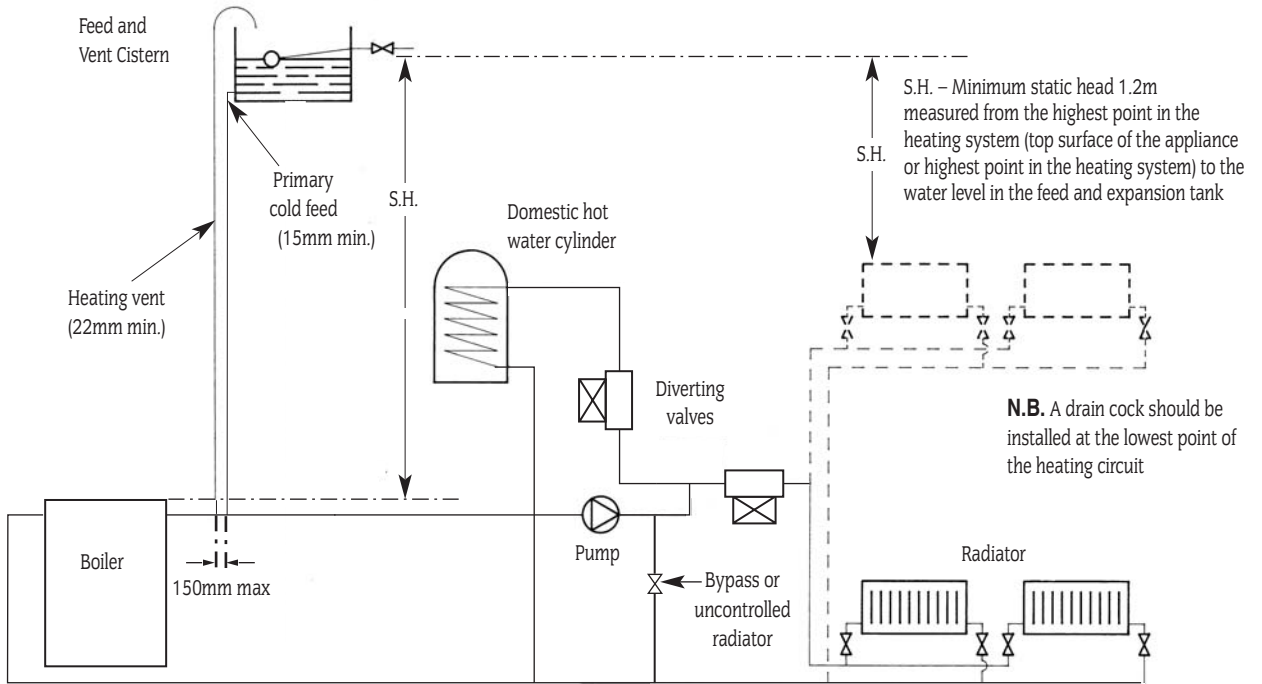
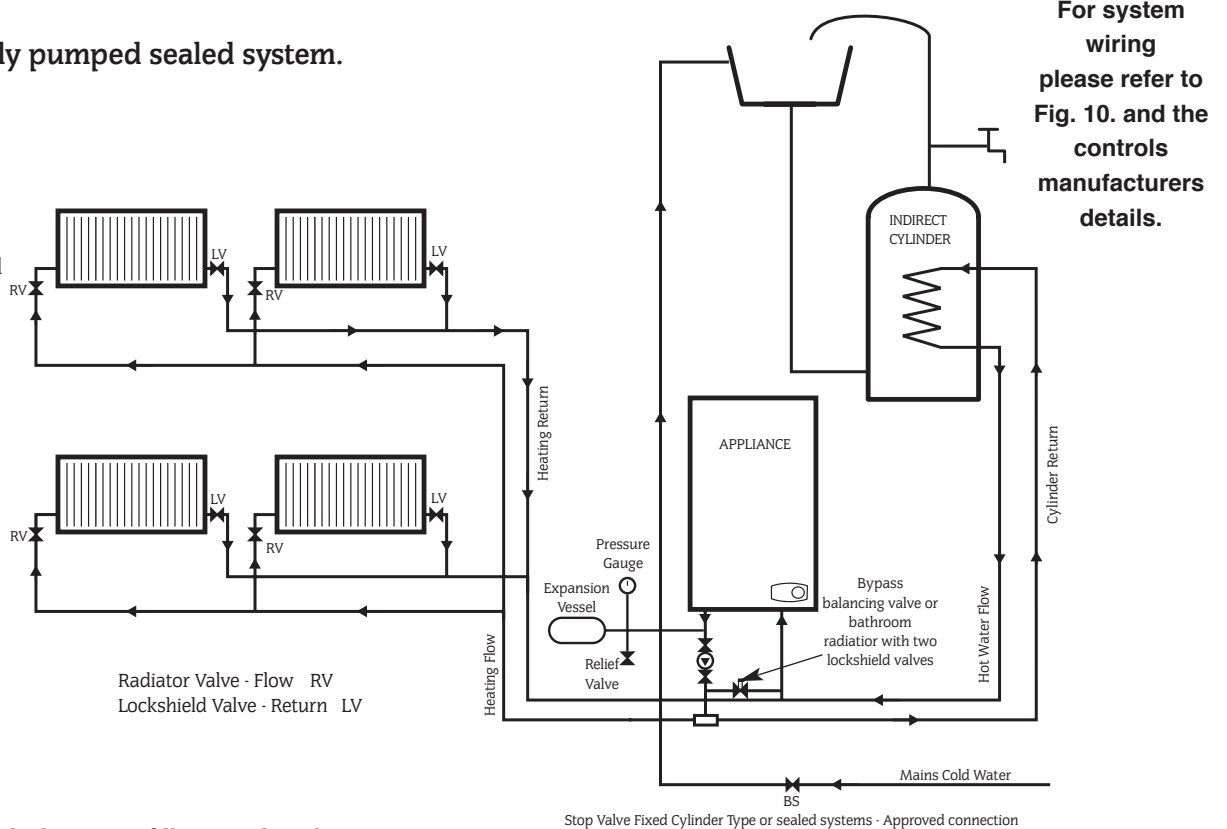


Fig. 7. Fully pumped sealed system.

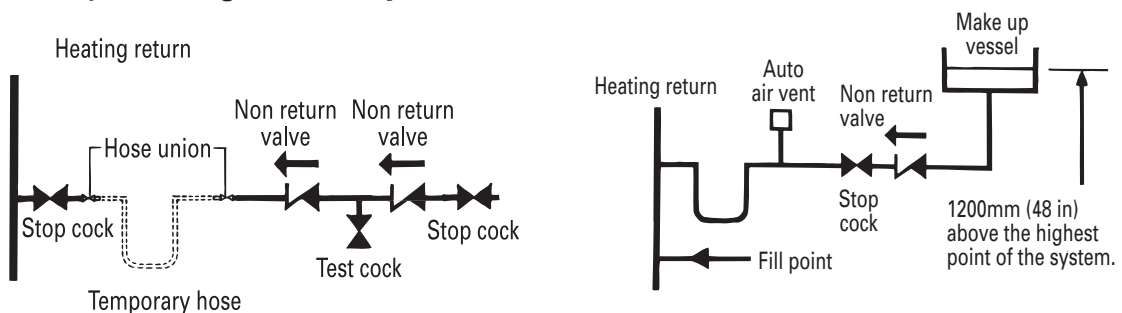
**Note:**

A drain cock should be fitted at the lowest point of the heating circuit and beneath the appliance



For system wiring please refer to Fig. 10. and the controls manufacturers details.

Fig. 8. Sealed system filling and make-up.



## 9. Gas Supply

The gas supplier must be contacted to check the suitability of the appliance for the local gas supply conditions before connecting the appliance.

The 19/24CBi appliance requires a maximum of 2.72 m<sup>3</sup>/h of natural gas (G20), 1.05 m<sup>3</sup>/h propane (G31).

The 14/19CBi appliance requires a maximum of 2.18 m<sup>3</sup>/h of natural gas (G20), 0.84 m<sup>3</sup>/h propane (G31).

The 9/14CBi appliance requires a maximum of 1.62 m<sup>3</sup>/h of natural gas (G20), 0.63 m<sup>3</sup>/h propane (G31). Refer to Table 1.

A natural gas appliance must be connected to a governed meter. The installation of the gas supply to the appliance must be in accordance with BS6891.

The meter and the pipework to the appliance must be checked, preferably by the gas supplier, to ensure that a dynamic pressure of 20mbar for natural gas is available at the appliance [equivalent to about 19.0 mbar at the gas valve inlet pressure connection] and that the gas flow is adequate for all the installed gas appliances or a dynamic pressure of 37 mbar equivalent to 36 mbar at gas valve inlet pressure connection on propane (G31).

## 10. Electrical

Mains Supply: 230V, 50 Hz, 125 watts.

External Fuse: 5A (must be to BS1362).

Internal Fuse: F1 4A (Spare supplied with appliance).

IP Rating: IP 20.

The appliance must be earthed and it must be possible to completely isolate the appliance.

The mains cable must be 0.75mm<sup>2</sup> (24 x 0.2mm) to BS6500 - Table 15 or 16

Mains supply to the boiler and system wiring centre must be through a common fused double pole isolator situated adjacent to the appliance. The isolator must have a contact separation of 3mm minimum in all poles. A single switched live cable should be wired into the boiler from the system wiring centre.

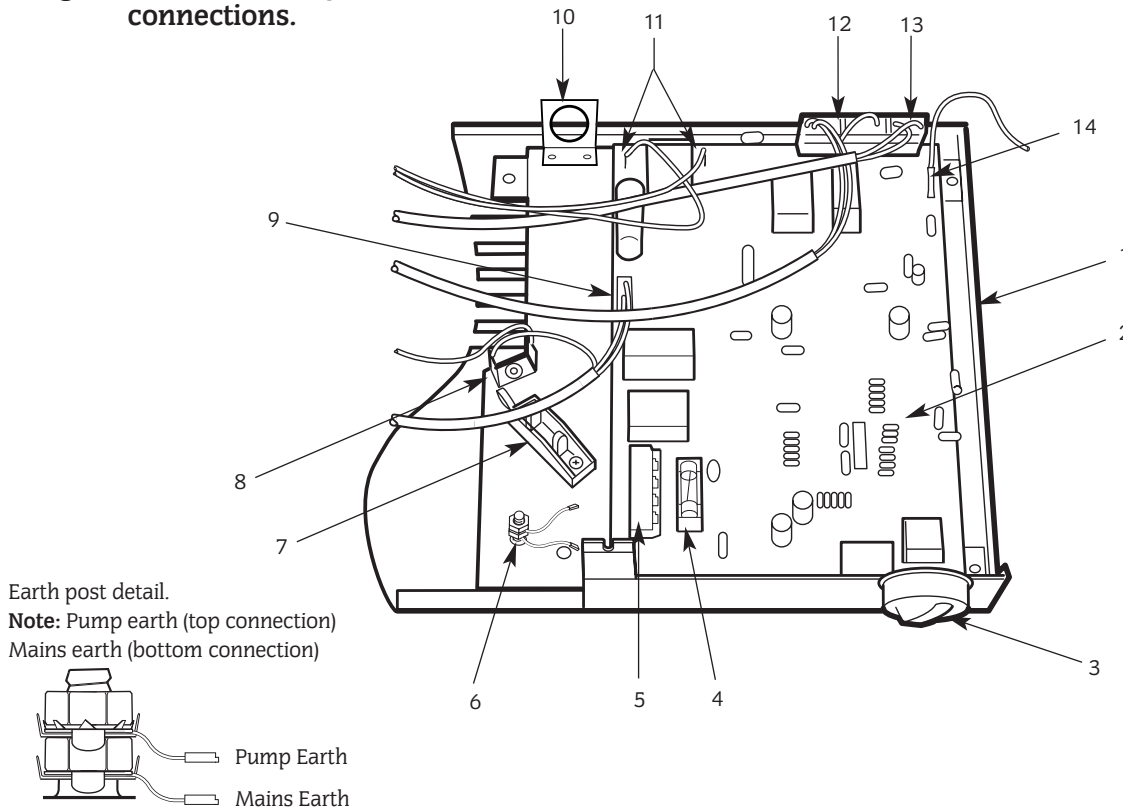
The mains and pump cables must be fed through the mains lead bracket, secured through the cable clamp and connected to the connector plug. Refer to Fig. 9, 10 and 11.

Frost protection of the boiler is provided on the control board.

A frost thermostat should be considered where parts of the system are remote from the appliance. For any frost thermostat function, the boiler temperature control knob must not be set to the 'OFF' position. The frost thermostat must be fitted to the system junction box in accordance with the manufacturers instructions. Refer to Fig. 11.

Safety Check: If there is an electrical fault after installation check for fuse failure, short circuits, incorrect polarity of connections, earth continuity or resistance to earth.

Fig.9 . Mains electricity and controls connections.



- |                                     |   |
|-------------------------------------|---|
| 1. Base plate                       | 9. Gas valve connection   |
| 2. Control board                    | 10. Mains lead bracket  |
| 3. Control knob                     | 11. Spark electrode connection  |
| 4. Fuse 4A                          | 12. Air pressure switch, temperature sensor, overheat thermostat connection |
| 5. External control connector block | 13. Fan connection  |
| 6. Earth post                       | 14. Flame sense connection  |
| 7. Cable clamp                      |   |
| 8. Internal earth connection        |   |

Fig.10. Boiler wiring diagram

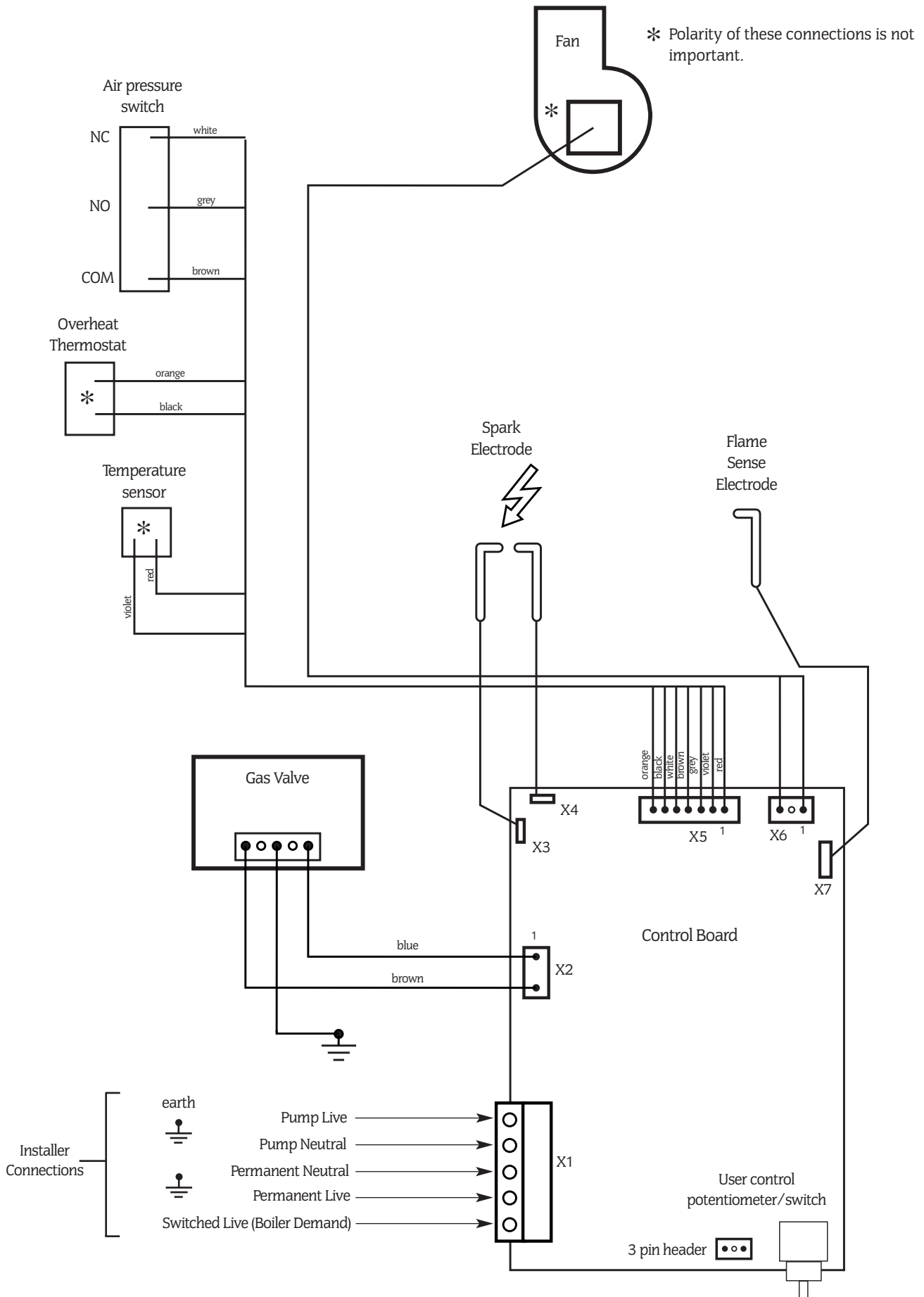
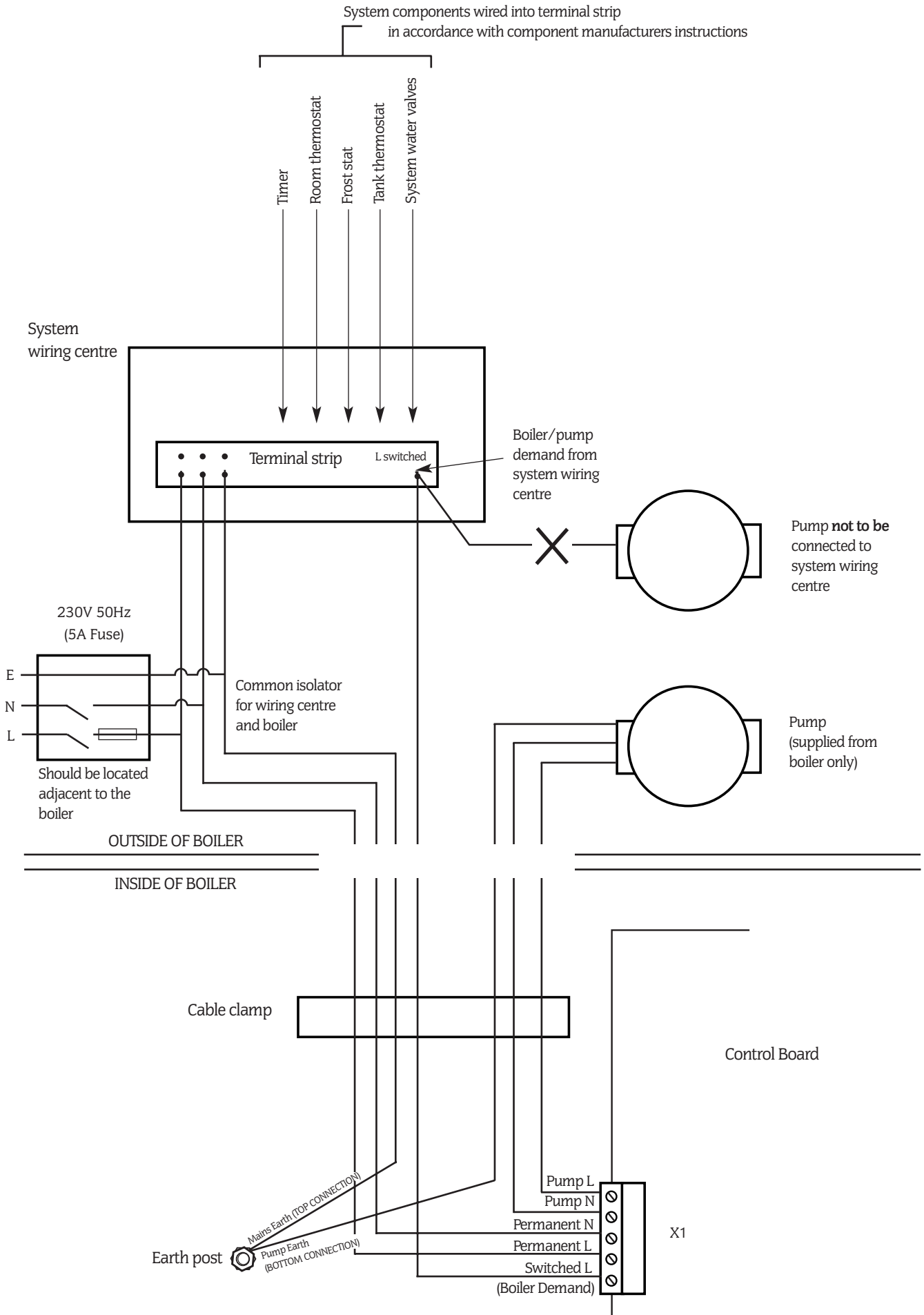
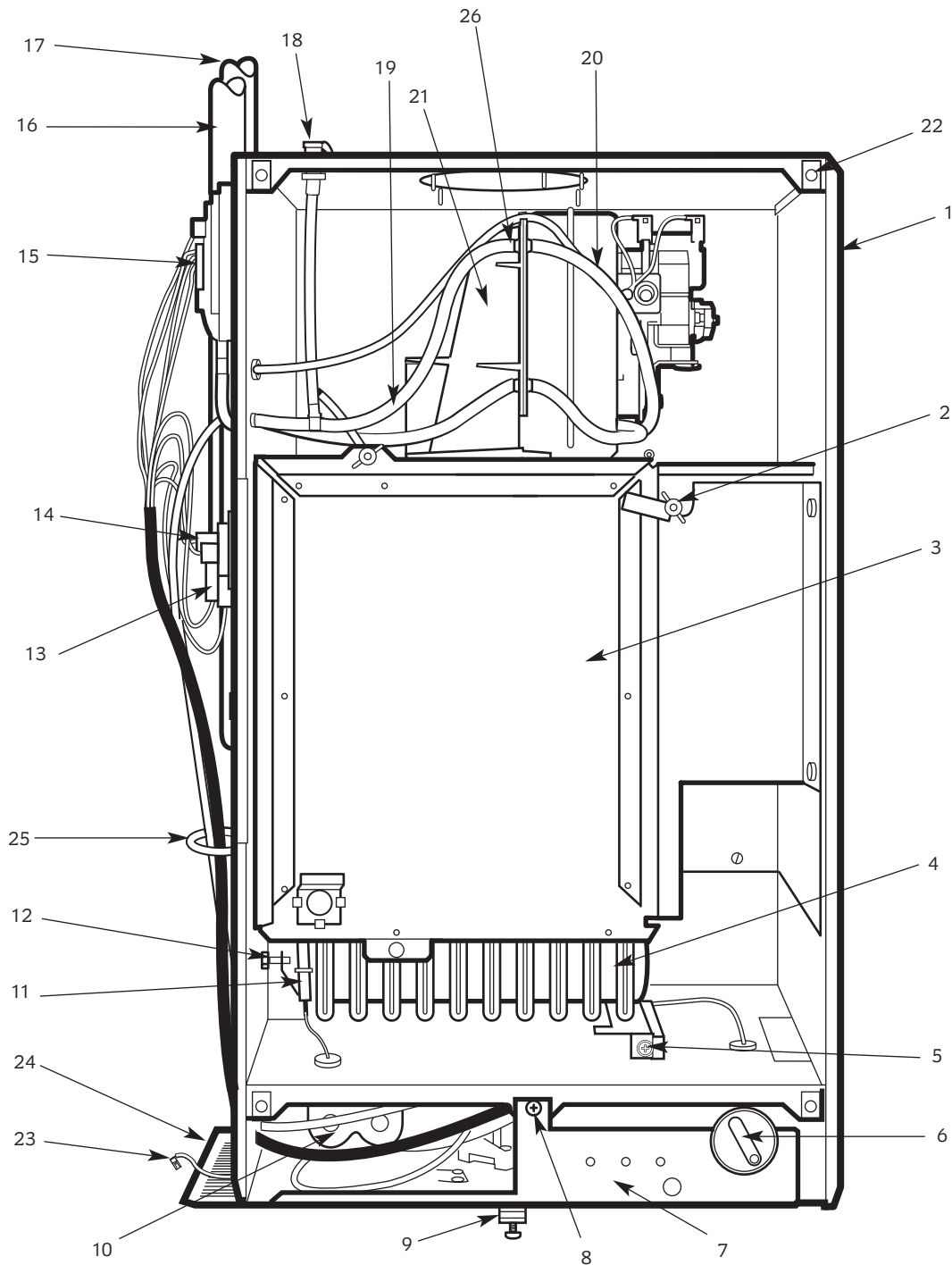


Fig.11 . System wiring diagram

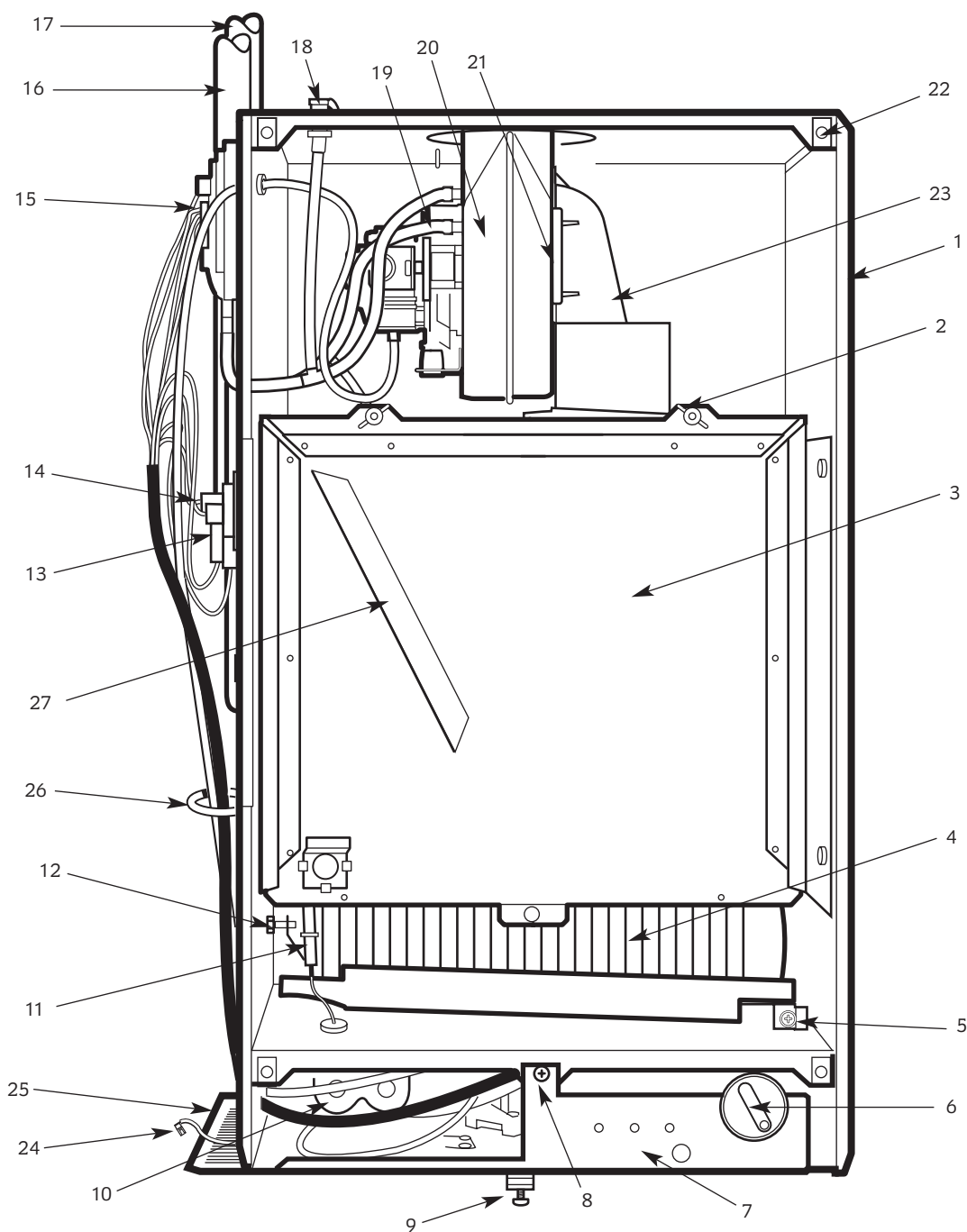


**Fig. 12a. Boiler Assembly 9/14CBI**  
**Shown set for Rear Only flue kit**



- |                               |  |
|-------------------------------|--|
| 1. Inner case                 | 14. Overheat thermostat                |
| 2. J bolts and wing nuts (2)  | 15. Air pressure switch                |
| 3. Combustion chamber cover   | 16. Flow pipe                          |
| 4. Burner                     | 17. Return pipe                        |
| 5. Burner fixing screw        | 18. Combustion test point              |
| 6. Control knob               | 19. Sensing tubes                      |
| 7. Indicator lights           | 20. Fan                                |
| 8. Base/controls fixing screw | 21. Flue hood                          |
| 9. Cabinet fixing screw       | 22. Inner case cover fixing points (4) |
| 10. Spark valve               | 23. Outer case earth tag               |
| 11. Spark electrode           | 24. Side cover plate                   |
| 12. Burner injector           | 25. Wire clip                          |
| 13. Temperature sensor        | 26. Pressure tube junction             |

**Fig. 12b. Boiler Assembly 14/19 and 19/24CBi**  
 Shown set for *Simplefit* horizontal flue or vertical flue



- |                               |  |
|-------------------------------|--|
| 1. Inner case                 | 15. Air pressure switch                |
| 2. J bolts and wing nuts (2)  | 16. Flow pipe                          |
| 3. Combustion chamber cover   | 17. Return pipe                        |
| 4. Burner                     | 18. Combustion test point              |
| 5. Burner fixing screw        | 19. Sensing tubes                      |
| 6. Control knob               | 20. Fan                                |
| 7. Indicator lights           | 21. Fan clamp (2 screws)               |
| 8. Base/controls fixing screw | 22. Inner case cover fixing points (4) |
| 9. Cabinet fixing screw       | 23. Flue hood                          |
| 10. Gas valve                 | 24. Outer case earth tag               |
| 11. Spark electrode           | 25. Side cover plate                   |
| 12. Burner injector           | 26. Wire clip                          |
| 13. Temperature sensor        | 27. Front baffle                       |
| 14. Overheat thermostat       |  |

# 11. Installing The Appliance

**NOTE:** READ THIS SECTION FULLY BEFORE COMMENCING THE INSTALLATION

To install a boiler with a rear only flue refer to Section 11.1.

To install a boiler with a *Simplefit* telescopic horizontal flue kit refer to Section 11.2.

To install a boiler with a vertical flue refer to Section 11.2. and the literature with the flue kit.

## 11. Installation of the Boiler with a Rear Only Flue Kit

### 11.1 Unpacking the Boiler

Check the contents against the packing list. Remove the wall mounting template, the mounting plate assembly and the external flue turret connector and restrictors.

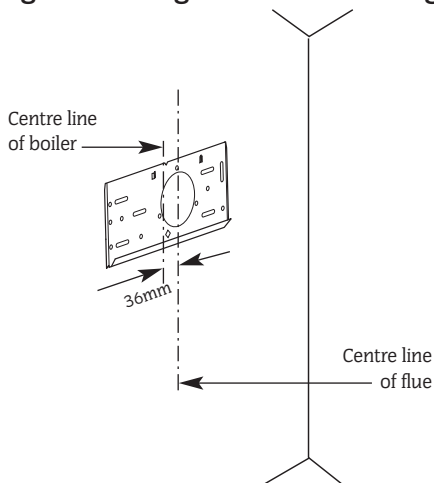
#### 11.1.2 Site Preparation

Check that the correct position for the appliance has been chosen and that the wall is sound, flat and will support the weight of the appliance. Refer to Sections 4 & 5 and Tables 4 to 8.

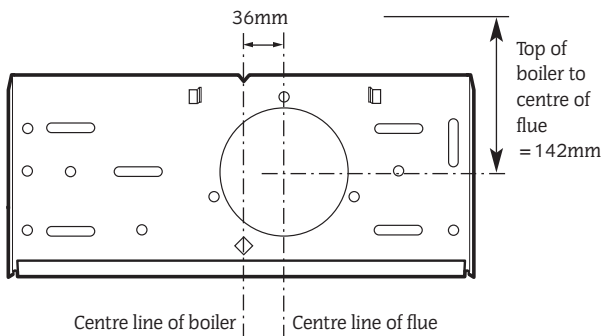
#### 11.1.3 Fixing Holes and Flue Opening

Hold the template to the wall. Check that the template is level. Mark the position of the fixing holes and the flue opening. Refer to Fig 13. Mark the position of the bottom fixing point for a screw or optional security bolt.

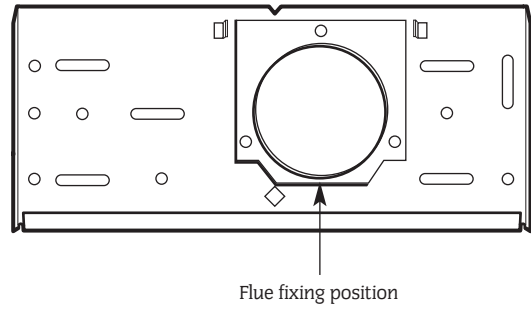
**Fig. 13 . Fixing the wall mounting plate.**



**Fig. 13a . Wall plate**



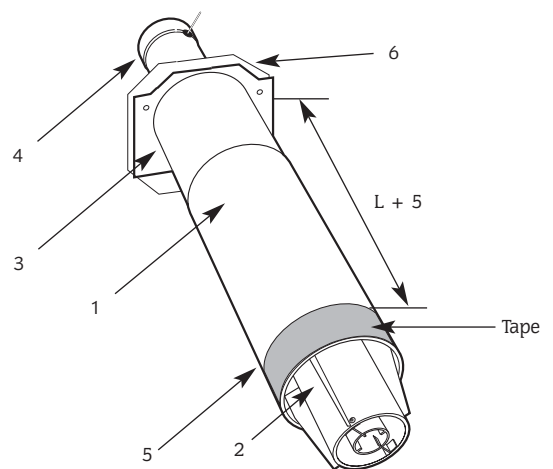
**Fig. 13b . Flue and wall plate**



### 11.1.4 Flue Preparation

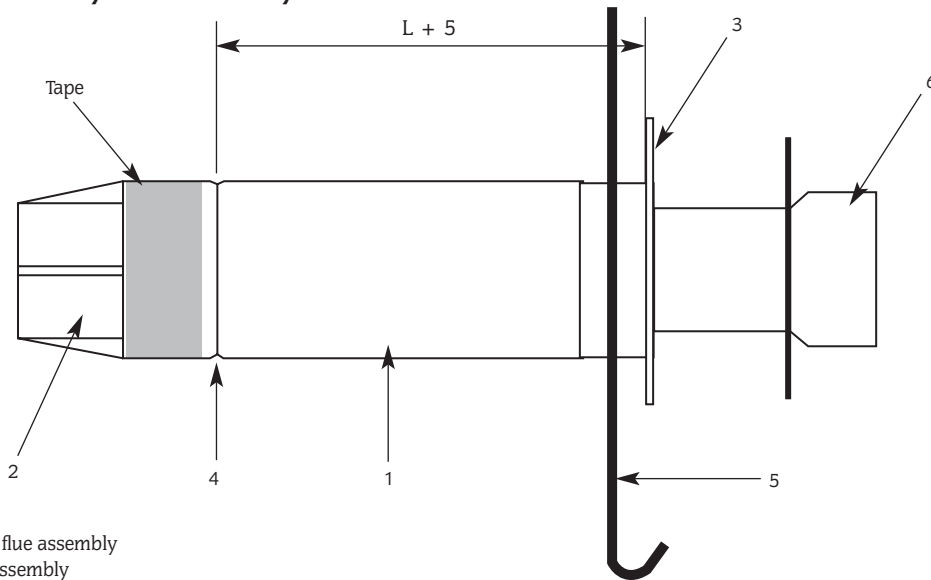
- (i) Drill the hole for the flue at 110mm diameter.
- (ii) Fix the wall-mounting plate - do not fully tighten the screws.
- (iii) Measure the wall thickness L - Min 220mm, Max 375mm. If L is less than 220mm thick then it is necessary to cut the flue. To do this subtract L from 220 and cut all flue parts by this amount. Ensure that the ducts are square and free from burrs. Always check dimensions before cutting. The minimum length L is 100mm with cutting.
- (iv) Adjust the telescopic flue assembly to a length L + 5mm and secure with the screw supplied. Refer to Fig. 14.
- (v) Apply the plastic tape onto the duct in contact with the wall (position shown in Fig. 14.).
- (vi) Remove the inner flue duct (with the fixing bar).
- (vii) Push the outer duct assembly through the wall mounting plate and wall. Tighten the wall mounting plate fixing screws after checking that the plate is level.

**Fig. 14 . Flue assembly - Rear Only Flue Kit**



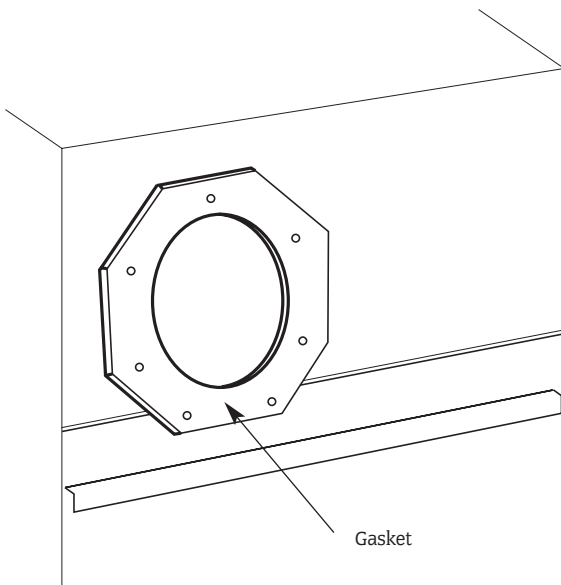
- |                             |                                  |
|-----------------------------|----------------------------------|
| 1. Telescopic flue assembly | 4. Flue tube with fixing bar     |
| 2. Terminal                 | 5. Indents                       |
| 3. Flange                   | 6. Gasket - fitted to inner case |

Fig. 14a . Rear only flue assembly



1. Telescopic flue assembly
2. Terminal assembly
3. Flange / flue assembly
4. Indents
5. Wall mounting plate
6. Flue tube with fixing bar

Fig. 14b . Rear of casing



### 11.1.5 Boiler Preparation

- (i) Remove the appliance casing by releasing the screw at the centre base. Disconnect the earth connection at the base and lift off.
- (ii) Release the four screws and remove the inner casing cover.
- (iii) Release the two wing-nuts and remove the combustion chamber front panel. The cover is located into notches at the base of the side plates. Leave the stainless steel baffles in place.
- (iv) Disconnect the fan electrical terminals and the sensing tube from the junction pieces. Slide the flue hood/fan assembly out of the boiler.
- (v) From the literature pack take the self adhesive gasket and stick around the rear flue opening on the outside of the casing ensuring that the fixing holes are not blocked (see Fig. 14b).

### 11.1.6 Install the Boiler



**IMPORTANT:** Thoroughly flush the system before connecting the boiler. Any system cleanser must be flushed from the system before adding any inhibitor.

- (i) Lift the boiler onto the wall mounting plate. See Fig. 15.
- (ii) Level the boiler using the two levelling feet at the base of the back panel.
- (iii) Fit the bottom fixing screw (or optional security screw).
- (iv) Connect the gas supply using the nut and olive supplied in the literature pack - details of the position are shown in Fig. 3.
- (v) Connect the flow and return pipes to the system. It is important that the flow and return pipes are not fixed near to the boiler using clips that put a strain on the connections.

A drain point should be fitted close to the appliance if bottom connections are made.

**Always consider the possible need to disconnect and remove the boiler.**

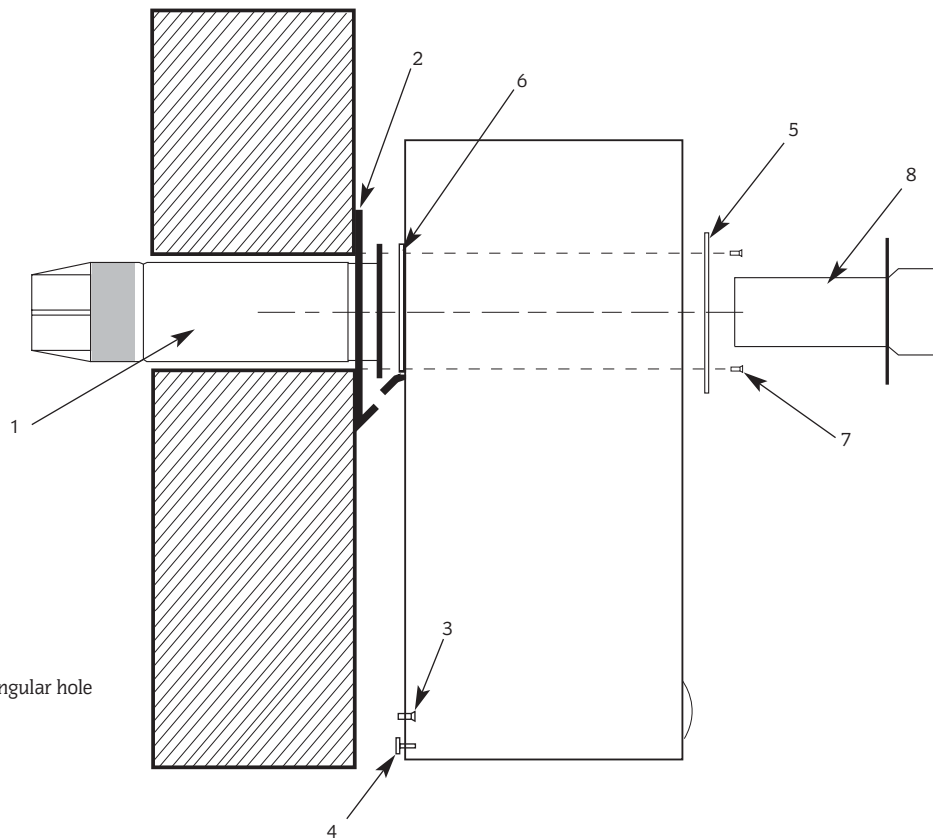
### 11.1.7 Installation of Flue onto Boiler

- (i) Pull the flue into position so that the holes in the flange line up with those in the case

**NOTE:** The correct rectangular flue restrictor must now be fitted when the boiler is on the wall.

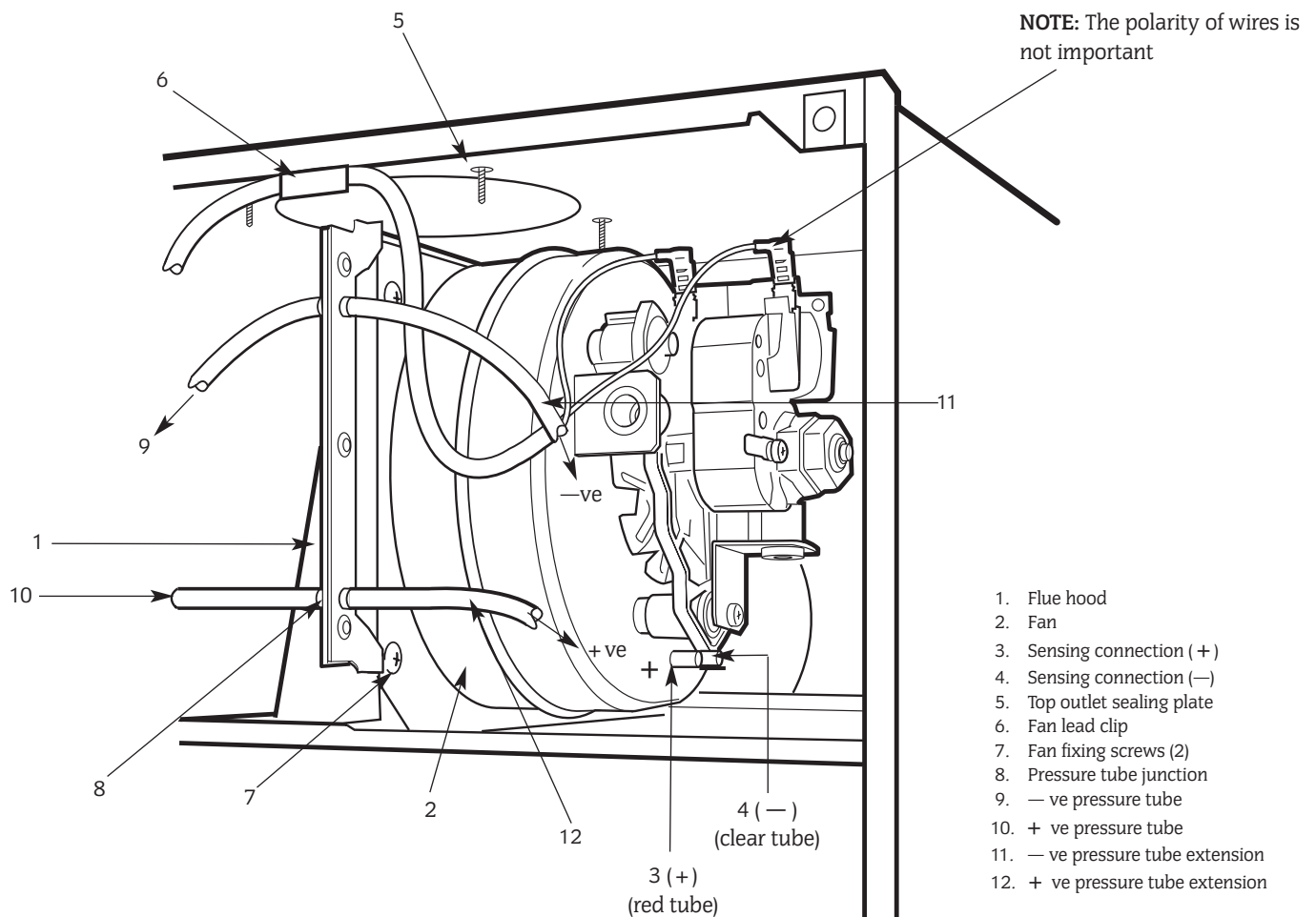
- |                       |                       |
|-----------------------|-----------------------|
| 9/14CBi and 14/19CBi  | 19/24CBi              |
| 66 X 62 (Rectangular) | 77 X 62 (Rectangular) |
- (ii) From the inside, place the correct restrictor in position over the flue opening and using the screws provided, fix through the inner casing into the flue system.
  - (iii) Slide the inner flue duct with fixing bar into the flue.
  - (iv) Slide the fluehood and fan assembly back into position engaging the fan outlet into the inner duct assembly and reconnect the fan electrical terminals (polarity is not important). Reconnect the pressure sensing tubes onto the junction pieces. See Fig. 16.
  - (v) Ensure that the combustion chamber is slotted underneath the flue hood and re-assemble with the combustion chamber front and 'J' bolts.

Fig. 15 . Fixing the appliance to the wall mounting plate.



- 1. Telescopic flue assembly
- 2. Wall mounting plate
- 3. Fixing or security screw
- 4. Levelling feet (2)
- 5. Restrictor plate with rectangular hole
- 6. Gasket
- 7. Flue fixing screws
- 8. Flue tube with fixing bar

Fig. 16 . Fan/Flue hood Assembly with Rear Only Flue Kit



NOTE: The polarity of wires is not important

- 1. Flue hood
- 2. Fan
- 3. Sensing connection (+)
- 4. Sensing connection (-)
- 5. Top outlet sealing plate
- 6. Fan lead clip
- 7. Fan fixing screws (2)
- 8. Pressure tube junction
- 9. - ve pressure tube
- 10. + ve pressure tube
- 11. - ve pressure tube extension
- 12. + ve pressure tube extension

### 11.1.8 Completion of the Installation

Check that all the gas and water connections have been tightened.

Lower the base plate/control panel. Refer to Fig. 17.

The permanent mains and switched live supply to the boiler must come from the system junction box. Refer to Fig.11. A 4 core cable is recommended.

Feed the 4 core cable and the pump cables through the bracket and secure in the cable clamp. Refer to Fig. 17.

Fit all the supply and pump wires to the 5 way plug before fitting the plug to the socket on the board. This will avoid stress to the board when using a screwdriver. Refer to Fig.11. for the connections.

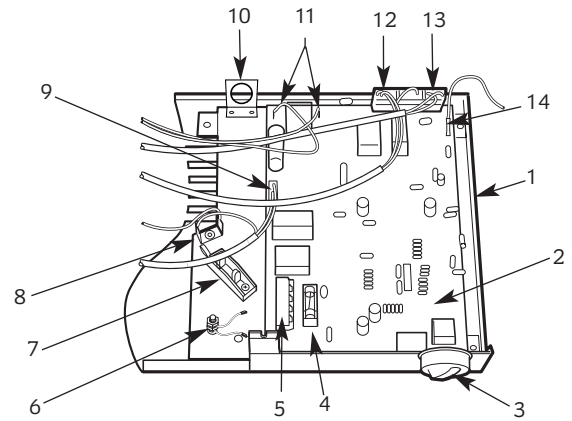
Check that the cables cannot touch the inner casing.

Test for gas soundness as described in BS6891.

If the appliance is not commissioned immediately, refit the combustion cover, inner casing cover, base/controls assembly and the casing. Re-connect the earth connection at the base of the casing. Check that the gas and electricity services have been turned off.

### REFER NOW TO SECTION 12 - COMMISSIONING THE APPLIANCE

**Fig.17 . Mains electricity and controls connections.**



- |                                     |                                |
|-------------------------------------|--------------------------------|
| 1. Base plate                       | 9. Gas valve connection        |
| 2. Control board                    | 10. Mains lead bracket         |
| 3. Control knob                     | 11. Spark electrode connection |
| 4. Fuse 4A                          | 12. Air pressure switch,       |
| 5. External control connector block | temperature sensor,            |
| 6. Earth post                       | overheat thermostat            |
| 7. Cable clamp                      | connection                     |
| 8. Internal earth connection        | 13. Fan connection             |
| 9. Gas valve connection             | 14. Flame sense connection     |

## 11.2 Installation of the Boiler with a *Simplefit* Telescopic Horizontal Flue Kit

### 11.2.1 Unpacking the Boiler

Check the contents against the packing list. Remove the wall mounting template, the mounting plate assembly and the flue spigot and restrictors. The flue spigot is positioned within the boiler carton and not in the accessory pack.

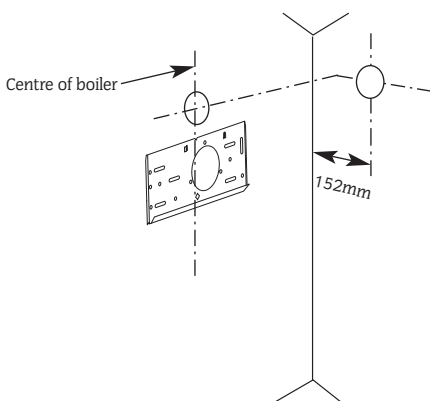
### 11.2.2 Site Preparation

Check that the correct position for the appliance has been chosen and that the wall is sound, flat and will support the weight of the appliance. Refer to Sections 4 & 5 and Tables 4 and 8.

### 11.2.3 Fixing Holes and Flue Opening

Hold the template to the wall. Check that the template is level. Mark the position of the fixing holes and the flue opening. Refer to Fig 13. Mark the position of the bottom fixing point for a screw or optional security bolt. Drill the 5 fixing holes 60mm deep for the No.12 size plugs.

**Fig. 18. Fixing the wall mounting plate.**



### 11.2.4 Boiler Preparation

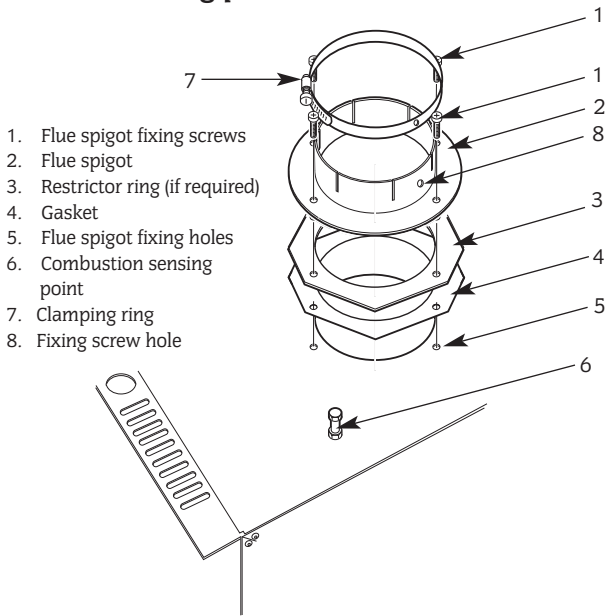
- (i) Remove the appliance casing by releasing the screw at the centre base. Disconnect the earth connection at the base and lift off.
- (ii) Release the four screws and remove the inner casing cover.
- (iii) Release the two wing-nuts and remove the combustion chamber front panel. The cover is located into notches at the base of the side plates. Leave the stainless steel baffles in place.
- (iv) Disconnect the fan electrical terminals and the sensing tube from the junction pieces. Slide the flue hood/fan assembly out of the boiler.
- (v) Remove the blanking plate from the top of the inner casing and refit onto the rear flue opening ensuring a good seal.
- (vi) From the literature pack take the self adhesive gasket and stick around the top flue opening on the outside of the casing ensuring that the fixing holes are not blocked (see Fig. 19).
- (vii) Fix the spigot and the appropriate restrictor (if the flue is less than 1m in length) to the top of the inner casing. Refer to Fig. 19. The fixing screw hole on the spigot must be pointing to the front.

IMPORTANT: Top Exit Restrictors	
9/14CBi and 14/19CBi	19/24CBi
Ø72mm	Ø79mm

- (viii) The boiler is supplied for flow and return connections at the top. If a bottom connection is required then pull out the clips, remove and invert the pipes. Refer to Fig. 1.
- NOTE:** When changing the connections the pipe functions are reversed -

Top flow becomes the bottom return  
Top return becomes bottom flow

**Fig.19. Flue turret fixing and combustion sensing point**



**11.2.5 Flue Preparation**

- (i) Drill the hole for the flue at Ø110mm unless the optional internal fitting kit (WHS part No. 7 716 191 019) is used in which case a Ø150mm hole is required.
- (ii) Fix the wall mounting plate onto the wall. Ensure it is level before tightening the screws.

(iii) The method of installation of the flue system may be varied to suit the actual site conditions. The instructions for connecting and fixing the ducts must, however, be strictly followed.

Remove all packing material from the flue components.

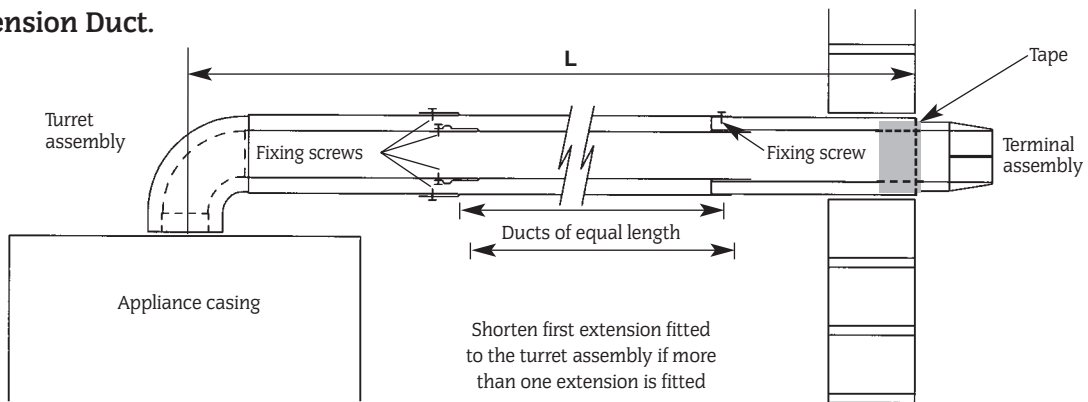
The standard telescopic flue assembly is suitable for lengths from 425mm up to 725mm measured from the centre-line of the boiler flue outlet to the outer face of the wall. Refer to Fig. 17.

If the length needed is greater than 725mm then extension duct kit/s will be required - each kit extends the flue by 750mm up to a maximum of 2.5m (19/24CBi) or 3.0m (9/14 and 14/19CBi). See table below.

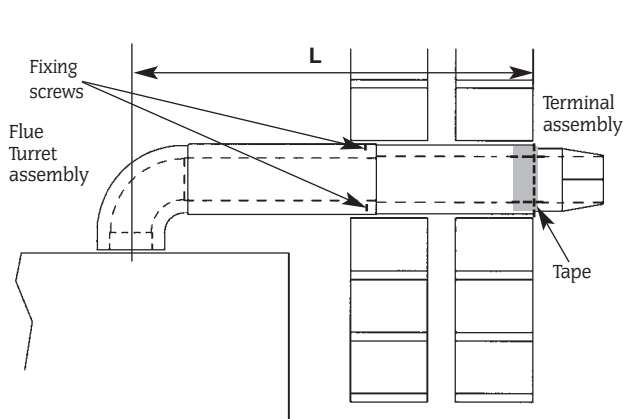
EXTENSION	MAXIMUM FLUE LENGTH mm
1	1475
2	2225
3	2500 (19/24CBi)
3	2975 (9/14 and 14/19CBi)

- (iv) Measure length L. Refer to Fig 20, 21, 22.
- (v) For installation of standard flue up to 750mm refer to Section 11.2.6.  
For installation of flue greater than 750mm refer to Section 11.2.7.  
For installation of bend kits refer to Sections above and Section 11.2.8.  
For installation of vertical adaptor refer to Section 11.2.9.  
For installation of internal fitting kit refer to Sections above and Section 11.2.10.

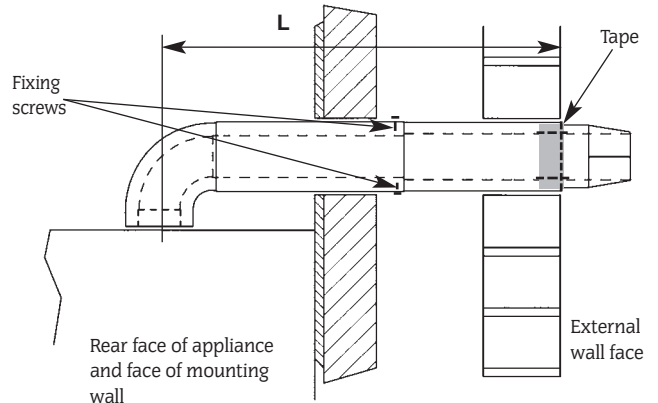
**Fig.20 . Extension Duct.**



**Fig.21. Flue duct length (side flue).**



**Fig.22 . Flue duct length (rear flue).**



### 11.2.6 *Simplefit* Telescopic Horizontal Flue Kit up to 750mm in Length

- (i) The standard flue can be telescopically adjusted to any length between 425mm and 725mm. It will only be necessary to cut the standard assembly if  $L < 425\text{mm}$ . Cut the flue turret assembly and the terminal assembly by the same amount i.e  $L = 350$  - remove 75mm from each assembly. The minimum length L is 250mm with cutting.

**General:** Cut the ducts as necessary, ensuring that the ducts are square and free from burrs. Always check the dimensions before cutting.

- (i) Fix the flue assembly together using the self-tapping screws provided. Refer to Fig. 21, 22.
- (ii) Apply the plastic tape onto the duct in contact with the wall (see Fig. 21, 22).

If an internal fitting kit is to be used refer now to Section 11.2.10 otherwise refer to Section 11.2.11.

### 11.2.7 *Simplefit* Telescopic Horizontal flue Kit Greater Than 750mm in Length

If bends are to be used refer also to Section 11.2.8.

- (i) By adding extension duct kits to the standard flue kit it is not necessary to cut the extension ducts if

L is between

1175 - 1475mm (1 extension)

1925 - 2225mm (2 extension)

- (ii) However extension ducts need to be cut if

L is between

725 - 1175mm (1 extension)

1475 - 1925mm (2 extension)

2225 - 2500mm (3 extension) 19/24 CBi

2225 - 2975mm (3 extension) 14/19 and 19/24CBi

- (iii) To shorten the duct the first extension only should be cut.

To work out the length to be cut off:

$(\text{No. of extensions} \times 750) + 425 - L = \text{length to be cut.}$

**NOTE:** Extension duct measurements do not include the socketed end. Unless specifically instructed the socketed end must not be removed.

- (iv) Fix the flue assembly together using the self tapping screws provided (see Fig. 20).

- (v) Apply the plastic tape onto the duct in contact with the wall (see Fig. 20).

If an internal fitting kit is to be used refer now to Section 11.2.10 otherwise refer to Section 11.2.11.

### 11.2.8 Flue Bends

90° and 45° directional bends are available. A maximum of two 45° or 90° bends may be used in addition to the first bend on the flue turret.

A 90° bend is equivalent to 750mm of straight duct.

A 45° bend is equivalent to 375mm of straight duct.

Measure the lengths X and Y. Refer to Fig.23.

The maximum value of X using the turret assembly only is 506mm. Reduce the ducts to the appropriate length e.g.  $X = 406\text{mm}$ , cut 100mm from the air duct and 120mm (to cover the entry into the 45° or 90° elbow) from the flue duct. Refer to Fig.24.

The final section, dimension Y, of the flue system must include a section of plain duct assembly i.e. an extension assembly with the sockets removed. Reduce the final section, including the terminal assembly, by the appropriate amount i.e. Air duct Y - 81mm and the flue duct Y - 51mm. Refer to Fig.23.

If Y is smaller than 425mm it will be necessary to cut the air and flue ducts of the extension to a plain length of 100mm and reduce the length of the terminal assembly e.g.  $Y = 350\text{mm}$  - remove 75mm from the terminal assembly.

If Y is between 425 and 725mm it is not necessary to cut the terminal assembly or use a second extension duct as the length can be set telescopically.

If Y is greater than 725mm then two extension duct assemblies will be required, the first assembly being cut to length as plain tubes.

If more than two extension ducts are needed in any section to achieve the required length then the final section of the assembly must not be less than 325mm without cutting the terminal assembly.

**NOTE:** The flue duct of the final extension must be 30mm longer than the air duct.

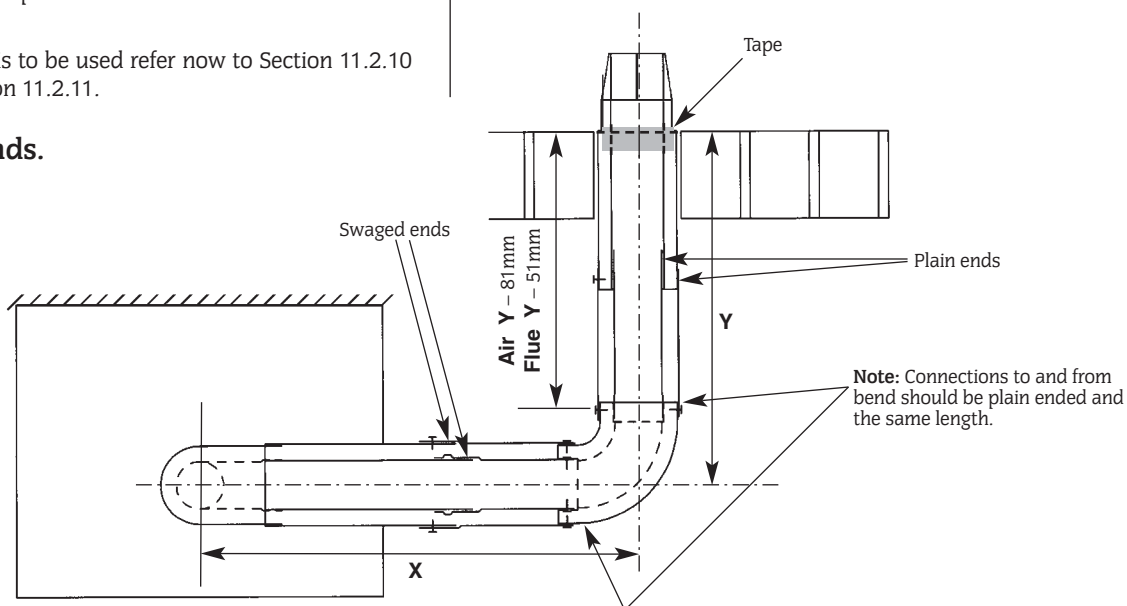
Each section must be connected to the previous section of the flue bend by fixing the flue ducts together and then similarly fixing the air ducts which engage the elbows.

Fix the flue assembly together using the self tapping screws provided.

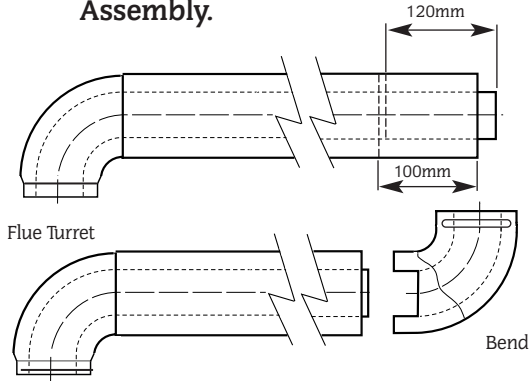
Apply the plastic tape onto the duct in contact with the wall (see Fig. 23).

If an internal fitting kit is to be used refer now to Section 11.2.10 otherwise refer to Section 11.2.11.

Fig. 23. Flue bends.



**Fig. 24 - Elbow to Flue Turret Assembly.**



**11.2.9 Vertical Adaptor for Horizontal Flues**

An adaptor is available for an initial short section of vertical flue. Refer to Fig. 25.

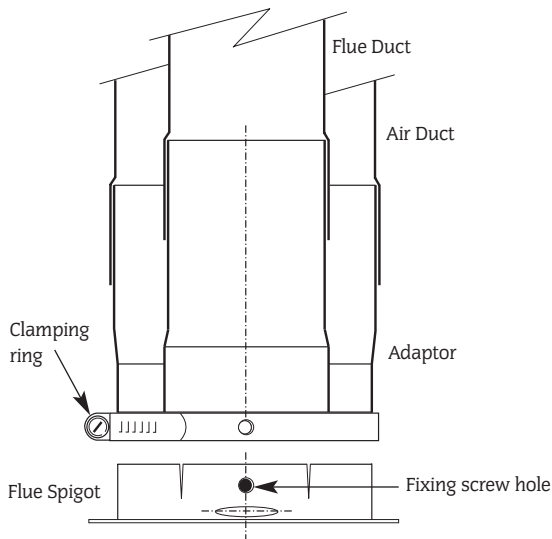
Measure and cut the flue as described in Section 11.2.7.

The first, vertical, section (equivalent to dimension X) is measured from the top of the boiler casing. Cut the vertical section of the extension duct to 167mm less than the measured distance. Do not remove the socketed ends.

The minimum measured distance is 167mm.

Seal the air duct to the turret using silicone sealant.

**Fig.25 Vertical Adaptor**



**11.2.10 Fitting of the Flue Assembly without access to the Terminal**

An internal flue fixing kit (WHS part No. 7 716 191 019) is available from Worcester, Bosch Group.

NOTE: A larger diameter opening (Ø150mm) in the wall is required. Refer to Table 2.

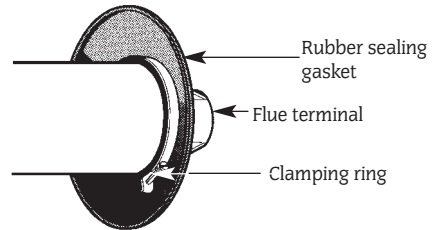
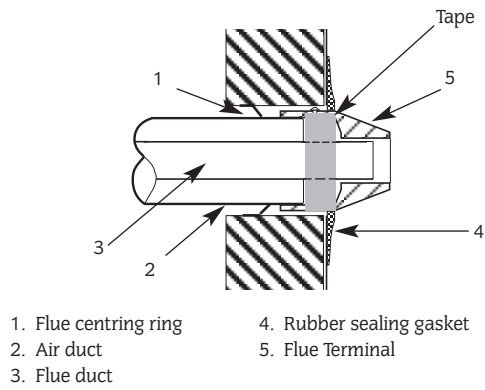
Prepare the flue assembly as described in Section 11.2.6 - 11.2.8.

Fit the rubber sealing gasket centrally onto the terminal assembly and tighten the clamp. Refer to Fig. 26.

Apply the plastic tape to the air duct in contact with the external brickwork.

From inside push the assembly through the wall so that the gasket flange is against the outer face. Refer to Fig. 26. It may be necessary to adjust the legs of the flue centring ring.

**Fig.26 . Terminal assembly for internal fitting of the flue.**



**11.2.11 Install the Boiler**



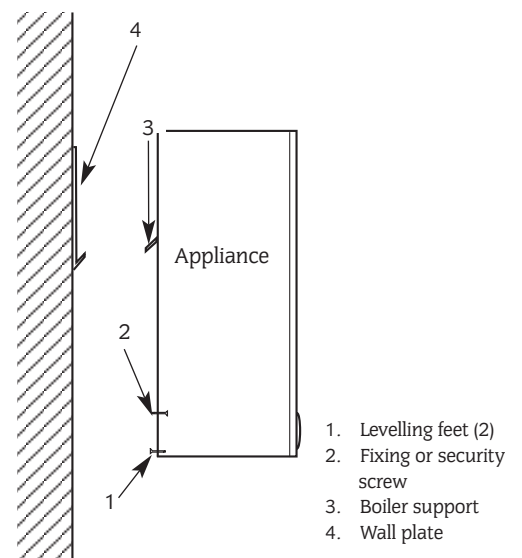
**IMPORTANT:** Thoroughly flush the system before connecting the boiler. Any system cleanser must be fully flushed from the system before adding any inhibitor.

- (i) Lift the boiler onto the wall mounting plate. See Fig. 27.
- (ii) Level the boiler using the two levelling feet at the base of the back panel.
- (iii) Fit the bottom fixing screw (or optional security screw).
- (iv) Connect the gas supply using the nut and olive supplied in the literature pack - details of the position are shown in Fig. 3.
- (v) Connect the flow and return pipes to the system. It is important that the flow and return pipes are not fixed near to the boiler using clips that put a strain on the connections.

A drain point should be fitted close to the appliance if bottom connections are made.

**Always consider the possible need to disconnect and remove the boiler.**

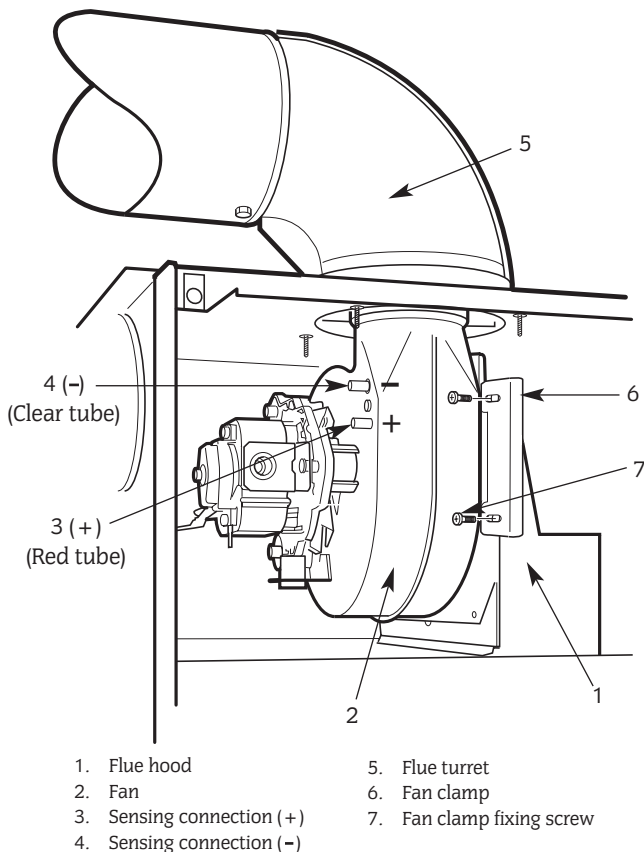
**Fig. 27 . Fixing the appliance to the wall mounting plate.**



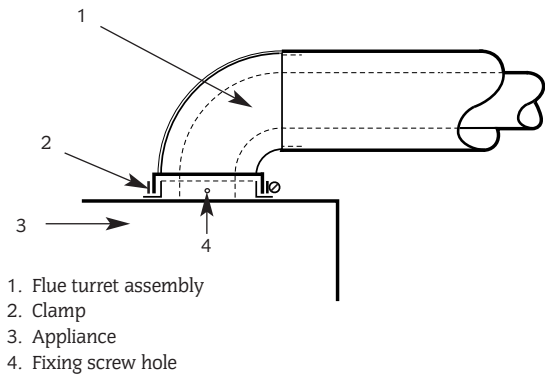
### 11.2.12 Installation of Flue onto Boiler

- (i) Fit the clamping ring around the flue spigot but leave loose. From the inside push the assembly through the wall. Align the flue turret and push fully onto the spigot on the appliance.
- (ii) Slide the clamping ring into position so that the hole in the spigot lines up with the hole in the ring. Tighten the ring in this position. Through the fixing hole screw the self drilling screw into the flue (see Fig. 29).
- (iii) Remove the fan from the fan/fluehood assembly by removing the two fan flange fixing screws and also releasing the fan clamping bracket.
- (iv) Disconnect the two end lengths of the pressure sensing hoses up to and the connection joints (approx 150mm of hose). Both of these hoses should be discarded. Refer to Fig. 16.
- (v) Slide the flue hood only back into the boiler facing the opposite way to before. Ensure that the flue hood hits the stops at the rear and the rear combustion chamber slots in underneath (see Fig. 28).
- (vi) With the fluehood on the boiler refit the fan:
  - (a) Remove the fan lead from the top clip.
  - (b) With the fan in close proximity to the fluehood re-attach the fan electrical terminals to the fan. The polarity of the connection to the fan motor is not important.
  - (c) Refit the the fan onto the fluehood. The rear flange should slide into the clips at the rear of the flue hood.
  - (d) The fan should then slide upwards into the flue outlet to enable the fan clamp to be fitted and tightened into position.
- (vii) Re-assemble the front combustion chamber with the 'j' bolts and replace inner case door.

**Fig. 28 . Fan/Flue hood Assembly with Flue Turret Kit**



**Fig.29 . Flue Turret Fixing .**



### 11.2.13 Completion of the Installation

Check that all the gas and water connections have been tightened.

Lower the base plate/control panel. Refer to Fig. 30.

The permanent mains and switched live supply to the boiler must come from the system junction box. Refer to Fig.11. A 4 core cable is recommended.

Feed the 4 core cable and the pump cables through the bracket and secure in the cable clamp. Refer to Fig. 30.

Fit all the supply and pump wires to the 5 way plug before fitting the plug to the socket on the board. This will avoid stress to the board when using a screwdriver. Refer to Fig.11. for the connections.

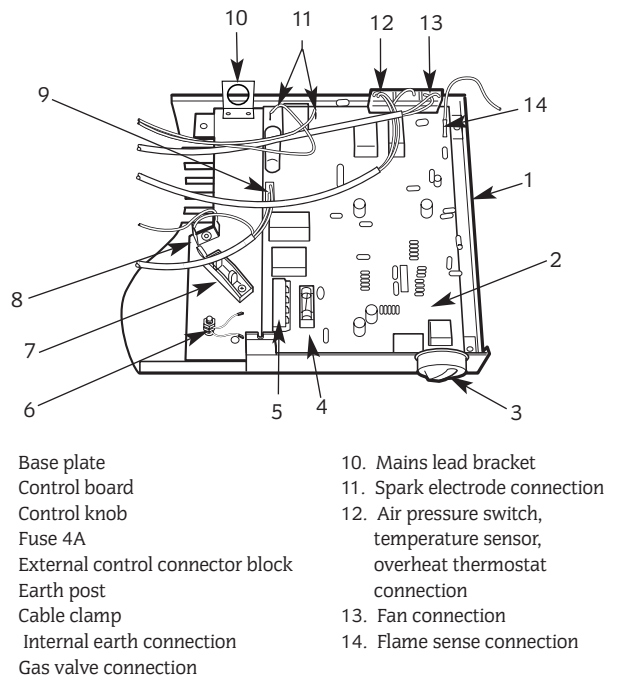
Check that all the cables cannot touch the inner casing.

Test for gas soundness as described in BS6891.

If the appliance is not commissioned immediately, refit the combustion cover, inner casing cover, base/controls assembly and the casing. Re-connect the earth connection at the base of the casing. Check that the gas and electricity services have been turned off.

### REFER NOW TO SECTION 12 - COMMISSIONING THE APPLIANCE

**Fig. 30 . Mains electricity and controls connections.**



## 12. Commissioning The Appliance

### **benchmark** Cleansing and Inhibiting a Central Heating Installation in compliance with Benchmark

It is accepted good practice in compliance with BS 7593, Pas 33 and Benchmark, to cleanse both an existing central heating system when fitting a replacement boiler, and when fitting a new central heating system. Then treat with a 'Corrosion Protector'. Worcester recommend only products from water treatment manufacturers participating in Benchmark. These include:

Fernox	Sentinel
Alpha-Fry Technologies	Betz Dearborn Ltd
Tandem House	Foundry Lane
Marlowe Way	Widnes
Beddington Farm Road	Cheshire
Croydon	WA8 8UD
CRO 4XS	
Tel: 01799 521133	Tel: 0151 424 5351

Please call either of the above for a specific cleansing method statement if so required. Below is a general guide for flushing, which we would advise you to follow along with the chemical manufacturers recommendations.

Fill up and commission the system in the normal way, i.e: flush at least once without firing the boiler to remove loose debris.

Then add the cleansing agent, with regard to COSHH, this must be in the system for a minimum of 1 hour with the system at normal operating temperature. A longer period of time, up to 48 hours, would be more beneficial to the cleansing process, especially if heavy sludge deposits are suspected to be present (see water analysis kit).

Drain the system thoroughly at least twice to remove the cleansing agent and any debris/flux present. This is a crucial part of the cleansing process and must be done correctly. A TDS meter is recommended to ensure adequate flushing.

Once you are sure that the system has been cleansed thoroughly, then add a mixed metal corrosion protector. This will protect against the formation of scale, corrosion and microbiological growths. A minimum of one treatment should be added per system.

The label that is supplied by the manufacturer with the corrosion protector treatment, shall be correctly filled in and attached to the boiler. Also, the instructions in the Benchmark logbook will be adhered to.

Please note that the corrosion protector level should be checked on an annual basis. This is normally done at the time of the mandatory boiler service. Water analysis test kits and postal analysis services are available from water treatment suppliers for this purpose.

Failure to comply with these recommendations, may invalidate the boiler warranty. If any of the above is unclear, then please contact The Worcester Technical Services for further advice.

**12.1 Remove the outer casing by first loosening the base screw.** Disconnect the earth and lift off the casing. Check that the electricity and gas supplies to the appliance are turned off and that all the water connections throughout the system are tight.

Open any system valves.

Open all the radiator valves. Remove any air vent caps.

If a sealed system has been installed then fill through a WRc approved filling kit to an initial pressure of 2.5bar.

Check for water soundness throughout the system.

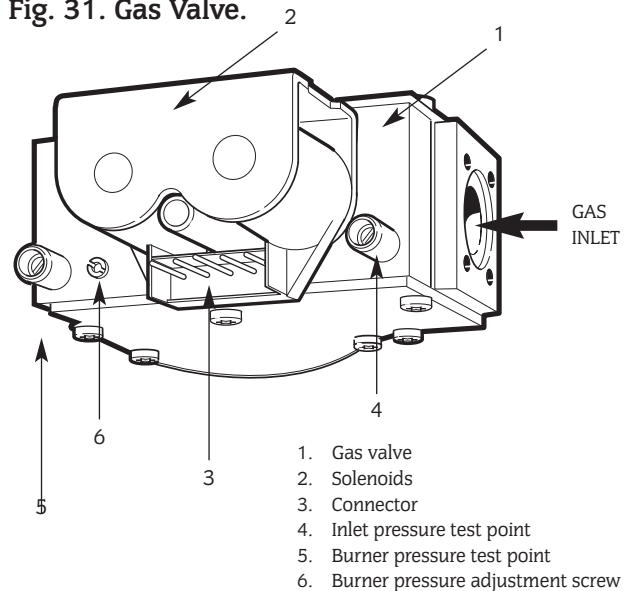
Vent each radiator in turn.

Remove the cap from the pump and turn the shaft about half a turn. Replace the cap.

Check that the relief valve (sealed system) operates by turning the knob anti-clockwise until it releases.

### **12.2 Set the Expansion Vessel Pressure - Sealed System**

Fig. 31. Gas Valve.



The

charge pressure of an expansion vessel is usually 0.5bar, which is equivalent to a static head of 5m [17ft].

The charge pressure must not be less than the static head at the point of connection. The expansion vessel must be charged to 0.3bar less than the initial system design pressure.

Note: 1bar = 10.2m = 33.5ft of water.

### **12.3 Set the System Pressure**

Fill the system initially until the pressure gauge is at 2.5bar and check for leaks. Release water through the drain cock until the required system pressure is obtained, up to a maximum of 1.5bar.

Set the pointer on the pressure gauge to record the set system pressure. If the pressure indicated on the gauge is greater than 2.65bar when operating at the maximum central heating temperature, the expansion vessel is too small and a larger vessel must be fitted. The boiler with a 10 litre expansion vessel can accommodate a sealed system volume of about 90 litres. Refer to BS7074 Part 1, BS5449 and Table 9.

### **12.4 Clock/Programmer**

Any controls fitted to the system should be set up at this stage.

### **12.5 Check that the gas and electricity supplies are turned off.**

Connect a pressure gauge to the burner pressure test point on the gas valve. Refer to Fig. 31.

### **12.6 Light the Boiler**

Switch on the gas and electricity supply.

Set the temperature control knob to maximum and any clocks or programmer to operate continuously.

The gas supply pipe will be purged by the boiler.

The control will work as follows:

- (i) Pre-purge (air) for approximately 20 seconds.
- (ii) Spark and gas for approximately 5 seconds
- (iii) Purge (air) for approximately 10 seconds

**The boiler will attempt to light a maximum of 5 times before going to lockout. To reset the product turn the control knob fully anti-clockwise and back.**

**NOTE:** The burner pressure is factory set and may be reset to match the system requirements. If, after checking that the supply pressure is sufficient i.e. 19 mbar approx [NG] or 36 mbar approx [PROPANE] at the gas valve inlet pressure test point, the required pressure cannot be obtained then contact The Worcester Service Department Tel: 08705 266241.

Reset the pressure as necessary by adjusting the screw on the gas valve. Refer to Table 1 and Fig.31.

### **12.7 Domestic Hot Water**

Check that the cylinder thermostat, if fitted, is set to between 55°C and 60°C.

Check that all external controls are calling for heat and that the flow pipe to the cylinder is hot after a short period.

### 12.8 Central Heating

Check that the external controls are calling for heat to the heating circuit.

Check that all the radiators heat up evenly. If necessary carefully vent.

**12.9** Balance the system to give the correct temperature differential. Refer to Table 3. Refer to Section 7. for bypass requirements.

**12.10** Set the room thermostat to minimum and check that the burner goes out. Reset the room thermostat and the burner will re-light. Turn off the gas service cock at the boiler. The burner will go out but, after a short pause, the appliance will make 5 attempts to restart sparking for 5 seconds and then 'lock-out'. After 60 seconds carefully open the gas service cock at the boiler, operate the reset control and observe the burner re-light and follow the normal sequence of operation. Refer to Fig. 32.

Turn off the gas service cock at the boiler and the electricity supply to the appliance.

Drain the system while the appliance is hot.

Refill, vent and re-pressurise the system (Sealed System) adding a suitable proprietary inhibitor. Further information is available from Worcester Technical Information Dept, Telephone 08705 266241.

### 12.11 Completion of Commissioning

Disconnect the pressure gauge from the gas valve and tighten the test point screw.

Restart the appliance and check for gas soundness around the test point screw.

Fix the red arrow on the data plate to show the boiler setting. If the setting has been altered the adjustment screw should be re-sealed by a dab of paint to stop un-authorized adjustment.

Refit the casing, reconnect the earth and tighten the clip.

If the appliance is to be passed over to the user immediately then set any controls to the users requirements.

If the appliance is to be left inoperative in frosty conditions then set a programmer, if fitted, to continuous and the appliance to operate at a low temperature under the control of a frost thermostat, if fitted, to protect remote parts of the system.

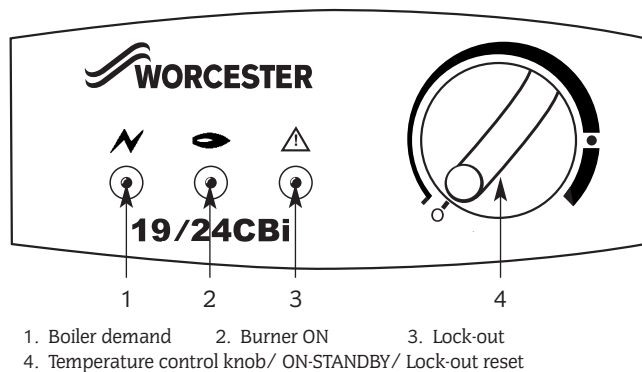
The boiler has its own integral frost protection which will also protect a compact system.

If there is any possibility of the appliance being left totally unused in freezing conditions then switch off the gas and electricity and drain the appliance and the system.

Complete the Benchmark Log-book.

## 13. Instructions To The User

Fig. 32. User controls.



**benchmark**

**13.1** Hand over the User Booklet and the Benchmark Log-book and explain how to operate the appliance safely and efficiently.

**13.3** Tell the user what to do if the appliance is not to be used in very cold conditions.

**13.4** Tell the user what to do if the system (Sealed System)

pressure falls.

**13.5** Explain that regular servicing, of a maximum of 12 months between services, will maintain the safe and efficient operation and extend the life of the appliance. Worcester can offer a comprehensive maintenance contract.

**13.6** Tell the user that any work on the appliance must only be carried out by a competent person.

## 14. Inspection And Service

**14.1** The extent of the service will be determined by the operating condition of the appliance. It is the law that any service work is carried out by a competent person.

### 14.2 Inspection

Check that the terminal and the terminal guard, if fitted, are clear and undamaged.

If the appliance is in a compartment or cupboard check that the specified clearances are clear. Refer to Table 7 and Section 6 Air Supply.

Check all the joints and connections in the system and remake any that show signs of leakage. Refill and re-pressurise (Sealed System) as described in Section 12 Commissioning.

Operate the appliance and take note of any irregularities. Refer to Section 18-Fault Finding.

Check the combustion performance

Lift off the cap from the sample point on the top of the boiler and connect the meter. Refer to Fig 30/30a.

With the appliance at maximum rate and stable expect readings of about:

APPLIANCE	SHORT FLUE WITH RESTRICTOR PLATE FITTED		LONG FLUE WITHOUT RESTRICTOR PLATE FITTED	
	CO	CO <sub>2</sub>	CO	CO <sub>2</sub>
9/14Cbi NG	0.003 - 0.007	7.2 - 8.1	0.002 - 0.005	6.0 - 6.8
LPG	0.003 - 0.007	8.1 - 8.7	0.002 - 0.005	6.9 - 7.7
14/19Cbi NG	0.002 - 0.005	6.6 - 7.5	0.002 - 0.005	5.6 - 6.5
LPG	0.002 - 0.005	7.8 - 8.5	0.002 - 0.005	6.3 - 7.0
19/24Cbi NG	0.008 - 0.012	7.1 - 7.7	0.008 - 0.012	7.0 - 7.8
LPG	0.005 - 0.010	8.0 - 8.9	0.008 - 0.015	7.8 - 8.5

Refit the sample point cap after the test.

Always test for gas soundness after the service has been completed.

Disconnect the electrical supply at the mains and turn off the gas supply at the gas service cock on the appliance before starting any service procedures.

### 14.3 Component Access

Ensure that the gas and electricity supplies are isolated before accessing the following parts.

Remove some or all of the following parts to gain access to the components.

**Outer Case.** Loosen the screw and clip at the base, disconnect the earth tag, lift the case up and pull forwards.

**Base/Control Assembly.** Remove the single screw and lower. Refer to Fig. 33a/b.

**Inner Case Door.** Remove the four corner screws and lift the door off.

**Combustion Chamber Front Cover.** Loosen the two wing-nuts and slide the 'J' bolts out of the slots. Pull the front cover forwards and upwards to remove from the boiler.

**NOTE:** On the 9/14Cbi the RHS bolt and clamping bracket must be removed.

**Fan - Rear Only Flue.** Remove the combustion chamber front cover. Carefully pull off the electrical connections and the pressure tubes from the air flow detector. Slide out the fan and flue hood assembly. Ensure that the combustion chamber rear fits under the lip on the fluehood. To remove the fan, remove the two fixing screws and release the clamping bracket.

**Fan - Simplefit Horizontal Flue.** Remove the combustion chamber cover. Carefully pull off the electrical connections and the tubes from the air flow detector. Loosen the two clamps to remove the fan. Refer to Fig 34.

**Flue Hood - Simplefit Horizontal Flue.** Remove the fan, see above. Remove the combustion chamber cover and withdraw the hood. When refitting ensure that the combustion front fits under the lip of the flue hood.

**Burner Blade Assembly.** Remove the combustion chamber cover. Undo the screw at the right hand end of the burner. Carefully pull-off the connections to the spark electrode. Slide the burner blade assembly off the injector and remove. Carefully pull off the flame sense electrode lead. Refer to Fig 33/33a.

**Control Board Cover.** To gain access to the control board remove cover from the front clip, with a screwdriver (if necessary) and unclip from the rear of the controls tray.

#### 14.4 Component Cleaning

Do not use a brush with metal bristles to clean components.

Clean the fan taking care not to block air flow detector.

Clean the burner to ensure that the blades are clear. Do not use a metal probe to clean the injector.

Clean the electrodes and check the alignment. Replace if there is any sign of deterioration.

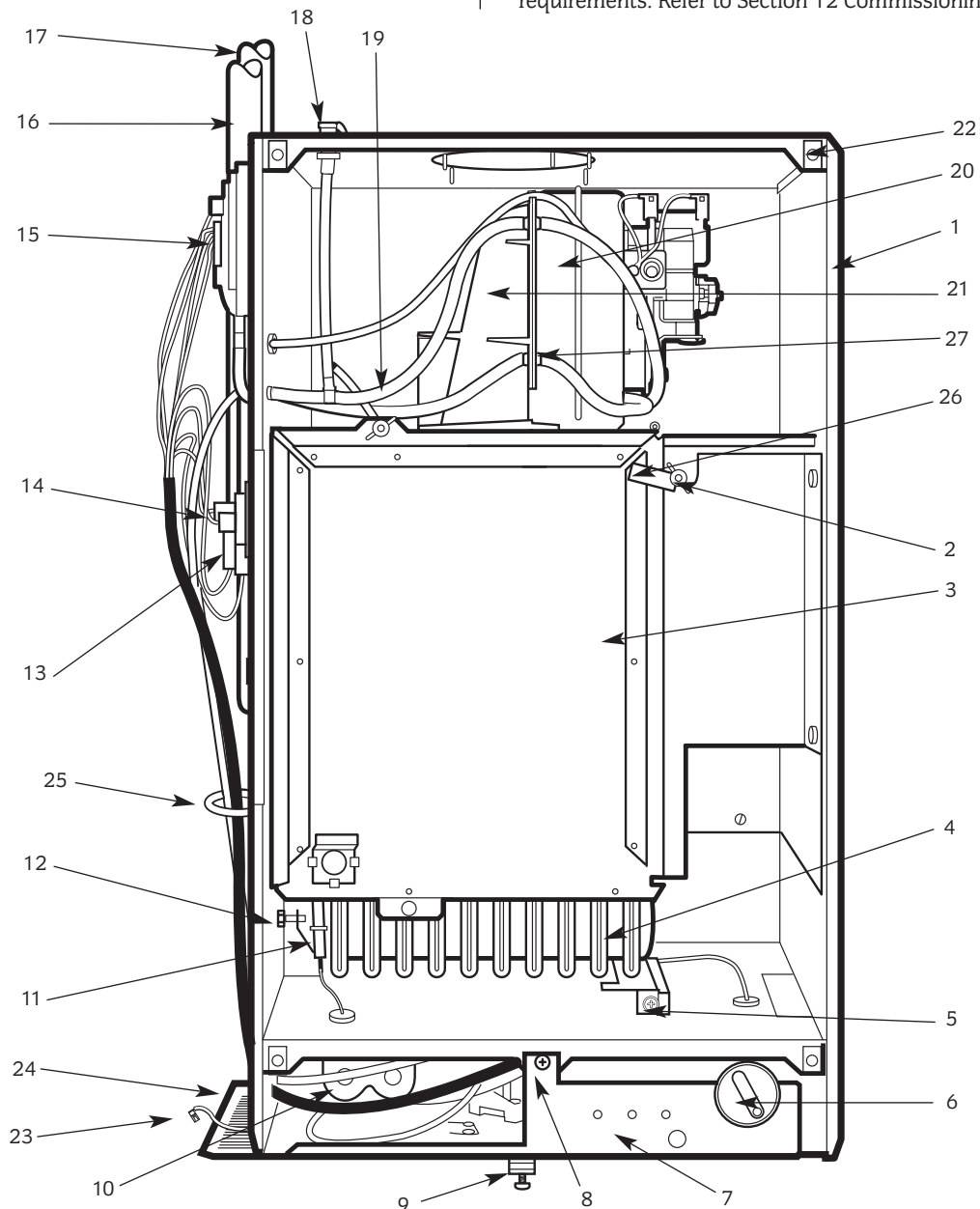
Clean the heat exchanger from top and bottom after covering the burner injector. To clean the heat exchanger flueways remove the stainless steel baffles from the appliance - the rear combustion chamber cover can be tilted for better access. The front and rear flueways can be cleaned with a brush being careful to protect the rear combustion chamber insulation. The inner flueway can be cleaned with a scraper.

Check the combustion chamber insulation and replace if there is any sign of damage or deterioration. Refer to Section 15.4.11. Carefully refit any components removed and check that all screws are tight and the connections properly re-made with the appropriate gaskets/O-rings/seals.

Re-commission, as necessary, for correct operation to the users requirements. Refer to Section 12 Commissioning.

**Fig. 33a. Inner Casing and control**

9/14CBI



- |                              |                               |                           |  |
|------------------------------|-------------------------------|---------------------------|--|
| 1. Inner case                | 8. Base/controls fixing screw | 15. Air pressure switch   | 22. Inner case cover fixing points (4) |
| 2. J bolts and wing nuts (2) | 9. Cabinet fixing screw       | 16. Flow pipe             | 23. Outer case earth tag               |
| 3. Combustion chamber cover  | 10. Gas valve                 | 17. Return pipe           | 24. Side cover plate                   |
| 4. Burner                    | 11. Spark electrode           | 18. Combustion test point | 25. Wire clip                          |
| 5. Burner fixing screw       | 12. Burner injector           | 19. Sensing tubes         | 26. 9/14CBI clamping bracket           |
| 6. Control knob              | 13. Temperature sensor        | 20. Fan                   | 27. Pressure tube junction             |
| 7. Indicator lights          | 14. Overheat thermostat       | 21. Flue hood             |  |

## 15. Replacement Of Parts

**Important:** Turn off the gas and electricity supplies and drain, where necessary, before replacing any components.

**15.1** Always check for gas soundness where relevant and carry out functional checks as described in Section 12 Commissioning. Any O-ring, gasket or seal that appears damaged must be replaced.

### 15.2 Component Access

Refer to Section 14.3 Inspection and Servicing for access to components.

### 15.3 Draining the Appliance

Isolate the appliance.

Remove the casing. Refer to Section 14.3.

Fit a tube to the drain connection from the system (top connection only) and open the tap. Refer to Fig 34. Close the tap when the flow has stopped.

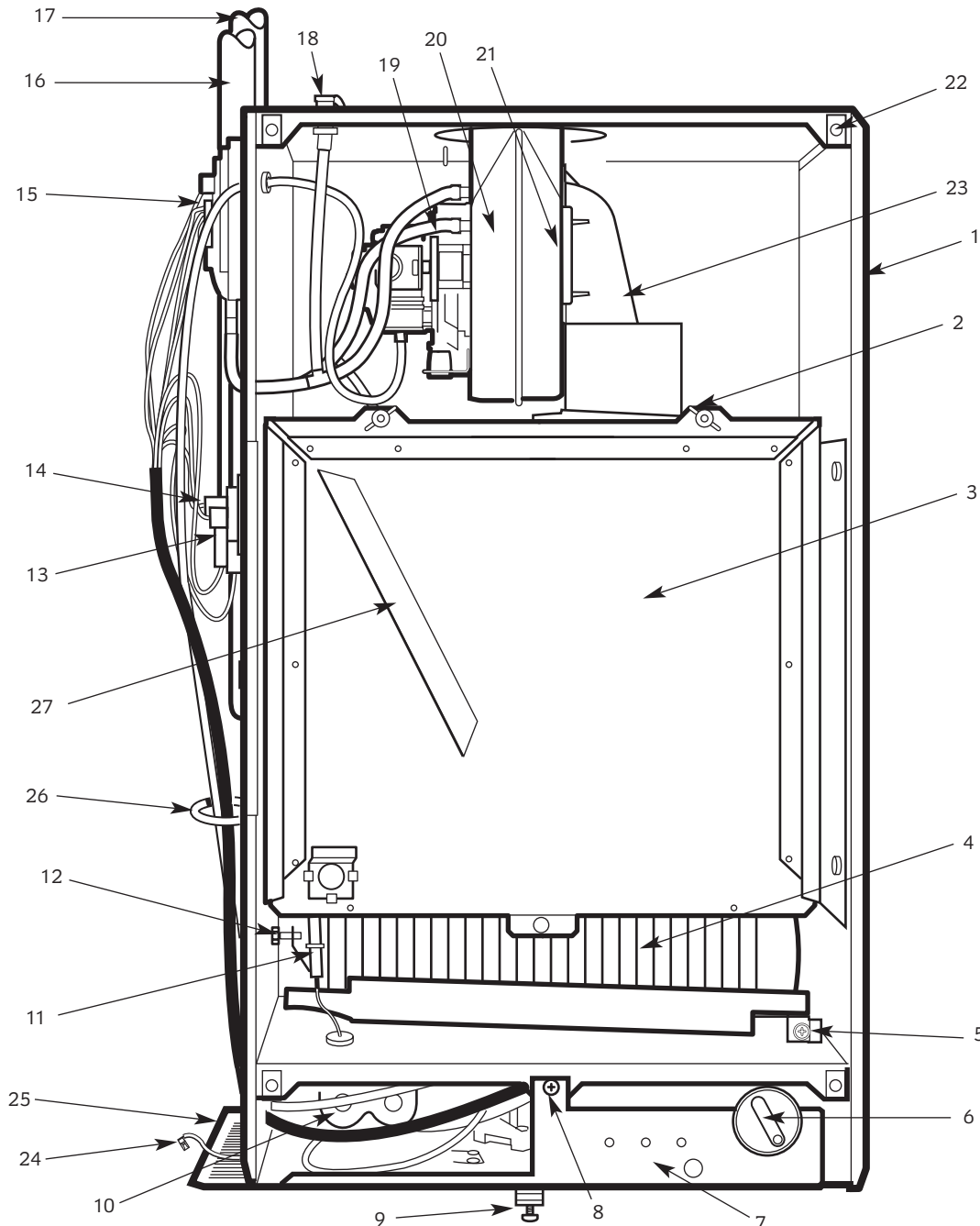
**IMPORTANT:** A small quantity of water will remain in some components. Protect any electrical components when removing items that might retain water.

### 15.4 Component Replacement

Replace any components removed from the appliance in the reverse order using new gaskets/O-rings/sealant/heat transfer paste where necessary. Always check that any electrical connections are correctly made and that all screws are tight.

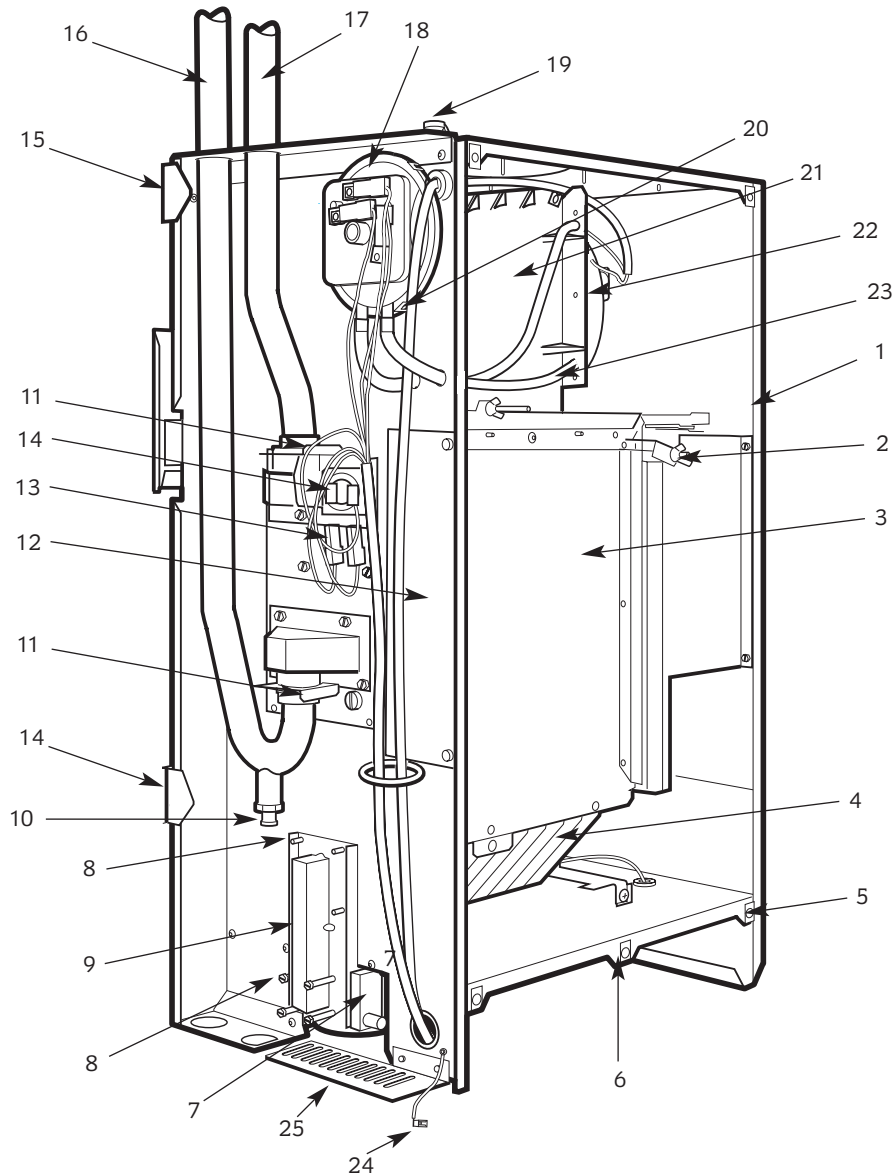
**Fig. 33b. Inner Casing and control**

14/19 and 19/24Cbi



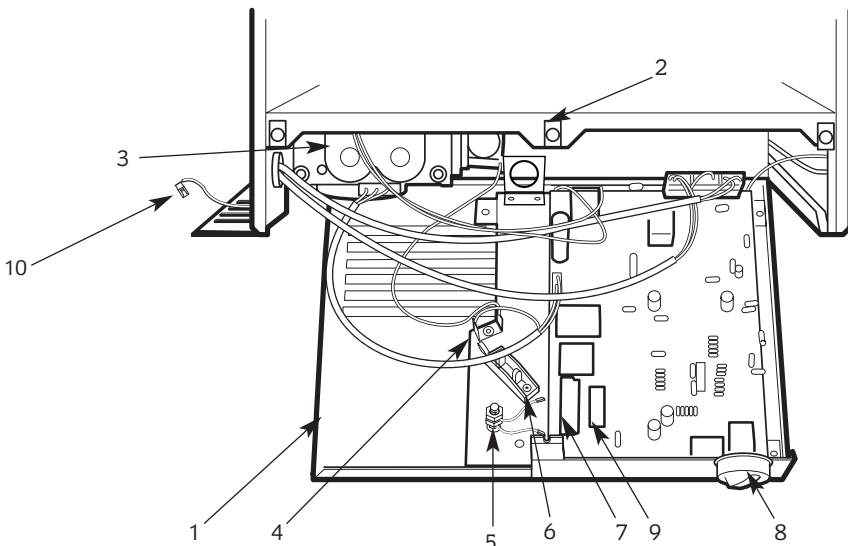
- |                              |                               |                           |  |
|------------------------------|-------------------------------|---------------------------|--|
| 1. Inner case                | 8. Base/controls fixing screw | 15. Air pressure switch   | 22. Inner case cover fixing points (4) |
| 2. J bolts and wing nuts (2) | 9. Cabinet fixing screw       | 16. Flow pipe             | 23. Flue hood                          |
| 3. Combustion chamber cover  | 10. Gas valve                 | 17. Return pipe           | 24. Outer case earth tag               |
| 4. Burner                    | 11. Spark electrode           | 18. Combustion test point | 25. Side cover plate                   |
| 5. Burner fixing screw       | 12. Burner injector           | 19. Sensing tubes         | 26. Wire clip                          |
| 6. Control knob              | 13. Temperature sensor        | 20. Fan                   | 27. Front baffle                       |
| 7. Indicator lights          | 14. Overheat thermostat       | 21. Fan clamp (2 screws)  |  |

**Fig. 34 . Inner Casing - Gas and Electric Controls. 9/14CBi shown.**



1. Inner casing
2. J bolts and wing nuts (2)
3. Combustion chamber cover
4. Burner assembly
5. Inner case cover fixing points (4)
6. Base/control fixing point
7. Gas valve
8. Burner manifold fixing screws (4 + 4)
9. Burner manifold
10. Drain point (top flow return)
11. Flow and return pipe fixing clip
12. Access panel
13. Temperature sensor
14. Overheat thermostat
15. Casing support
16. Return pipe
17. Flow pipe
18. Air pressure switch
19. Combustion test point
20. Air pressure switch fixing clip (4)
21. Flue hood
22. Fan
23. Sensing tubes
24. Outer case earth tag
25. Side cover plate

**Fig. 35 . Base/Control Board Assembly**



1. Base/control assembly
2. Base/control assembly fixing point
3. Gas valve
4. Inner connections earth tag
5. External controls earth post points (4)
6. Cable clamp
7. External controls connection
8. Control knob
9. Fuse
10. Outer case earth tag

**NOTE:** Control board cover not shown.

### 15.4.1 Gas Valve

**NOTE:** If the left hand clearance is >50mm then the gas valve can be replaced with the burner and combustion chamber cover in place by unscrewing the four extended screws at the manifold on the outside of the inner casing. The manifold gasket should be replaced if it is damaged or has deteriorated.

Check that the gas supply is isolated.

Remove the inner casing cover, the combustion chamber cover and the burner blade assembly. Refer to Section 14.3.

Unscrew and lower the base plate/control assembly.

Unplug the electrical connection at the gas valve.

Unscrew and remove the side plate adjacent to the manifold.

Undo the four screws securing the gas cock to the valve. Take care not to damage the control panel.

Undo the four pozi-head screws to remove the gas valve and burner manifold assembly.

Undo the four pozi-head screws inside the casing to separate the gas valve from the manifold.

Use new O-rings when replacing the valve.

Set the Gas Valve:

Connect a pressure gauge to the burner pressure test point on the valve. Refer to Fig. 31.

Switch on the gas and electricity supplies. Check for gas soundness at the gas valve inlet.

Refer to Section 12 Commissioning for the method of checking the pressures.

Check for gas soundness at the gas valve outlet.

Adjust the gas valve to obtain the required pressure. Refer to the data plate on the cabinet where required pressure will be indicated.

Alter the red arrow if a new setting is made.

The adjustment screw must be sealed by a dab of paint to stop unauthorized adjustment.

Switch off the appliance, disconnect the pressure gauge and tighten the test point screw. Refer to Fig. 31.

Check for gas soundness.

### 15.4.2 Spark Electrode

Remove the inner casing cover and the combustion chamber cover.

Carefully pull off the leads at the electrodes. Remove the burner blade assembly. Refer to Section 14.3.

Unscrew and remove the electrode assembly. Refer to Fig. 36 and 36a.

### 15.4.3 Flame Sense Electrode

Remove the inner casing cover and the combustion chamber cover.

Pull off the connections to the spark electrode. Carefully remove the burner blade assembly. Refer to Section 14.3.

Carefully pull off the lead from the electrode.

Unscrew and remove the electrode assembly. Refer to Fig. 36 and 36a.

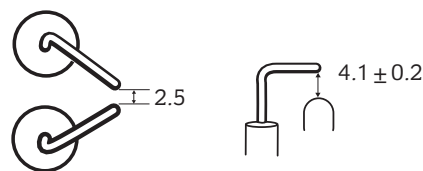
Ensure that the new electrode is at the correct height and position on the burner blade.

### 15.4.4 Burner Blade Assembly

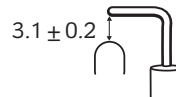
Remove the inner casing cover and the combustion chamber cover.

Remove the burner blade assembly. Refer to Section 14.3.

#### Spark Electrode Gaps

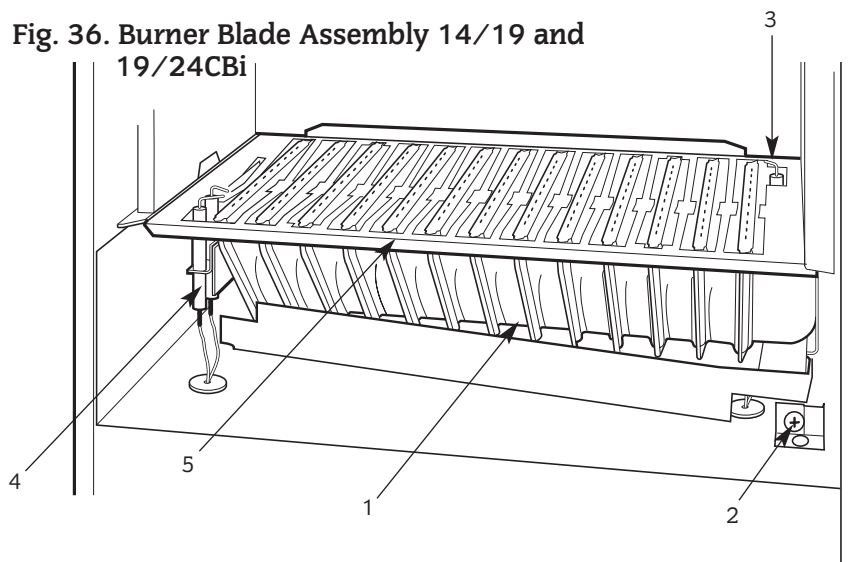


#### Flame Sense Electrode Gap

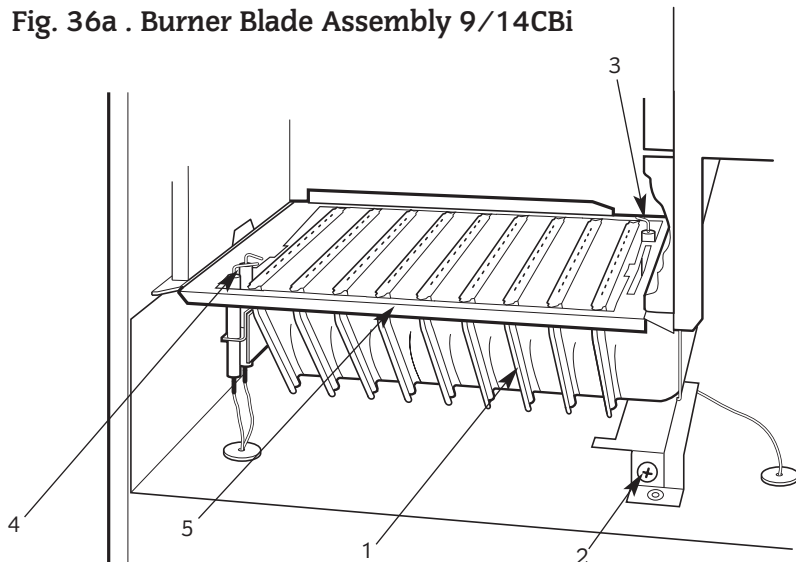


1. Burner blade assembly
2. Burner fixing screw
3. Flame sense electrode
4. Spark electrode
5. Burner baffle (not removable from the burner)

**Fig. 36. Burner Blade Assembly 14/19 and 19/24CBi**

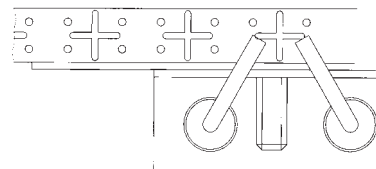


**Fig. 36a . Burner Blade Assembly 9/14CBi**



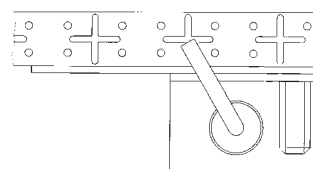
#### Spark Electrode Position

##### Both Burners



#### Flame Sense Electrode Position

##### Both Burners



### 15.4.5 Control Board

Lower the base plate/control assembly and carefully disconnect the plug-in connector and all the electrical connections. Refer to Fig. 35.

Release the five clips and lift out the control board. Refer to Fig. 35.

Pull out and replace, if necessary, a failed fuse.

### 15.4.6 Fan

Remove the inner casing and combustion chamber cover .

Remove the fan as described in Section 14.3 Inspection and Servicing. The flue hood gasket should be replaced if it is damaged or has deteriorated.

Ensure that all the connections are correctly made to the new fan. Refer to Fig. 37 and 37a.

Do not use any sealant on the fan/flue duct connection.

The polarity of wires onto the fan is not important.

Fig. 37 . Fan/Flue hood Assembly with *Simplefit* Horizontal Flue

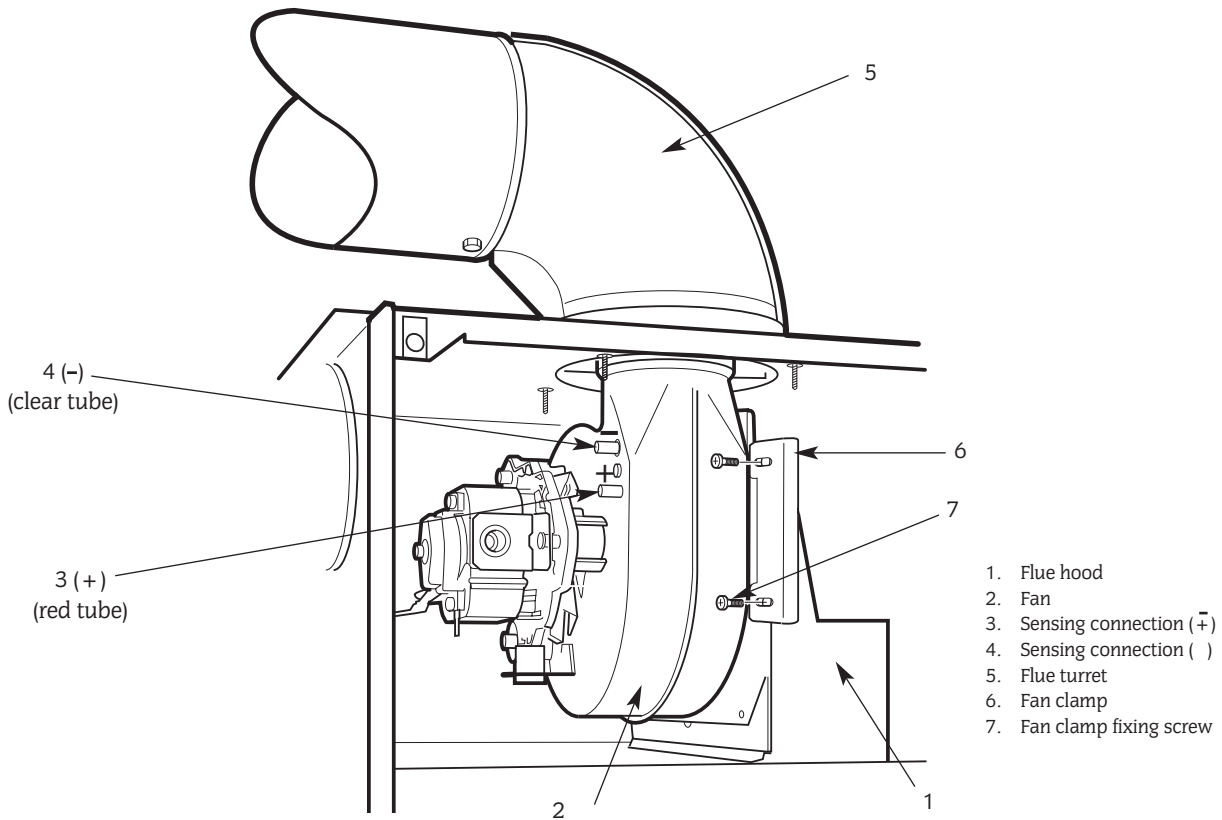
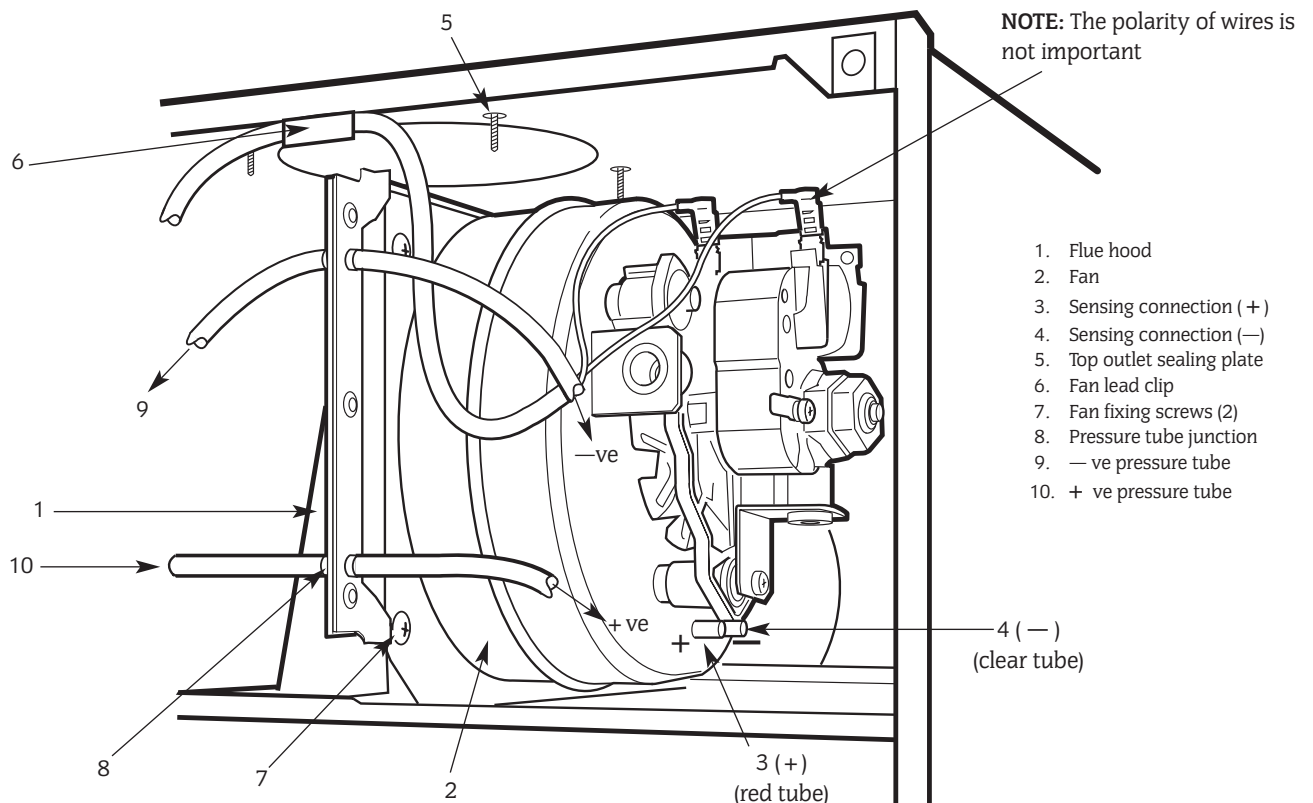


Fig. 37a . Fan/Flue hood Assembly with Rear Only Flue



### 15.4.7 Air Flow Sensor

Remove the fan as described in 14.3. Unscrew and withdraw, through the fan outlet, the air flow sensor. Refer to Fig .38 and 38a.

The detector is 'handed' - do not force it into place.

Fig. 38 - 9/14CBi

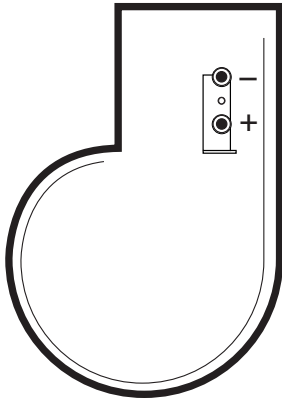
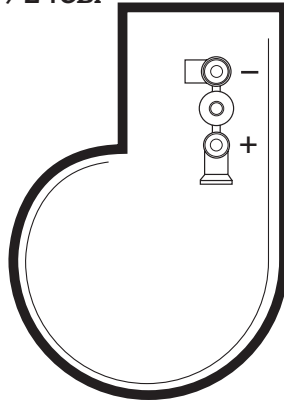


Fig. 38a - 14/19 and 19/24CBi



### 15.4.8 Temperature Sensor

Remove the access panel to give improved access with minimum side clearance.

Carefully pull-off the connections.

Remove grommet.

Pull off the clip and remove the sensor. Refer to Fig .39.

When replacing component ensure heat sink compound is added around contact area.

### 15.4.9 Overheat Thermostat

Remove the access panel to give improved access with minimum side clearance.

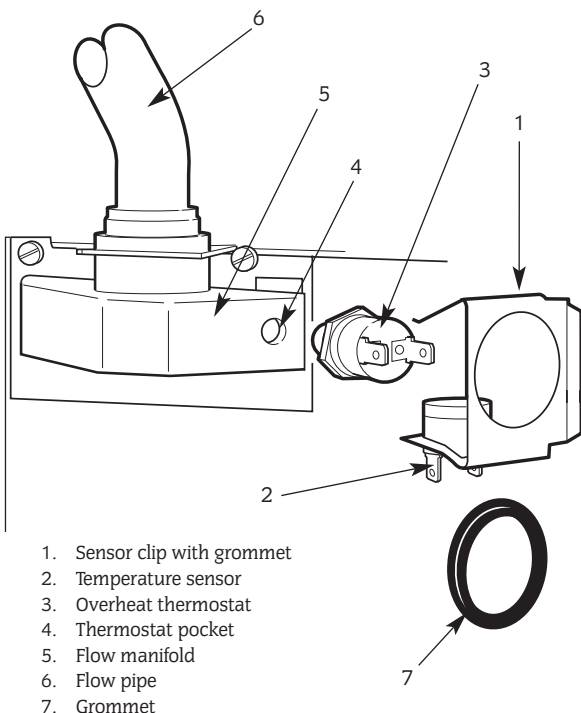
Carefully pull-off the connections.

Remove grommet.

Unscrew and remove the sensor (see above).

When replacing component ensure heat sink compound is added around contact area.

Fig. 39. Sensor and Overheat Thermostat



1. Sensor clip with grommet
2. Temperature sensor
3. Overheat thermostat
4. Thermostat pocket
5. Flow manifold
6. Flow pipe
7. Grommet

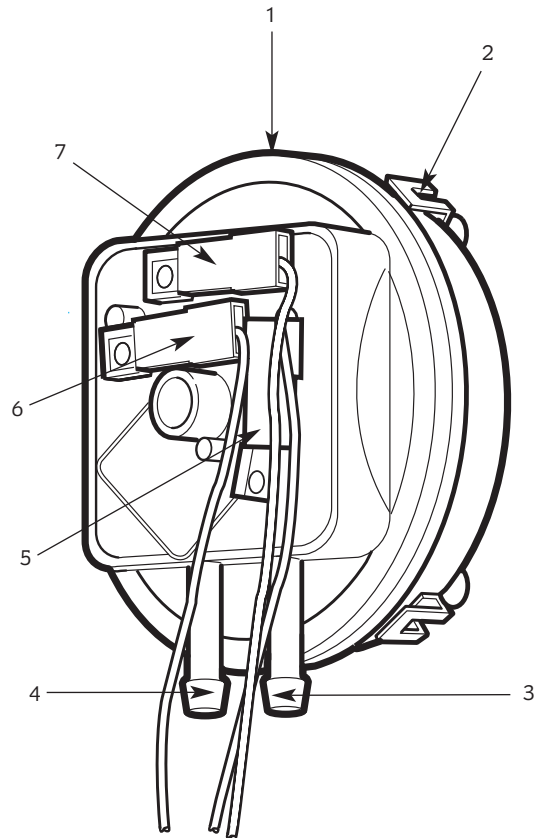
### 15.4.10 Air Pressure Switch

Noting the position of each pressure tube carefully disconnect the tubes and electrical connections from the switch. Unclip and remove the switch if there is more than 50mm clearance. Refer to Fig.40.

If there is minimum clearance then remove the inner casing cover and release the two screws. Remove the air pressure switch and mounting bracket complete.

Ensure that the connections are correctly made on the replacement switch. Red tube to the connection marked (+) and the clear tube to the connection marked (-).

Fig. 40. Air Pressure Switch



1. Air pressure switch
2. Fixing clips (4) - mounting bracket
3. Sensing tube connection - clear to '-' on fan
4. Sensing tube connection - red to '+' on fan
5. Electrical connection COM - brown
6. Electrical connection NO - grey
7. Electrical connection NC - white

### 15.4.11 Combustion Chamber Insulation

The insulation pads are manufactured from a material in accordance with COSHH.

Remove the casing, inner casing cover and combustion chamber cover.

**Front Insulation:** Unscrew the clamp at the top of the combustion chamber cover to replace insulation.

**Side Insulation:** Release the clip at the bottom and slide out the insulation.

**Rear Insulation:** Remove the burner blade assembly and cover the burner injector.  
Remove the fan and flue hood assembly.  
Remove the side insulation pads.  
Unscrew the combustion chamber rear panel and lower.  
Cut the rear insulation board to remove it from the boiler.  
Cut the replacement board approximately 90mm from the top so that the joint will be behind the heat exchanger.  
Slide in the top section followed by the bottom section.  
Refer to Fig.37.  
On replacement ensure that the fixing screw returns through the hole in the rear bracket.

### 15.4.12 Heat Exchanger

Shut off the gas and electricity supplies.

Drain the appliance.

Protect the electrical components.

**NOTE: Some water will remain in the heat exchanger.**

Remove the casing, inner casing cover, combustion chamber cover, heat exchanger baffles, fan and flue hood assembly, burner blade assembly and the access plate at the left hand side of the inner casing.

Pull off the leads from the sensor and overheat thermostats. Pull off the clip to remove the sensor and unscrew the overheat thermostat.

Pull out the clips securing the flow and return pipes and remove them from the manifolds. It will be necessary to disconnect the pipes from the system adjacent to the boiler.

Unscrew the slotted hex head screw at the base of the combustion chamber rear panel.

Slide the panel upwards and unscrew the two screws exposed at the right and left hand sides at the rear.

Unscrew the four hex head screws, two at each side, securing the steel side plates to the inner casing.

Lower the combustion chamber rear panel by pulling the lower fixing point in front of the securing bracket.

Unscrew the two M6 nuts whilst supporting the heat exchanger (the approximate weight is: 9/14CBi - 18kg, 14/19 and 19/24CBi - 24kg).

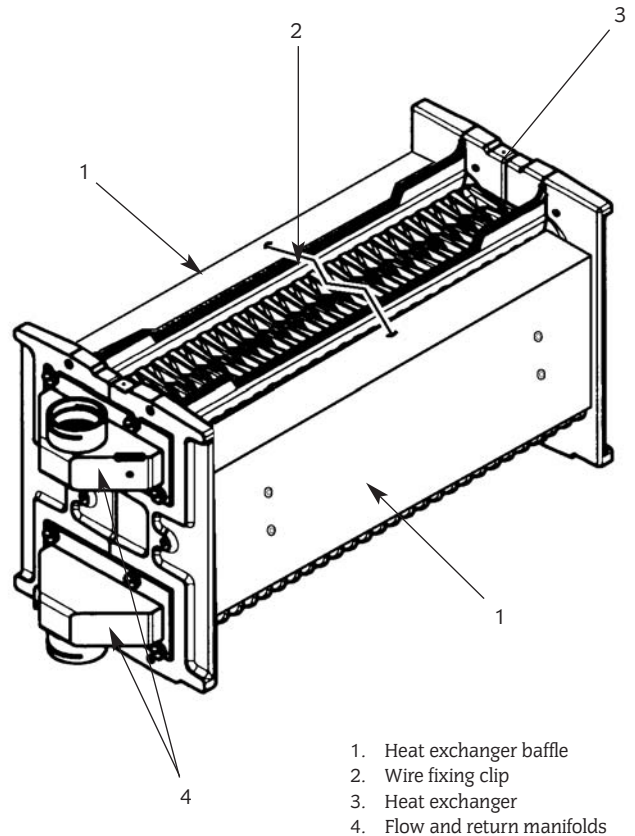
Lift out the heat exchanger assembly complete with side plates and manifolds. Take care as the combustion chamber rear panel is now unattached.

Transfer the side plates to the new heat exchanger

Fit the new heat exchanger in the reverse order.

Re-commission the appliance. Refer to Section 12.

Fig. 41. Heat Exchanger Baffles in Position on the Heat Exchanger



## 16. Conversion Instructions

These instructions should only be read if converting appliance from Natural Gas to LPG or vice versa.

Only components supplied by Worcester, Bosch Group should be used.

Only competent persons should attempt the conversion.

**Conversion from Natural Gas to LPG should not be carried out on appliances installed in a room or internal space below ground level.**

Turn off the gas and electricity supplies to the boiler.

**NOTE:** Turning the control knob to off does not isolate the boiler.

### 16.1 Conversion

- (I) Remove the outer casing by loosening the fixing screw at the base and lifting off. Refer to Fig. 12a/b.
- (II) Remove the inner casing door and combustion chamber front. Refer to Section 14.3.
- (III) Lower the base/control assembly. Refer to Section 14.3.
- (IV) Remove the burner blade assembly. Refer to Section 14.3.
- (V) Unscrew and replace the burner injector and washer with the new one from the kit. Refer to Tables 9 and 10.

- (VI) Transfer the spark and flame electrode assemblies to the new burner blade assembly. Refer to Sections 15.4.2 - 4 for details of positions.
- (VII) Fit the new burner blade assembly into the appliance not forgetting to re-connect the electrode leads.
- (VIII) Refit the combustion chamber front and inner case cover.
- (IX) Switch on the gas supply and open the gas cock at the appliance. Check for leaks at the gas valve inlet.
- (X) Refit the base control assembly.
- (XI) Recommission the appliance. Refer to Section 12. Commissioning for details. Adjust the burner setting pressure as required. Refer to Table 1 and Fig. 31.
- (XII) Fix the Red Arrow on the data plate to show the boiler setting. If the setting has been altered the adjustment screw should be resealed by a dab of paint to stop unauthorized adjustment.
- (XIII) If converting to an LPG boiler add LPG sticker to the casing door. If converting from LPG to NG then remove the LPG sticker from the casing door.
- (XIV) Refit the cabinet casing.
- (XV) Complete the Benchmark checklist.

**Table 9. Conversion from LPG — NG**

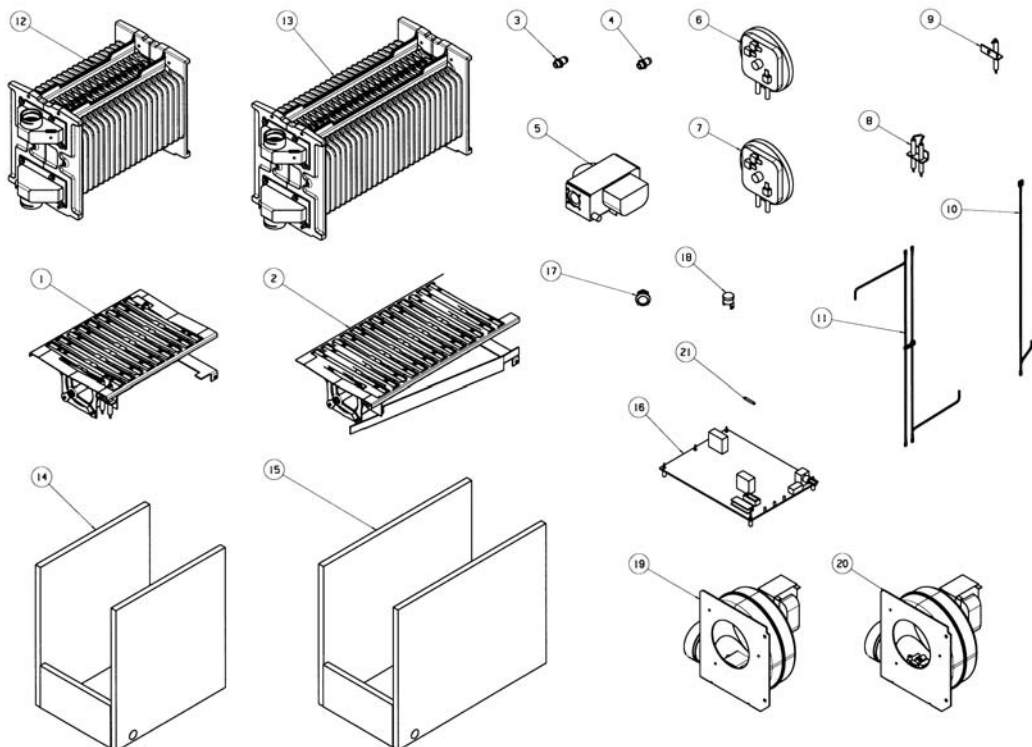
	9/14CBi	14/19CBi	19/24CBi
LPG — NG Kit No.	7 716 192 269	7 716 192 279	7 716 192 271
Burner Injector	8 716 157 116 (3.4mm)	8 716 103 168 (3.8mm)	8 716 157 115 (4.3mm)
Injector Washer	8 716 101 994	8 716 101 994	8 716 101 994
Burner Blade Assembly	8 716 142 654	8 716 142 653	8 716 142 653

**Table 10. Conversion from NG — LPG**

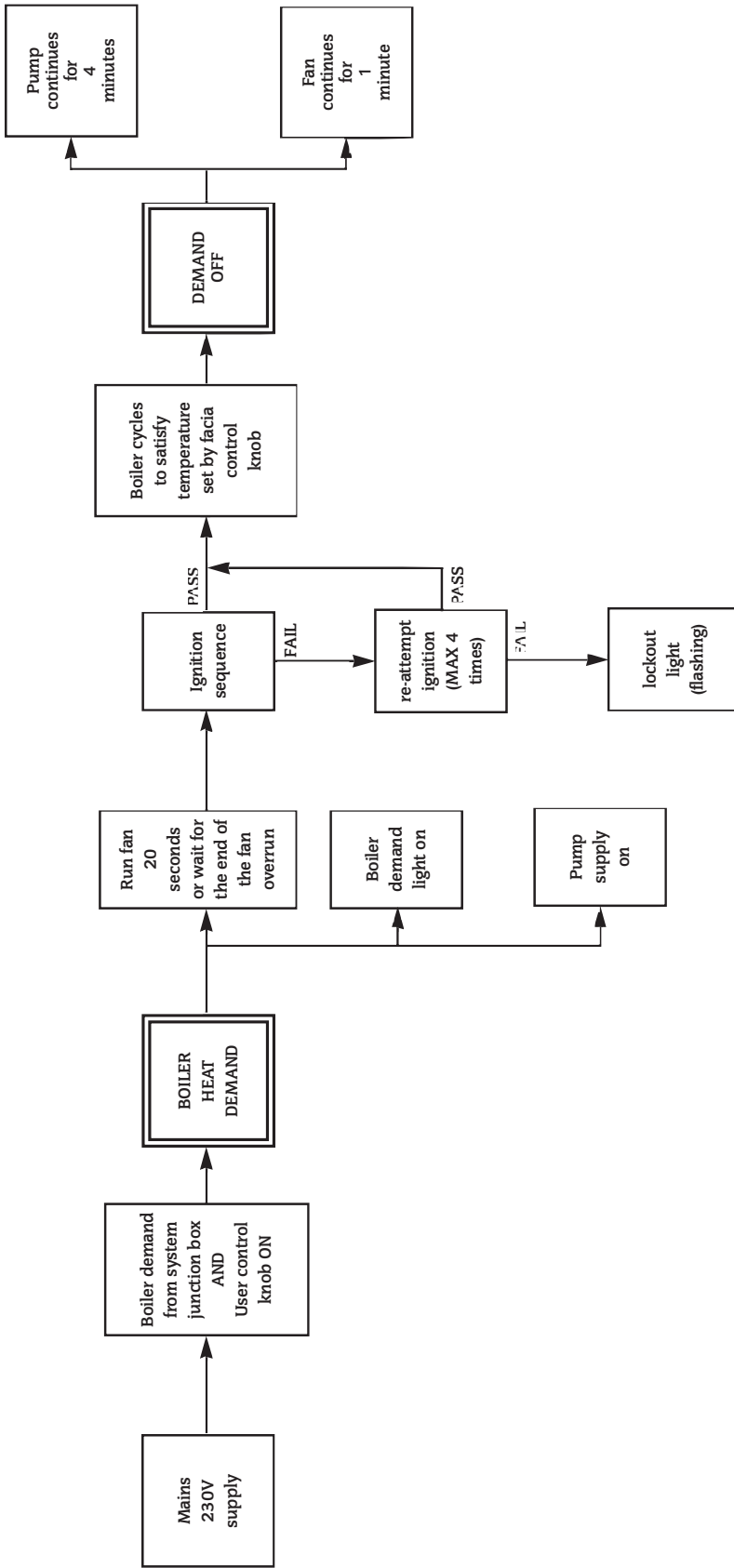
	9/14CBi	14/19CBi	19/24CBi
NG — LPG Kit No.	7 716 192 270	7 716 192 277	7 716 192 272
Burner Injector	8 716 102 407 (2.1mm)	8 716 103 169 (2.5mm)	8 716 102 411 (2.7mm)
Injector Washer	8 716 101 994	8 716 101 994	8 716 101 994
Burner Blade Assembly	8 716 102 408	8 716 102 412	8 716 102 412
LPG Label	ZK LAB 147	ZK LAB 417	ZK LAB 417

## 17. Short Parts List

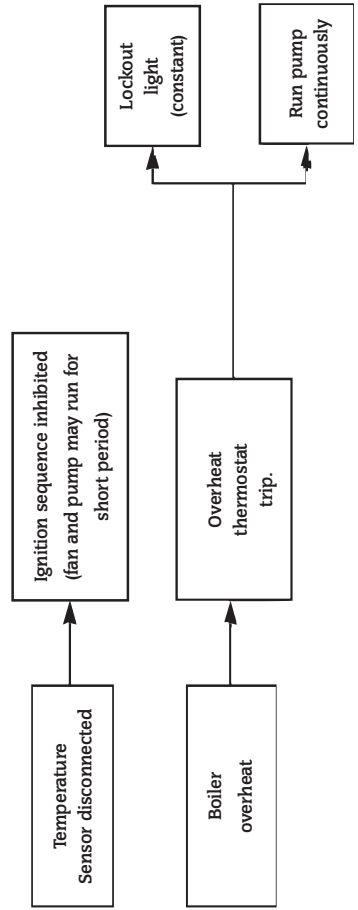
Key No.	G.C. No.	Part	Manufacturer's Reference	Qty	WHS Part No.
1	E60-473	Burner Assembly NG 9/14CBi		1	8 716 121 773 0
		Burner Assembly LPG 9/14CBi		1	8 716 103 210 0
2	E60-474	Burner Assembly NG 14/19, 19/24CBi		1	8 716 121 767 0
		Burner Assembly LPG 14/19, 19/24CBi		1	8 716 103 211 0
3	E60-475	Injector Burner 3.4mm NG 9/14CBi		1	8 716 157 116 0
		Injector Burner 2.1mm LPG 9/14CBi		1	8 716 102 407 0
		Injector Burner 3.8mm NG 14/19CBi		1	8 716 103 168 0
		Injector Burner 2.5mm LPG 14/19CBi		1	8 716 103 169 0
4	E60-476	Injector Burner 4.3mm NG 19/24CBi		1	8 716 157 115 0
		Injector Burner 2.7mm LPG 19/24CBi		1	8 716 102 411 0
5	E60-477	Gas Valve NG		1	8 716 156 769 0
6	E60-478	Air Pressure Switch 9/14, 14/19CBi		1	8 716 146 165 0
7	E60-479	Air Pressure Switch 19/24CBi		1	8 716 146 163 0
8	E60-480	Spark Electrode Assembly		1	8 716 142 140 0
9	E60-481	Sensor Electrode Assembly		1	8 716 142 139 0
10	E60-482	Spark Electrode Lead		1	8 716 121 805 0
11	E60-483	Sensor Electrode Lead		1	8 716 142 137 0
12	E60-484	Heat Exchanger Assembly 9/14CBi		1	8 716 121 699 0
13	E60-485	Heat Exchanger Assembly 14/19, 19/24CBi		1	8 716 121 700 0
14	E60-486	Insulation Kit 9/14CBi		1	7 716 101 854 0
15	E60-487	Insulation Kit 14/19, 19/24CBi		1	7 716 101 796 0
16	E60-492	Control Board PCB		1	8 716 146 332 0
17	E60-493	Overheat Thermostat		1	8 716 142 399 0
18	375 696	Primary/Domestic Thermister Sensor Kit		1	8 716 142 302 0
19	E60-498	Fan Assembly 9/14CBi		1	8 716 104 581 0
20	E60-499	Fan Assembly 14/19, 19/24CBi		1	8 716 104 582 0
21	E60-500	Fuse 4A Fast blow 20 X 5mm		10	8 716 156 008 0
22	E60-503	O-Ring Kit HT/Exchanger		1	8 716 101 797 0
23	E60-504	Gas Section Sealing Kit		1	8 716 101 798 0



# 18. Operational Flow Diagram



## Protection Systems



## 19. Fault Finding

**NOTE:** This fault finding information is for guidance only. Worcester, Bosch Group cannot be held responsible for costs incurred by persons not deemed to be competent.

The electronic control for this boiler incorporates three lights: Boiler demand, flame on and lockout. These form the basis for this fault finding guide.

To use this guide, select box below which represents the light situation during your fault, then refer to the appropriate section. This guide assumes a component failure has occurred following a period of normal running. It is not intended to solve installation errors.

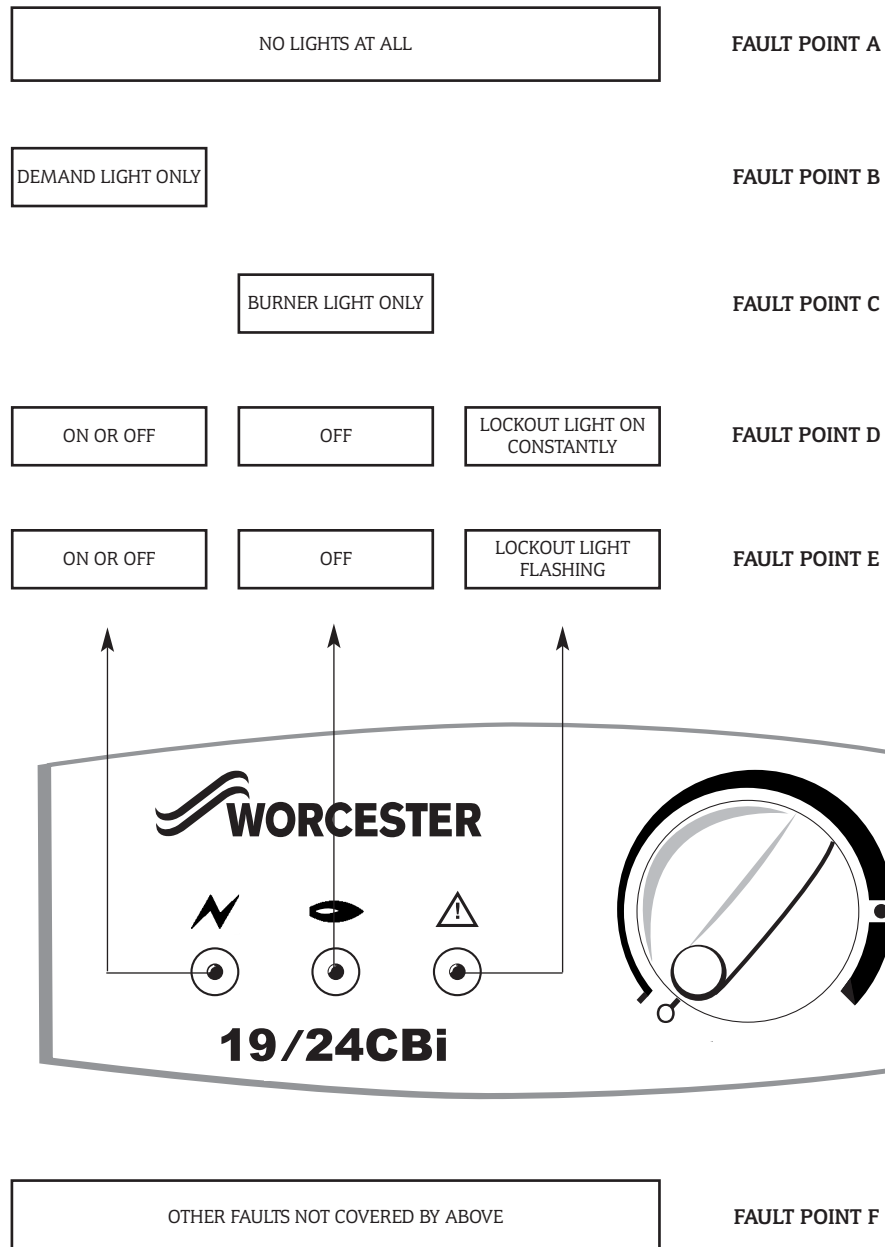
### PRELIMINARY CHECKS

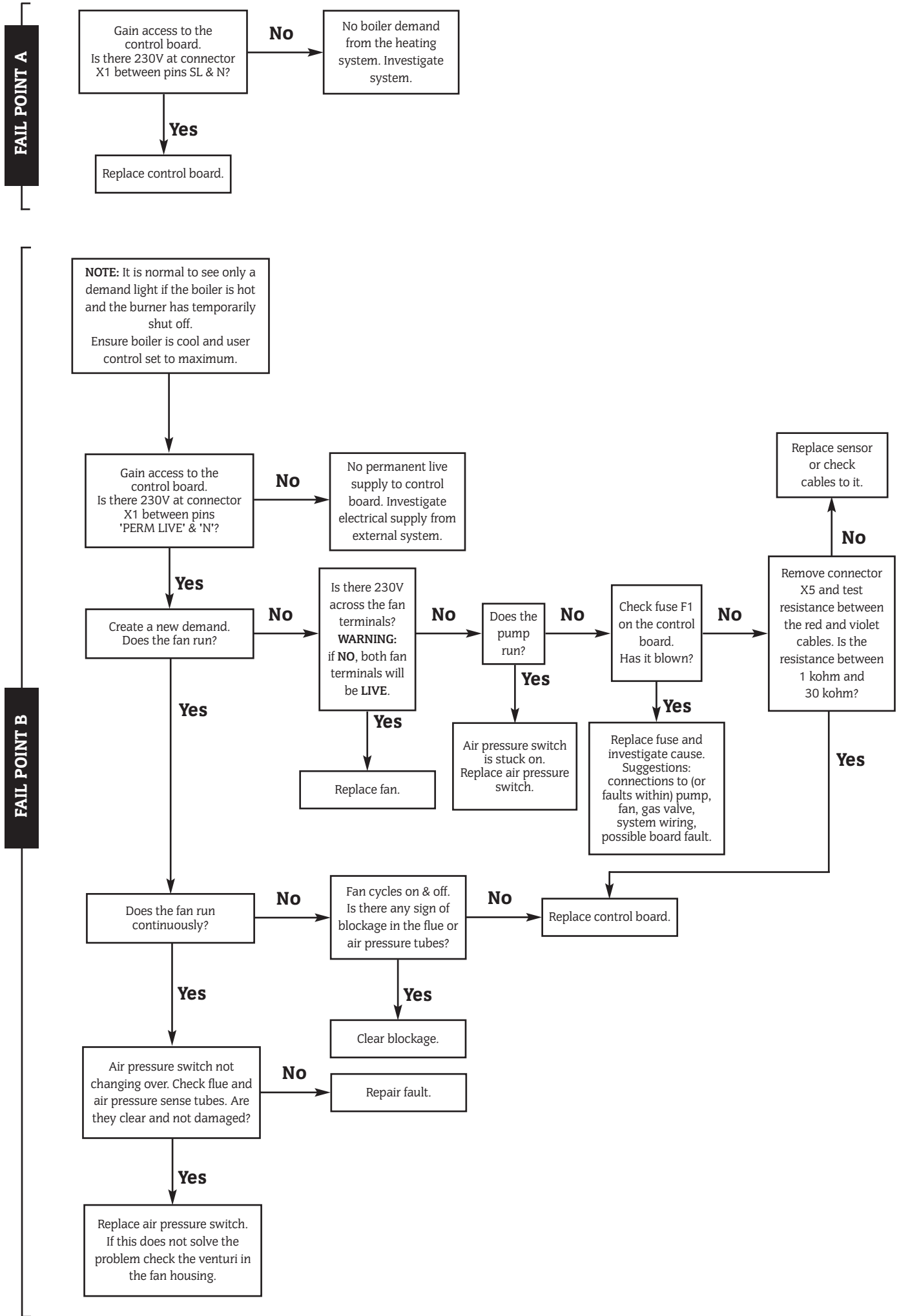
Preliminary electrical system checks are the first electrical checks to be carried out during a fault-finding procedure. On completion of the Service/Fault-finding task which has required the breaking and remaking of electrical connections, check (a) EARTH CONTINUITY, (b) SHORT CIRCUIT CHECK, (c) POLARITY and (d) RESISTANCE TO EARTH.

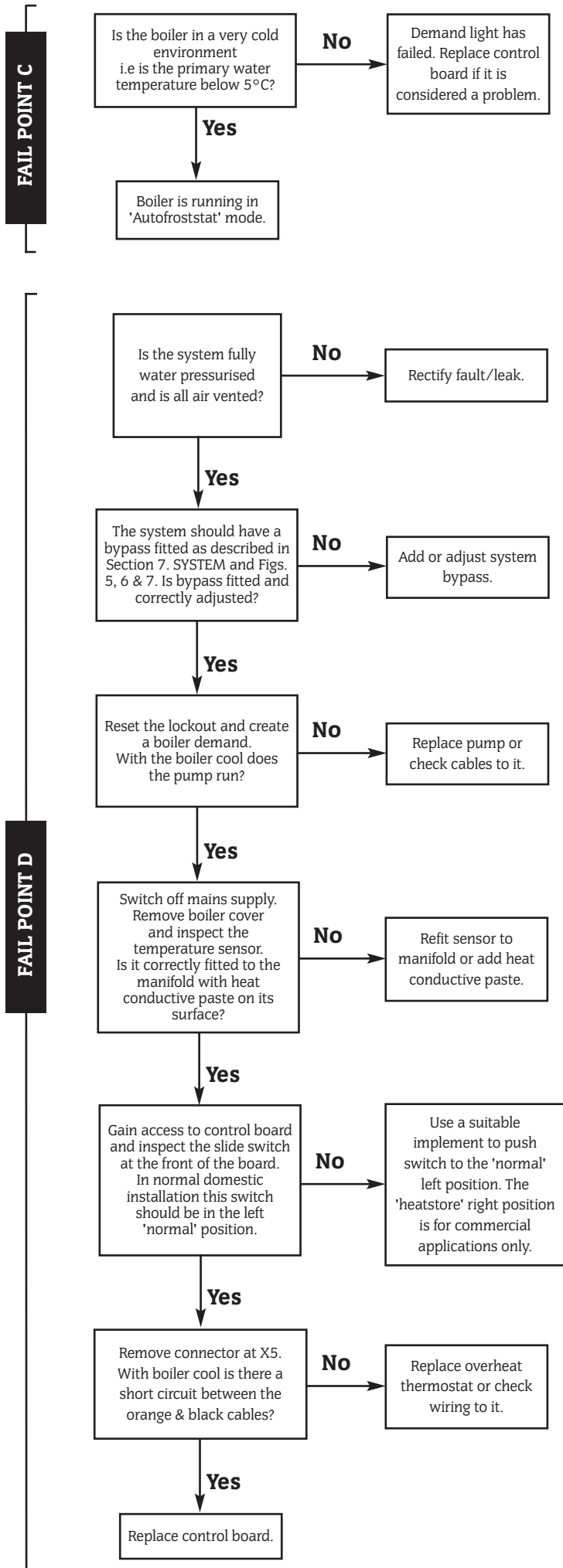
**WARNING:** In addition to the controls, the overheat thermostat and fan are connected directly to the permanent live supply. Under all circumstances remove the permanent live supply before touching these parts.

### LIGHT SITUATION DURING FAULT

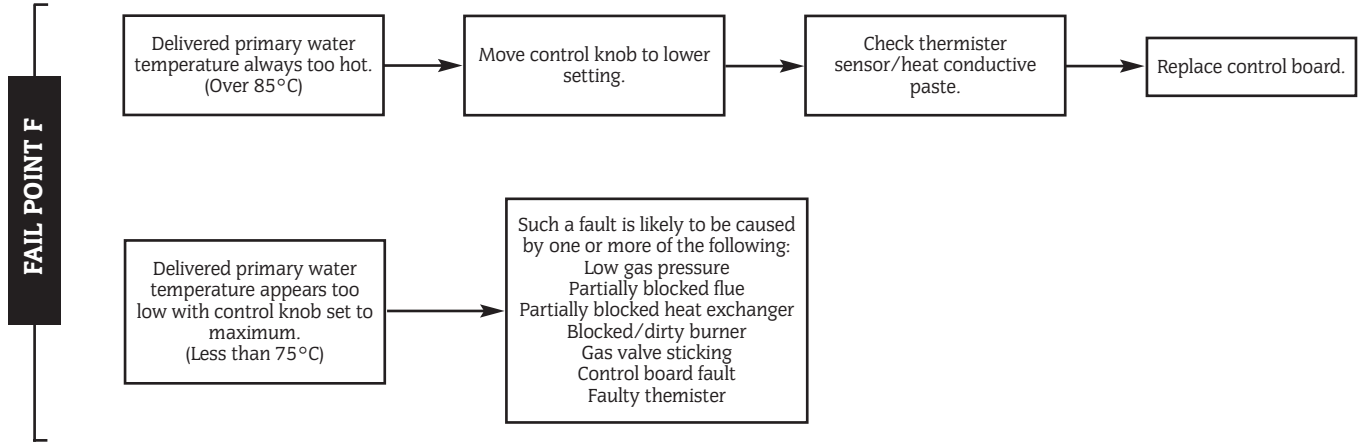
WITH A SYSTEM BOILER DEMAND AND USER CONTROL SET TO MAXIMUM:















# GAS BOILER COMMISSIONING CHECKLIST

BOILER SERIAL No. \_\_\_\_\_ NOTIFICATION No. \_\_\_\_\_

**CONTROLS** To comply with the Building Regulations, each section must have a tick in one or other of the boxes

TIME & TEMPERATURE CONTROL TO HEATING	ROOM T/STAT & PROGRAMMER/TIMER <input type="checkbox"/>	PROGRAMMABLE ROOMSTAT <input type="checkbox"/>
TIME & TEMPERATURE CONTROL TO HOT WATER	CYLINDER T/STAT & PROGRAMMER/TIMER <input type="checkbox"/>	COMBI BOILER <input type="checkbox"/>
HEATING ZONE VALVES	FITTED <input type="checkbox"/>	NOT REQUIRED <input type="checkbox"/>
HOT WATER ZONE VALVES	FITTED <input type="checkbox"/>	NOT REQUIRED <input type="checkbox"/>
THERMOSTATIC RADIATOR VALVES	FITTED <input type="checkbox"/>	
AUTOMATIC BYPASS TO SYSTEM	FITTED <input type="checkbox"/>	NOT REQUIRED <input type="checkbox"/>

FOR ALL BOILERS CONFIRM THE FOLLOWING

THE SYSTEM HAS BEEN FLUSHED IN ACCORDANCE WITH THE BOILER MANUFACTURER[S] INSTRUCTIONS?

THE SYSTEM CLEANER USED \_\_\_\_\_

THE INHIBITOR USED \_\_\_\_\_

FOR THE CENTRAL HEATING MODE, MEASURE & RECORD

GAS RATE	<input type="text"/>	m <sup>3</sup> /hr	<input type="text"/>	tf <sup>3</sup> /hr
BURNER OPERATING PRESSURE (IF APPLICABLE)	<input type="checkbox"/>	N/A	<input type="text"/>	mbar
CENTRAL HEATING FLOW TEMPERATURE			<input type="text"/>	°C
CENTRAL HEATING RETURN TEMPERATURE			<input type="text"/>	°C

FOR COMBINATION BOILERS ONLY

HAS A WATER SCALE REDUCER BEEN FITTED? YES  NO

WHAT TYPE OF SCALE REDUCER HAS BEEN FITTED? \_\_\_\_\_

FOR THE DOMESTIC HOT WATER MODE, MEASURE & RECORD

GAS RATE	<input type="text"/>	m <sup>3</sup> /hr	<input type="text"/>	tf <sup>3</sup> /hr
MAXIMUM BURNER OPERATING PRESSURE (IF APPLICABLE)	<input type="checkbox"/>	N/A	<input type="text"/>	mbar
COLD WATER INLET TEMPERATURE			<input type="text"/>	°C
HOT WATER OUTLET TEMPERATURE			<input type="text"/>	°C
WATER FLOW RATE			<input type="text"/>	lts/min

FOR CONDENSING BOILERS ONLY CONFIRM THE FOLLOWING

THE CONDENSATE DRAIN HAS BEEN INSTALLED IN ACCORDANCE WITH THE MANUFACTURER[S] INSTRUCTIONS? YES

FOR ALL INSTALLATIONS CONFIRM THE FOLLOWING

THE HEATING AND HOT WATER SYSTEM COMPLIES WITH CURRENT BUILDING REGULATIONS

THE APPLIANCE AND ASSOCIATED EQUIPMENT HAS BEEN INSTALLED AND COMMISSIONED IN ACCORDANCE WITH THE MANUFACTURER[S] INSTRUCTIONS

IF REQUIRED BY THE MANUFACTURER, HAVE YOU RECORDED A CO/CO<sub>2</sub> RATIO READING? N/A  YES  CO/CO<sub>2</sub> RATIO

THE OPERATION OF THE APPLIANCE AND SYSTEM CONTROLS HAVE BEEN DEMONSTRATED TO THE CUSTOMER

THE MANUFACTURER[S] LITERATURE HAS BEEN LEFT WITH THE CUSTOMER

COMMISSIONING ENG[S] NAME PRINT \_\_\_\_\_ CORGI ID No. \_\_\_\_\_

SIGN \_\_\_\_\_ DATE \_\_\_\_\_

# SERVICE INTERVAL RECORD

It is recommended that your heating system is serviced regularly and that you complete the appropriate Service Interval Record Below.

Service Provider. Before completing the appropriate Service Interval Record below, please ensure you have carried out the service as described in the boiler manufacturer's instructions. Always use the manufacturer's specified spare part when replacing all controls

## SERVICE 1 DATE

ENGINEER NAME \_\_\_\_\_  
COMPANY NAME \_\_\_\_\_  
TEL No. \_\_\_\_\_  
CORGI ID CARD SERIAL No. \_\_\_\_\_  
COMMENTS \_\_\_\_\_  
SIGNATURE \_\_\_\_\_

## SERVICE 2 DATE

ENGINEER NAME \_\_\_\_\_  
COMPANY NAME \_\_\_\_\_  
TEL No. \_\_\_\_\_  
CORGI ID CARD SERIAL No. \_\_\_\_\_  
COMMENTS \_\_\_\_\_  
SIGNATURE \_\_\_\_\_

## SERVICE 3 DATE

ENGINEER NAME \_\_\_\_\_  
COMPANY NAME \_\_\_\_\_  
TEL No. \_\_\_\_\_  
CORGI ID CARD SERIAL No. \_\_\_\_\_  
COMMENTS \_\_\_\_\_  
SIGNATURE \_\_\_\_\_

## SERVICE 4 DATE

ENGINEER NAME \_\_\_\_\_  
COMPANY NAME \_\_\_\_\_  
TEL No. \_\_\_\_\_  
CORGI ID CARD SERIAL No. \_\_\_\_\_  
COMMENTS \_\_\_\_\_  
SIGNATURE \_\_\_\_\_

## SERVICE 5 DATE

ENGINEER NAME \_\_\_\_\_  
COMPANY NAME \_\_\_\_\_  
TEL No. \_\_\_\_\_  
CORGI ID CARD SERIAL No. \_\_\_\_\_  
COMMENTS \_\_\_\_\_  
SIGNATURE \_\_\_\_\_

## SERVICE 6 DATE

ENGINEER NAME \_\_\_\_\_  
COMPANY NAME \_\_\_\_\_  
TEL No. \_\_\_\_\_  
CORGI ID CARD SERIAL No. \_\_\_\_\_  
COMMENTS \_\_\_\_\_  
SIGNATURE \_\_\_\_\_

## SERVICE 7 DATE

ENGINEER NAME \_\_\_\_\_  
COMPANY NAME \_\_\_\_\_  
TEL No. \_\_\_\_\_  
CORGI ID CARD SERIAL No. \_\_\_\_\_  
COMMENTS \_\_\_\_\_  
SIGNATURE \_\_\_\_\_

## SERVICE 8 DATE

ENGINEER NAME \_\_\_\_\_  
COMPANY NAME \_\_\_\_\_  
TEL No. \_\_\_\_\_  
CORGI ID CARD SERIAL No. \_\_\_\_\_  
COMMENTS \_\_\_\_\_  
SIGNATURE \_\_\_\_\_

## SERVICE 9 DATE

ENGINEER NAME \_\_\_\_\_  
COMPANY NAME \_\_\_\_\_  
TEL No. \_\_\_\_\_  
CORGI ID CARD SERIAL No. \_\_\_\_\_  
COMMENTS \_\_\_\_\_  
SIGNATURE \_\_\_\_\_

## SERVICE 10 DATE

ENGINEER NAME \_\_\_\_\_  
COMPANY NAME \_\_\_\_\_  
TEL No. \_\_\_\_\_  
CORGI ID CARD SERIAL No. \_\_\_\_\_  
COMMENTS \_\_\_\_\_  
SIGNATURE \_\_\_\_\_



This manual is to be used in conjunction with the variant part number of the bar code below:



**8716103192**

[www.worcester-bosch.co.uk](http://www.worcester-bosch.co.uk)



Worcester, Bosch Group, Cotswold Way, Warndon, Worcester WR4 9SW.

Telephone: 01905 754624. Fax: 01905 753130.

Technical Helpline 08705 266241.

Worcester, Bosch Group is a trading name of BBT Thermotechnology UK Limited.

---

This booklet is accurate at the date of printing but will be superseded and should be disregarded if specifications and/or appearances are changed in the interests of continued improvement.

All goods sold are subject to our official Conditions of Sale, a copy of which may be obtained on application.

**PUBLICATION 8 716 115 015a (02/08)**