

THIS DOCUMENT HAS BEEN PROVIDED BY



PLEASE VISIT [WWW.HEATINGSPPARES247.COM](http://WWW.HEATINGSPPARES247.COM) FOR FURTHER INFORMATION AND GENUINE PARTS & SPARES AT LOW PRICES

**Vokèra**  
heating for life

# Unica HE

## High efficiency combi boiler

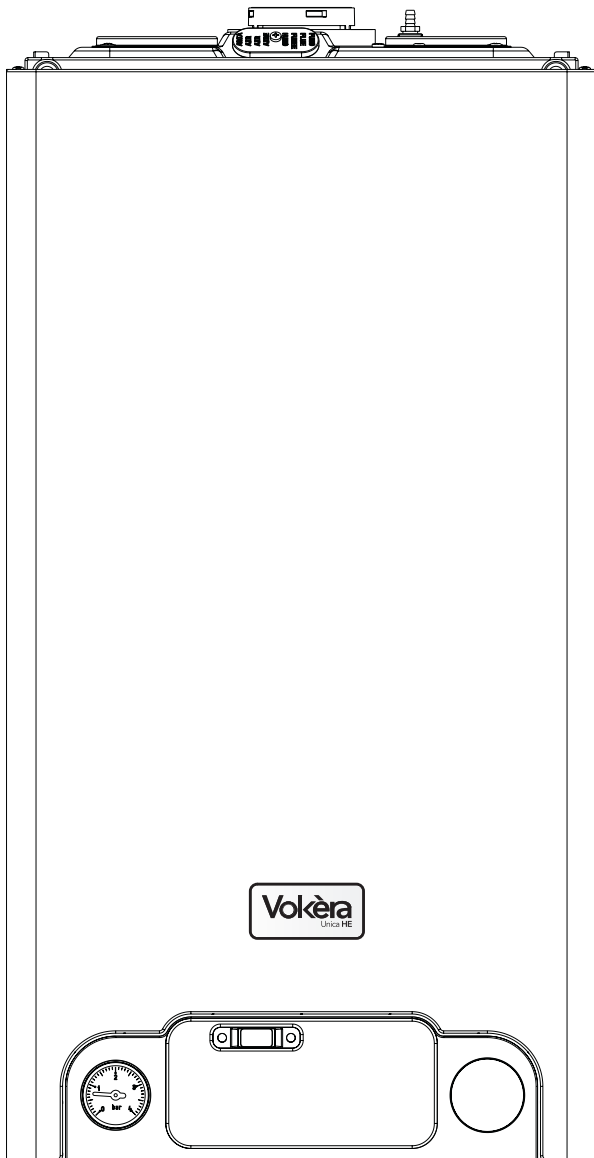

### Users Instructions



THESE INSTRUCTIONS  
TO BE RETAINED  
BY USER



Vokèra is a licensed member of the Benchmark scheme which aims to improve the standards of installation and commissioning of domestic hot water systems in the UK.

## Contents

Introduction	Page
Dear customer	2
Do's and don't's	2

Things you should know	Page
1.1 Gas appliances	3
1.2 Electrical supply	3
1.3 Guarantee registration card	3
1.4 Appliance log book (UK only)	3
1.5 How does it work?	3
1.6 Dimensions	3
1.7 Clearances required	3
1.8 Frost protection system	3
1.9 Status indicators	3
1.10 Digital display	4

Getting started	Page
2.1 Before switching on	5
2.2 Appliance controls	5
2.3 Lighting the boiler	5
2.4 Adjusting the CH temperature	5
2.5 Adjusting the DHW temperature	5

How to...	Page
3.1 Top-up the system	6
3.2 Reset the appliance	6
3.3 Shut down the system for short periods	6
3.4 Shut down the system for long periods	6
3.5 Care for the appliance	6

What if...	Page
4.1 I suspect a gas leak	7
4.2 I have to frequently to top-up the system	7
4.3 The RED fault light is on	7
4.4 The appliance is due its annual service	7
4.5 I need to call an engineer	7

Setting the Vokera...	Page
5.1 Mechanical clock	7

---

## INTRODUCTION

---

### Dear Customer

Your Vokera Mynute HE boiler has been designed to meet and exceed the very latest standards in gas central heating technology, and if cared for, will give years of reliable use and efficiency.

Please therefore take some time to read these instructions carefully.

### Do's and Don't's

- **Do** ensure that the system pressure is periodically checked
- **Do** ensure that you know how to isolate the appliance in an emergency
- **Do** ensure that you are familiar with the appliance controls
- **Do** ensure that your installer has completed the appliance log book section
- **Do not** attempt to remove the appliance casing or gain internal access
- **Do not** hang clothes etc. over the appliance
- **Do not** forget to have the appliance serviced annually.

This booklet is an integral part of the appliance. It is therefore necessary to ensure that the booklet is handed to the person responsible for the property in which the appliance is located/installed. A replacement copy can be obtained from Vokera customer services.

## THINGS YOU SHOULD KNOW

### 1.1 GAS APPLIANCES

#### Gas Safety (Installations and Use) Regulations (UK).

In the interests of your safety and that of others it is a legal requirement that all gas appliances are installed and correctly maintained by a competent person and in accordance with the latest regulations.

### 1.2 ELECTRICAL SUPPLY

Please ensure that this appliance has been properly connected to the electrical supply by means of a double pole isolator or un-switched socket, and that the correct size of fuse (3 AMP) has been fitted.

**Warning: this appliance must be earthed!**

### 1.3 GUARANTEE REGISTRATION CARD

Please take the time to fill out your guarantee registration card. The completed warranty card should be posted within 30 days of installation.

### 1.4 APPLIANCE LOG BOOK (UK only)

A logbook section can be found at the rear of the appliance installation booklet. This important document must be completed during the installation/commissioning of your boiler. All CORGI registered installers carry a CORGI ID card, and have a registration number. These details should be recorded in the Benchmark logbook section within the installation booklet. You can check your installers details by calling CORGI direct on 01256 372300. Failure to install and commission the appliance in accordance with the manufacturers instructions may invalidate the warranty. This does not affect your statutory rights.

### 1.5 HOW DOES IT WORK?

Your Unica HE boiler supplies heated water to your radiators and hot water to your hot water taps.

The central heating is controlled via a time clock and any thermostats that your installer may have fitted. The boiler will light when it receives a request from the time clock via any thermostat that may be installed, or whenever a hot water outlet (tap) is opened.

Your Unica HE boiler lights electronically and does not have a pilot light.

In the unlikely event of a fault developing with your boiler, the supply of gas to the burner will be terminated automatically.

### 1.6 DIMENSIONS

<b>Unica 28HE</b>	
HEIGHT	780mm
WIDTH	400mm
DEPTH	358mm
<b>Unica 32/36HE</b>	
HEIGHT	780mm
WIDTH	450mm
DEPTH	358mm

### 1.7 CLEARANCES REQUIRED

ABOVE	150 mm
BELOW	150 mm
LEFT SIDE	50 mm
RIGHT SIDE	12mm
FRONT	600 mm

### 1.8 FROST PROTECTION SYSTEM

The Unica HE is equipped with a built-in frost protection system, this enables the boiler to override the time controls – even if switched off – and operate the burner and/or pump, should the temperature drop below 6°C for the main and below 4°C for the DHW line. In particular the burner will be in ON status until the main temperature reaches 35°C for CH appliance and 55°C for DHW appliance.

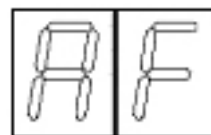

Please note that the frost protection system is designed to protect the appliance only, should frost protection be required for the heating system, additional controls may be required.

When the frost protection system has been activated, 'AF' is displayed on the appliance LED display (see below).

#### NOTE

The frost protection system is reliant on the appliance having a permanent electrical supply, and being in a non-fault condition.

### 1.9 APPLIANCE STATUS INDICATORS

Your boiler is equipped with 2 status LED indicators, the Green LED indicates that the flame is present, whilst the Red LED indicates the appliance has detected a fault.

**1.10 DIGITAL DISPLAY**

The 2-digit digital display will normally show the current working (outlet) temperature of the boiler, however in certain circumstances a fault code or specific characters will be displayed to indicate that the appliance is performing a specific function.

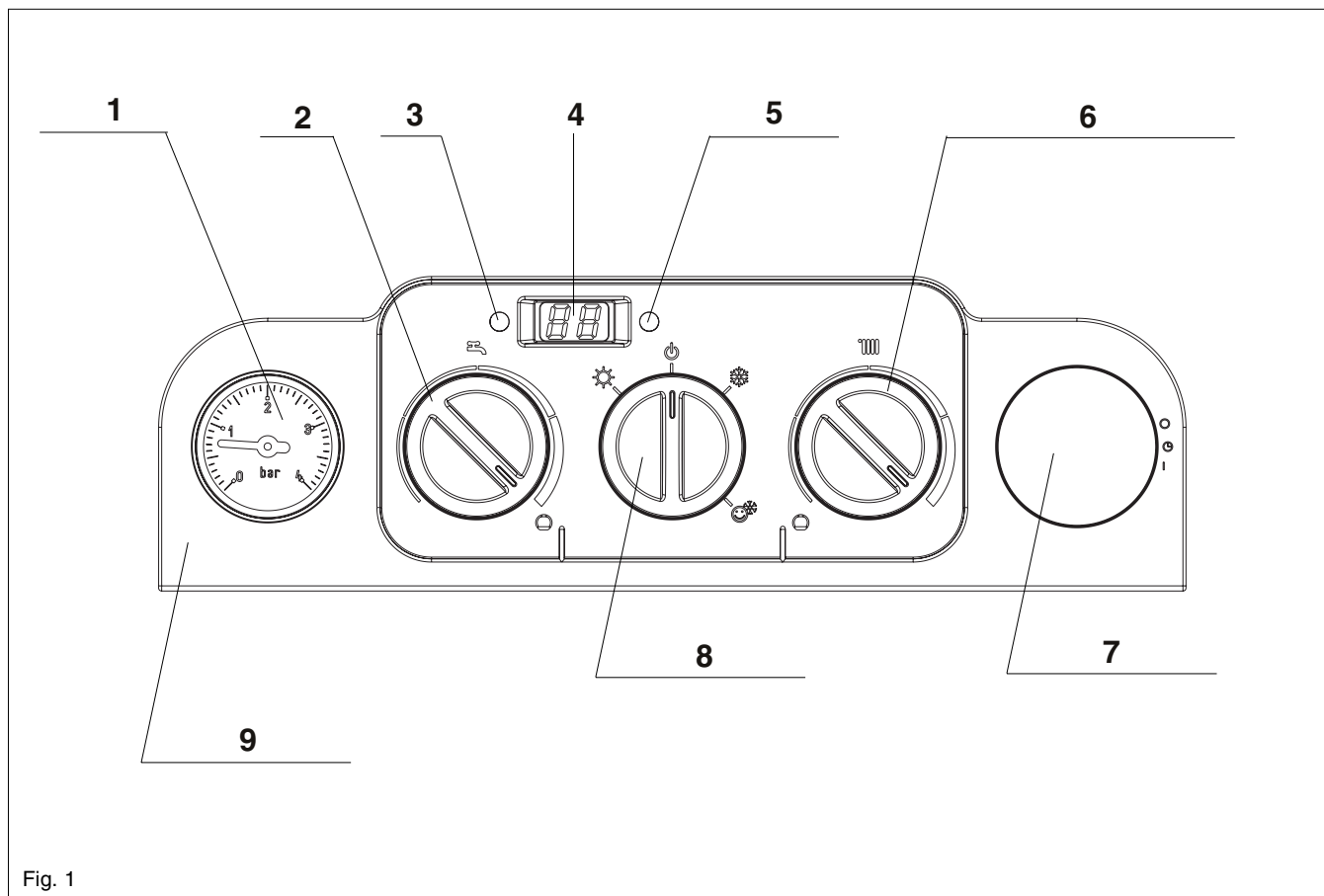

Fig. 1

- 1. Pressure gauge
- 2. Hot water temperature selector
- 3. Green LED indicator
- 4. 2-digit display
- 5. Red LED indicator
- 6. Heating temperature selector
- 7. Clock (if fitted)
- 8. Mode selector switch
- 9. Front cover

## GETTING STARTED

### 2.1 BEFORE SWITCHING ON

Before switching the appliance on please familiarise yourself with:

- how to isolate the appliance from the gas, water, and electricity supplies;
- how to check and top-up – if necessary – the system water pressure;
- the time clock or programmer;
- any external thermostats and their functions;
- the appliance controls.





### 2.2 APPLIANCE CONTROLS (see fig. 1)

The appliance controls are situated on the lower front of the appliance. The appliance controls include:

- pressure gauge;
- appliance mode selector;
- temperature selector;
- 2-digit LED display;
- burner ON mode (green);
- fault indicator (red);
- optional integral time clock/programmer (if fitted).

The **pressure gauge** shows the current pressure of your heating system, the gauge should be set between 1 and 1.5 BAR. When the appliance is operating the gauge may rise or fall slightly, this is quite normal. The minimum permissible level for the safe and efficient operation of the appliance is 0.5 BAR. Should the pressure fall below 0.5 BAR, the boiler may lockout.

The **appliance mode selector** is used to switch the boiler to the various operating modes:

- OFF/RESET “”
- DHW MODE “”
- CH MODE “”
- CH with PREHEATING MODE “”

#### NOTE

The appliance frost protection is active in all of the above modes.

The **temperature selectors** can be used to vary the temperature of the water that circulates around your radiators and the water that flows from your hot water taps. The temperature range is adjustable between 40°C and 80°C for the central heating, and between 35°C and 60°C for the hot water. Moreover if floor heating mode is selected (by using the relative jumper), the temperature range for CH mode can be modified between 20°C and 45°C.

The **2-digit LED display normally** shows the operating temperature of the appliance, however it can also display additional characters or flashing numbers to signify specific operating modes or fault codes.

When the **status indicator (Green) is lit** it indicates that the flame is present and the burner is ON.

When the **fault indicator (Red) is lit** it indicates that the appliance has identified a possible fault and performed a safety lockout.

The **integral time clock (when fitted)** can be used to switch the heating on and off at pre-determined intervals. The **integral time clock or programmer (when fitted)** can be used to switch the heating and/or hot water on and off at pre-determined intervals.

### 2.3 LIGHTING THE BOILER

**Ensure the gas and electrical supply to the boiler are turned on.**

Turn the mode selector switch to the **ON** position. When there is a request for heating or hot water via the time clock or programmer, the boiler will begin an ignition sequence. When the appliance reaches the set temperature, the burner will go off for a minimum period of approximately 3 minutes.

When the programmer/time clock or external thermostats heating request has been satisfied, the appliance will switch off automatically.

### 2.4 ADJUSTING THE HEATING TEMPERATURE

Rotate the temperature selector – clockwise to increase, counter-clockwise to decrease – to the desired temperature setting. The temperature can be set from a minimum of 40°C to a maximum of 80°C (if standard CH mode is selected).

### 2.5 ADJUSTING THE HOT WATER TEMPERATURE

Rotate the temperature selector – clockwise to increase, counter-clockwise to decrease – to the desired temperature setting. The temperature can be set from a minimum of 35°C to a maximum of 60°C. If the temperature at the outlet is still not sufficiently hot enough, it may be necessary to reduce the flow of water at the hot water outlet (tap).

#### NOTE

If the appliance fails to ignite during the ignition sequence, it will enter a lockout condition. Should this occur, please allow a period of at least two minutes before re-setting the appliance.

**HOWTO...**

**3.1 HOW TO TOP-UP THE SYSTEM PRESSURE (fig. 2 & 3)**

The system pressure must be checked periodically to ensure the correct operation of the boiler. The needle on the gauge should be reading between 1 and 1.5 BAR when the boiler is in an off position and has cooled to room temperature. If the pressure requires 'topping-up' use the following instructions as a guide.

- Locate the filling valve connections (usually beneath the boiler, see fig. 2).
- Attach the filling loop to both connections.
- Open the filling valve slowly until you hear water entering the system.
- Close the filling valve when the pressure gauge (on the boiler) reads between 1 and 1.5 BAR.
- Remove the filling loop from the connections.

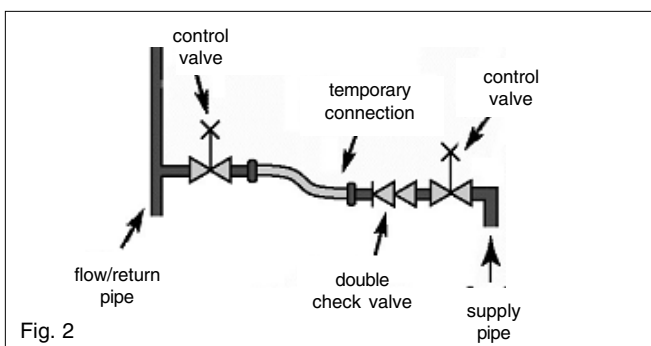

Fig. 2

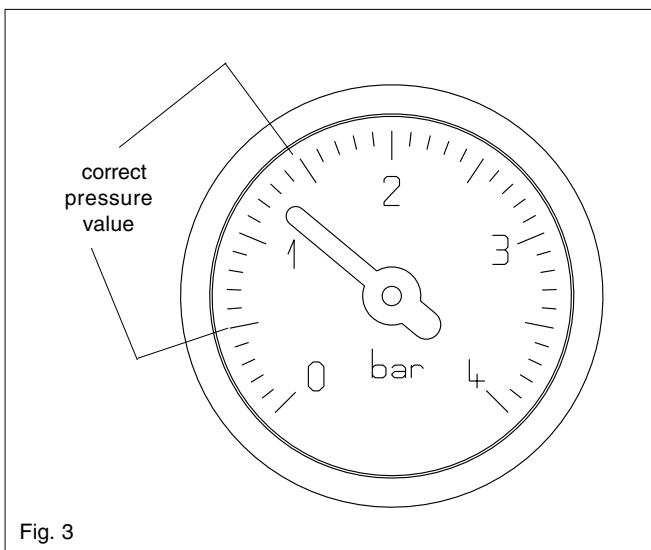

Fig. 3

**3.2 HOW TO RESET THE APPLIANCE**

When the red fault LED is illuminated, the appliance will require to be reset manually. Before resetting the boiler, check what action is required to be taken, using the information on the fault code table below. Allow a period of two minutes to elapse before rotate the mode selector knob across the OFF/RESET position.

**APPLIANCE FAULT CODES**

CODE	ACTION REQUIRED
AL10	Reset appliance. Call engineer if fault re-occurs
AL20	Reset appliance. Call engineer if fault re-occurs
AL21	Reset appliance. Call engineer if fault re-occurs
AL26	Reset appliance. Call engineer if fault re-occurs
AL28	Reset appliance. Call engineer if fault re-occurs
AL34	Reset appliance. Call engineer if fault re-occurs
AL40	Check system pressure and refill if necessary. Reset appliance. Call engineer if fault re-occurs
AL41	Check system pressure and refill if necessary. Call engineer if fault re-occurs
AL52	Call engineer
AL55	Call engineer
AL60	Reset appliance. Call engineer if fault re-occurs
AL71	Call engineer if fault re-occurs
AL73	Call engineer if fault re-occurs
AL74	Reset appliance. Call engineer if fault re-occurs
AL79	Reset appliance. Call engineer if fault re-occurs

**IMPORTANT**

If the appliance requires to be reset frequently, it may be indicative of a fault, please contact your installer or Vokera Customer Services for further advice.

**3.3 HOW TO SHUT DOWN THE SYSTEM FOR SHORT PERIODS**

The system and boiler can be shut down for short periods by simply turning the time clock to the off position. It is also advisable to turn off the main water supply to the house.

**3.4 HOW TO SHUT DOWN THE SYSTEM FOR LONG PERIODS**

If the house is to be left unoccupied for any length of time – especially during the winter – the system should be thoroughly drained of all water. The gas, water, and electricity supply to the house should also be turned off. For more detailed advice contact your installer.

**3.5 HOW TO CARE FOR THE APPLIANCE**

To clean the outer casing use only a clean damp cloth. Do not use any scourers or abrasive cleaners.

## WHAT IF...

### 4.1 WHAT IF I SUSPECT A GAS LEAK

If you suspect a gas leak, turn off the gas supply at the gas meter and contact your installer or local gas supplier. If you require further advice please contact your nearest Vokera office.

### 4.2 WHAT IF I HAVE FREQUENTLY TO TOP-UP THE SYSTEM

If the system regularly requires topping-up, it may be indicative of a leak. Please contact your installer and ask him to inspect the system.

### 4.3 WHAT IF THE RESET LIGHT IS ON

If the Red LED light is illuminated, it indicates that the boiler has failed to ignite or has detected a possible fault. When this happens the boiler automatically shuts down and requires to be reset manually (see 3.2).

### 4.4 WHAT IF THE APPLIANCE IS DUE ITS ANNUAL SERVICE

#### Advice for tenants only

Your landlord should arrange for servicing.

#### Advice for homeowners

Please contact Vokera Customer Service (**0870 333 0220 (UK) or 05655057 (ROI)**) if you would prefer a Vokera service engineer or agent to service your appliance. Alternatively your local CORGI registered engineer may be able to service the appliance for you.

### 4.5 WHAT IF I NEED TO CALL AN ENGINEER

If you think your boiler may have developed a fault, please contact your installer or Vokera Customer Services (**0870 333 0220 (UK) or 05655057 (ROI)**) have all your details to hand including full address and postcode, relevant contact numbers, and your completed appliance log book.

## SETTING THE VOKERA...

### 5.1 SETTING THE VOKERA MECHANICAL CLOCK

If your boiler has been installed with the Vokera mechanical clock, it can be used and adjusted as follows:

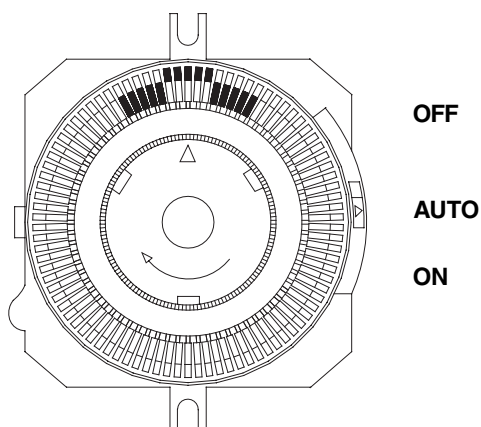

#### Setting the time

The time of day can be set by grasping the outer edge of the black dial and turning it in a clockwise direction until the correct time is in line with the white pointer.

#### Setting the “switching times”

The “**ON**” periods are set by sliding the black tappets, adjacent to the time periods required, to the outer edge of the dial. The tappets that remain at the centre of the dial will be the “**OFF**” periods.

The smallest switching time (ON or OFF) is 15 minutes.

To select “**AUTO**” mode move the selector switch in central position.

To select “**ON**” mode move the selector switch in the bottom position.

To select “**OFF**” mode move the selector switch in the upper position.



Cod. 10028636 - 28/06 - Ed. 2

**Registered address:**

Vokèra Ltd  
Borderlake House  
Unit 7 Riverside Industrial Estate  
London Colney  
Herts AL2 1HG

**enquiries@vokera.co.uk**

**www.vokera.co.uk**  
**www.vokera.ie**

**Sales, General Enquires**

**T 0844 391 099**  
**F 0844 391 0998**

Vokèra Ireland  
West Court, Callan  
Co Kilkenny  
**T 056 7755057**  
**F 056 7755060**

Vokèra Limited reserve the right to change  
specification without prior notice  
Consumers statutory rights are not affected.

A Riello Group Company.  
Company Reg No: 1047779