

THIS DOCUMENT HAS BEEN PROVIDED BY



PLEASE VISIT WWW.HEATINGSPPARES247.COM FOR FURTHER INFORMATION AND GENUINE PARTS & SPARES AT LOW PRICES

Vokèra
heating for life

Linea HE

High efficiency combi boiler

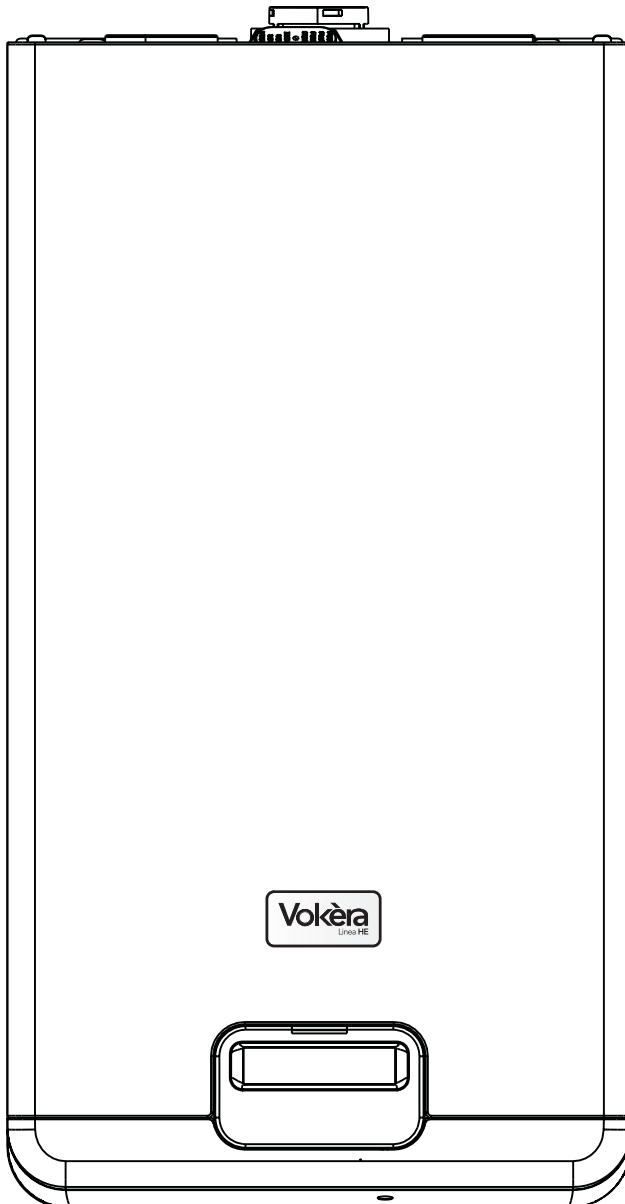

Users Instructions



**THESE INSTRUCTIONS
TO BE RETAINED
BY USER**



Vokèra is a licensed member of the Benchmark scheme which aims to improve the standards of installation and commissioning of domestic hot water systems in the UK.

Contents

Introduction	Page
Dear customer	2
Do's and don't's	2

Things you should know	Page
1.1 Gas appliances	4
1.2 Electrical supply	4
1.3 Guarantee registration card	4
1.4 Benchmark log book	4
1.5 How does it work?	4
1.6 Dimensions	4
1.7 Clearances required	4
1.8 Frost protection system	4
1.9 Additional controls	4

Getting started	Page
2.1 Before switching on	5
2.2 Appliance controls	5
2.3 Lighting the boiler	5
2.4 Adjusting the operating temperatures	6
2.5 Digital display	6
2.6 Fault code table	6
2.7 Information mode	7

How to...	Page
3.1 Top-up the system pressure	8
3.2 Reset the appliance	8
3.3 Shut down the system for short periods	8
3.4 Shut down the system for long periods	8
3.5 Care for the appliance	8
3.6 Regulate the hot water temperature	8

What if...	Page
4.1 I suspect a gas leak	9
4.2 I have to frequently to top-up the system	9
4.3 The reset light is on	9
4.4 The appliance is due its annual service	9
4.5 I need to call an engineer	9

INTRODUCTION

Dear Customer

Your Linea HE boiler has been designed to meet and exceed the very latest standards in gas central heating technology, and if cared for, will give years of reliable use and efficiency.

Please therefore take some time to read these instructions carefully.

Do's and Don't's

- **Do** ensure that the system pressure is periodically checked
- **Do** ensure that you know how to isolate the appliance in an emergency
- **Do** ensure that you are familiar with the appliance controls
- **Do** ensure that your installer has completed the appliance log book
- **Do not** attempt to remove the appliance casing or gain internal access
- **Do not** hang clothes etc. over the appliance
- **Do not** forget to have the appliance serviced annually.

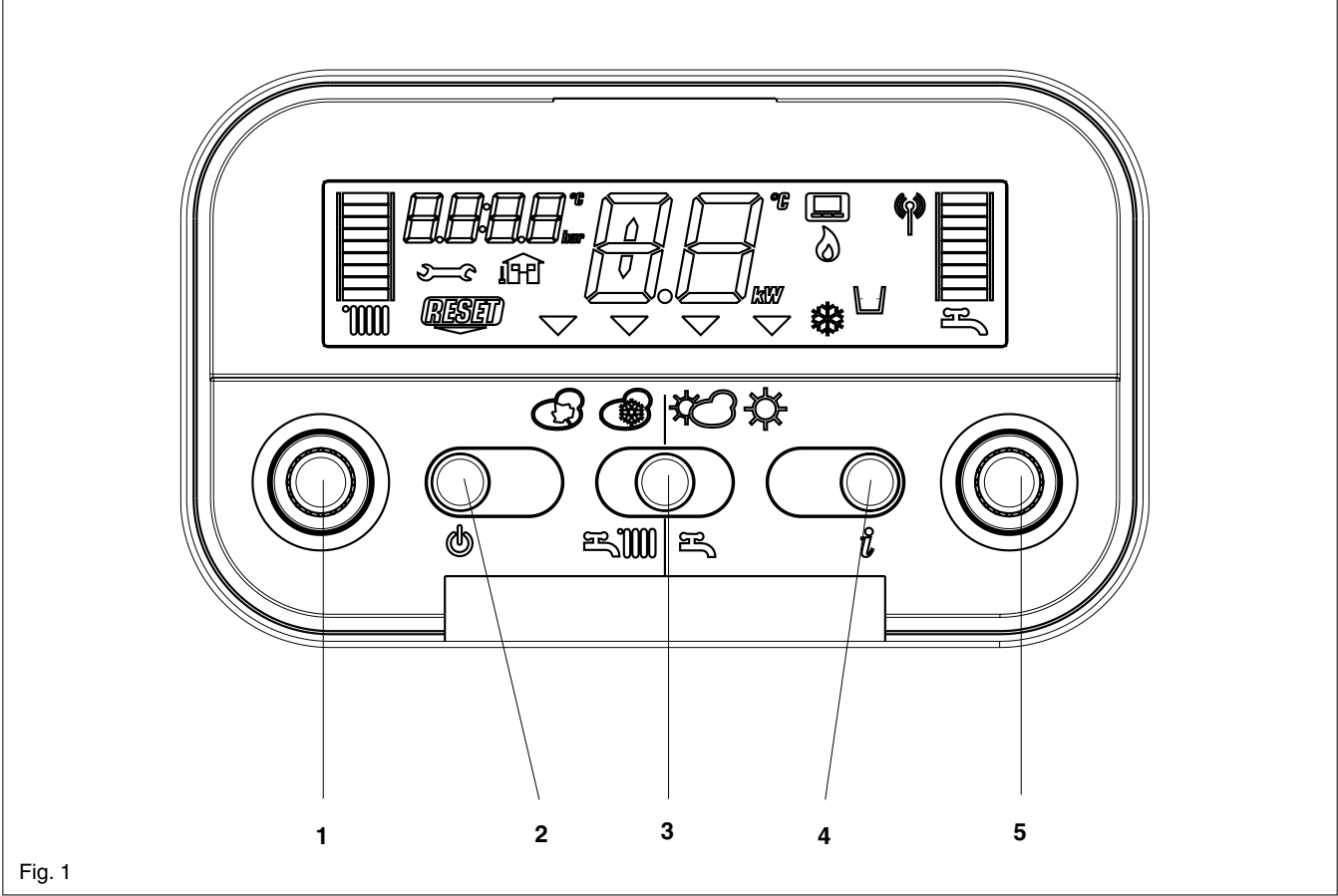

- 1= central heating temperature control
- 2= ON/OFF/RESET button
- 3= MODE button
- 4= INFO button
- 5= hot water temperature control

Symbols description

- Summer
- Spring
- Autumn
- Winter
- central heating temperature bar
- hot water temperature bar
- service request
- reset
- current water pressure
- outside sensor
- current appliance temperature
- error code
- current mode of operation
- burner on
- frost protection on
- insufficient water pressure

THINGS YOU SHOULD KNOW

1.1 GAS APPLIANCE

Gas Safety (Installations and Use) Regulations.

In the interests of your safety and that of others it is a legal requirement that all gas appliances are installed and correctly maintained by a competent person and in accordance with the latest regulations.

1.2 ELECTRICAL SUPPLY

Please ensure that this appliance has been properly connected to the electrical supply by means of a double pole isolator or un-switched socket, and that the correct size of fuse (3 AMP) has been fitted.

Warning: this appliance must be earthed!

1.3 GUARANTEE REGISTRATION CARD

Please take the time to fill out your guarantee registration card. The completed warranty card should be posted within 30 days of installation.

1.4 BENCHMARK LOG BOOK

The **Benchmark** Log Book is supplied with your boiler. This important document must be completed during the installation/commissioning of your boiler. All CORGI Registered Installers carry a CORGI ID card and have a registration number. Both should be recorded in your **Benchmark** Log Book. You can check your installer by calling CORGI direct on 01256 372300. Failure to install and commission the appliance in accordance with the manufacturers instructions may invalidate the warranty. This does not affect your statutory rights.

1.5 HOW DOES IT WORK?

Your Linea HE boiler is a high efficiency combination boiler, which supplies heated water to your radiators and hot water to your taps.

The central heating is controlled via a time clock and/or any thermostats that your installer may have fitted. The boiler will light when a hot water outlet (a tap) is opened. The boiler may also function periodically to pre-heat the hot water heat exchanger. The Linea HE boiler lights electronically and does not have a pilot light. In the unlikely event of a fault developing with your boiler, the supply of gas to the burner will be terminated automatically.

1.6 DIMENSIONS

HEIGHT	845 mm
WIDTH	453 mm
DEPTH	390 mm

1.7 CLEARANCES REQUIRED

ABOVE	150 mm
BELOW	120 mm
SIDES	12 mm
FRONT	600 mm

1.8 FROST PROTECTION SYSTEM

The Linea HE is equipped with a built-in frost protection system, this enables the boiler to override the time controls – if switched off – and operate the burner and/or pump, should the temperature drop below 6 °C.

Please note that the frost protection system is designed to protect the appliance only, should frost protection be required for the central heating system, additional controls may be required.

NOTE

The frost protection system is reliant on the appliance having a permanent electrical supply, and being in a non-fault condition.

1.9 ADDITIONAL CONTROLS

Additional controls such as an external temperature sensor kit or under floor heating safety thermostat are available as optional accessories for this appliance. You should consult your installer and/or the supplementary instructions supplied, on their use (if installed).

GETTING STARTED

2.1 BEFORE SWITCHING ON

Before switching the appliance on please familiarise yourself with:

- how to isolate the appliance from the gas, water and electricity supplies;
- how to check and top-up – if necessary – the system water pressure;
- any external thermostats/time switches and their functions;
- the appliance controls.

2.2 APPLIANCE CONTROLS (see fig. 1)

The appliance controls are concealed behind the front cover. To gain access to the controls simply push-in the release button to open the cover. The appliance is equipped with a simple control panel that can be used to alter or control the following functions:

- ON/OFF selection;
- mode of operation;
- the outlet flow temperature to the central heating system;
- the outlet temperature for domestic hot water.

In addition, the large LCD display shows the status of the appliance:

- current mode of operation;
- current appliance temperature;
- current temperatures selected;
- current system water pressure.

The system water pressure display shows the current pressure of the system, and when the appliance is operating the display may rise or fall, this is quite normal. The minimum permissible level for the safe and efficient operation of the appliance is 0.6 BAR. Should the pressure fall below 0.6 BAR, the boiler may lockout.

Depending on the type of controls specified by your installer you may have an external time clock or programmer fitted, please refer to the instructions supplied with such.

2.3 LIGHTING THE BOILER

Ensure the gas and electrical supply to the boiler are turned on.

Using figure 1 as a guide, locate and press the ON/OFF selection button if the appliance isn't already switched on. The boiler will now go through a self-test sequence. On completion of the self-test sequence, the boiler will be ready to provide heating and/or hot water if required.

2.3.1 MODES OF OPERATION

When the appliance is switched on one of four modes of operation can be selected:

- summer;
- spring;
- autumn;
- winter.

Summer

When the summer mode is selected, the appliance will respond to requests for Domestic Hot Water (DHW). In the summer mode the TSC (Temperature Stability Control) function is active. All heating requests will be ignored.

Spring

When the spring mode is selected, the appliance will respond to requests for Domestic Hot Water (DHW). All heating requests will be ignored.

Autumn

When the autumn mode is selected, the appliance will respond to requests for DHW and/or heating. During the autumn mode, the SARA function (Automatic Temperature Control), and the TSC (Temperature Stability Control) are active.

Winter

When the winter mode is selected, the appliance will respond to requests for DHW and/or heating. During the winter mode, the booster function and pre-heat function are active.

2.3.2 FUNCTIONS

- **TSC:** when the TSC function is active (summer/autumn) the appliance may over-ride the selected DHW temperature in order to maintain temperature stability.
- **SARA:** when the SARA function is active (autumn) and the selected heating temperature is set between 55° – 65°C, the appliance will automatically raise the heating outlet temperature when the selected set temperature cannot be achieved or maintained.
- **BOOSTER:** when the booster function is active (winter), the appliance will automatically raise the heating outlet temperature when the selected set temperature cannot be achieved or maintained.
- **PRE-HEAT:** when the pre-heat function is active (winter), the appliance will periodically heat the DHW heat exchanger to reduce waiting time during DHW requests.
- **FROST PROTECTION:** the frost protection function is active at all times even when the appliance ON/OFF selector is at OFF. Should the temperature fall to 6 °C, the boiler will operate to reduce the risk of frost damage.
- **ANTI-BLOCK:** the anti-block function is active at all times even when the appliance ON/OFF selector is at OFF. Should the appliance be inactive for 19-hours, both the pump and diverter valve actuator will be energised for a short period to reduce the risk of component seizure.

NOTE

The frost protection and anti-block functions are reliant on the appliance having a permanent electrical supply, and being in a non-fault condition.

2.3.3 HEATING REQUEST

When there is a demand for heating via the time clock etc, the boiler will go through an ignition sequence, whereby the burner will light.

When the appliance reaches the set temperature, the burner will go off for minimum period of approximately 5 minutes.

When the programmer/time clock or external thermostats heating request has been satisfied, the appliance will switch off automatically.

2.3.4 HOT WATER REQUEST

When a hot water outlet or tap is opened, the boiler senses water flow and initiates an ignition sequence. The boiler will modulate the output according to the temperature required, when the hot water request has been satisfied, the boiler may continue to operate if the pre-heat function is active.

NOTE

If the appliance fails to ignite during the ignition sequence, it will re-attempt ignition several times before going to a lockout condition. Should this occur, please allow a period of two minutes before re-setting.

2.4 ADJUSTING THE OPERATING TEMPERATURES (see fig.1)

The temperature selector knobs can be rotated to increase or decrease the currently selected temperatures. The display will show any increase or decrease relative to the corresponding selector knob.

2.4.1 ADJUSTING THE CENTRAL HEATING TEMPERATURES (see fig.1)

If an outside temperature sensor is not connected to the boiler the heating selector can be adjusted between 20 °C and 80 °C.

If an outside temperature sensor is connected to the boiler (⏏ on) the central heating temperature is automatically calculated from the boiler in order to have a room temperature of 20 °C. It is possible to adjust this value with the heating selector knob from - 5 °C up to + 5 °C.

2.4.2 ADJUSTING THE HOT WATER TEMPERATURES (see fig.1)

The hot water selector can be adjusted between 35° and 60 °C.

2.5 DIGITAL DISPLAY

The digital display shows the current mode of operation and/or status of the boiler.

Should a fault develop, the display will show a unique fault code that can be used to help rectify the cause of the fault.

Should a fault code be displayed, check the fault code table to identify the cause and course of action to take.

Always wait 2-minutes before pressing the reset button.

2.6 FAULT CODE TABLE

Code	Reason	Action required
10	Ignition anomaly	Reset appliance, if fault continues, call engineer
11	No flame detected	Wait
12	Restarts ignition	Wait
13/14	Wiring fault	Call engineer
20/21/22	Heat exchanger temperature too high	Call engineer
23/31	Wiring fault	Wait
30	Wiring fault	Call engineer
32/34	Fan fault	Call engineer
33/35	Fan fault	Wait
40	Low water pressure	Check/restore system pressure and reset
41	Low water pressure	Check/restore system pressure
42	Pressure gauge fault	Call engineer
50/51/52	Internal fault	Reset appliance, if fault continues, call engineer
53/54/55/56	Internal fault	Reset appliance, if fault continues, call engineer
60/61	Sensor fault	Call engineer
62	Wiring fault	Call engineer
70/72/74	Temperature anomaly	Call engineer
71/73	Temperature anomaly	Wait
75/76	Wiring fault	Call engineer
77	Temperature anomaly	Call engineer
80/90/91	Internal fault	Call engineer
92	Condense pipe blocked	Call engineer
93/95	Condense pipe blocked	Wait
94	Wiring fault	Call engineer

2.7 INFORMATIONMODE

The appliance keypad can be used to display certain information on the working status of the boiler. Push the Info button (i) to enter the info menu (fig. 2). The following information are shown pushing subsequently the i button:

- Info 1** outside temperature (only if outside sensor connected) (fig. 3)
- Info 2** water pressure (fig. 4)
- Info 3** CH temperature set (fig. 5)
- Info 4** DHW temperature set (fig. 4.6).

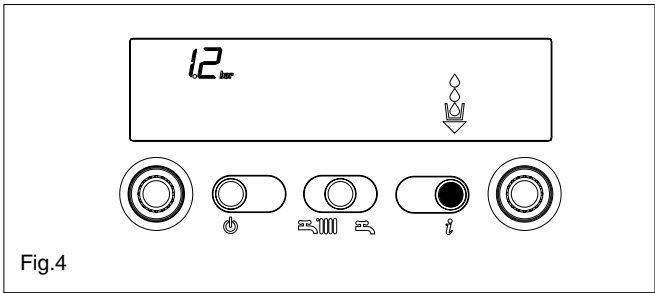

Fig.4

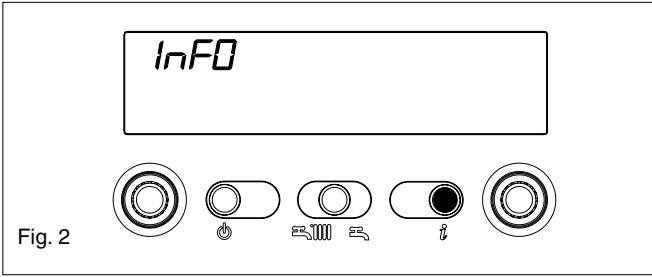

Fig. 2

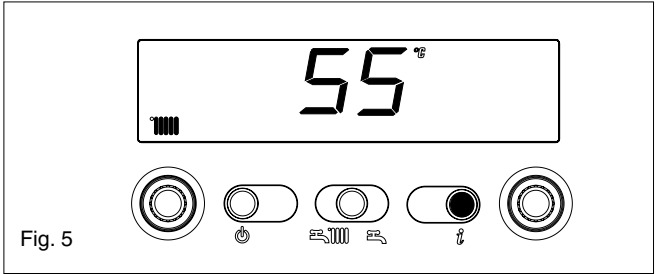

Fig. 5

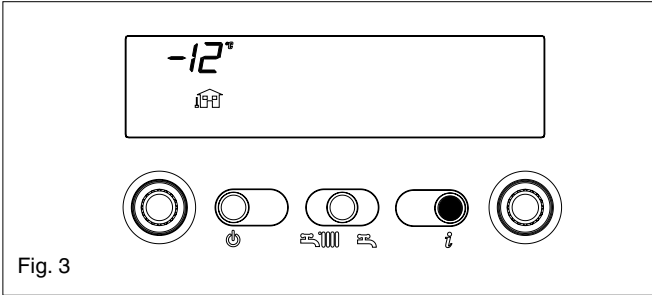

Fig. 3

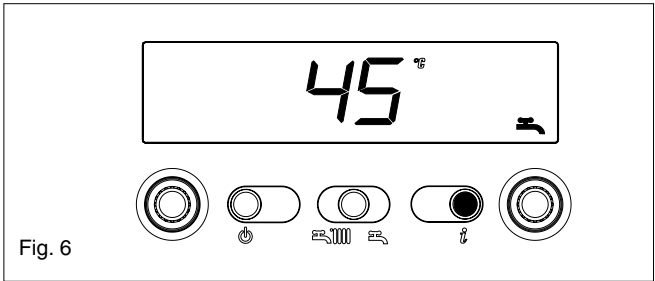

Fig. 6

HOW TO...

3.1 HOW TO TOP-UP THE SYSTEM PRESSURE (fig. 4)

The system pressure must be checked periodically to ensure the correct operation of the boiler. The display should ideally be reading between 0.6 (minimum) and 1.5 (maximum) when the boiler is in an off position and has cooled to room temperature. If the pressure requires 'topping-up' use the following instructions as a guide.

- Locate the filling valve connections (beneath the boiler).
- Attach the filling loop to both connections.
- Open the filling valve slowly until you hear water entering the system.
- Close the filling valve when the displayed pressure (on the boiler) reads between 1 and 1.5.
- Remove the filling loop from the connections **1**

3.2 HOW TO RESET THE APPLIANCE

When the display is flashing, or when the reset icon is shown, the appliance will require to be reset manually. Before resetting the boiler ensure that the displayed pressure is indicating the correct level. Allow a period of two minutes to elapse before pressing the reset button.

IMPORTANT

If the appliance requires to be reset frequently, it may be indicative of a fault, please contact your installer or Vokera Customer Services for further advice.

3.3 HOW TO SHUT DOWN THE SYSTEM FOR SHORT PERIODS

The system and boiler can be shut down for short periods by simply turning the time clock to the off position. It is also advisable to turn off the main water supply to the house.

3.4 HOW TO SHUT DOWN THE SYSTEM FOR LONG PERIODS

If the house is to be left unoccupied for any length of time – especially during the winter – the system should be thoroughly drained of all water.

The gas, water, and electricity supply to the house should also be turned off. For more detailed advice contact your installer.

3.5 HOW TO CARE FOR THE APPLIANCE

To clean the outer casing use only a clean damp cloth. Do not use any scourers or abrasive cleaners.

3.6 HOW TO REGULATE THE HOT WATER TEMPERATURE

Usually your installer will have adjusted the hot water output to suit your requirements, however if you would like to adjust the outlet temperature, please follow the instructions in section 2.4.

NOTE

If you find that the hot water temperature is still insufficient, try reducing the flow of water through the tap.

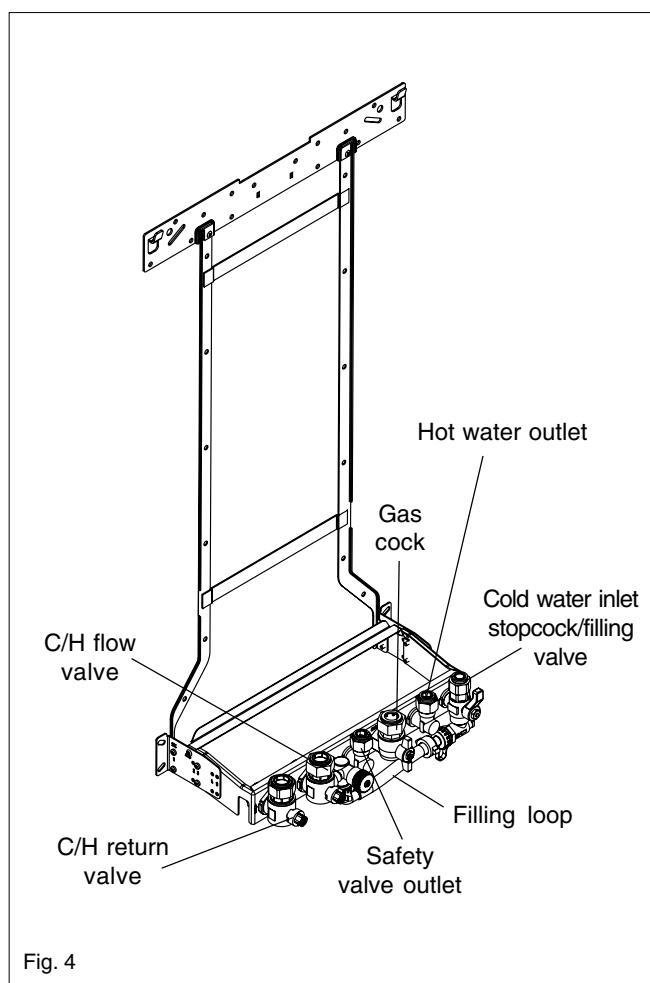

Fig. 4

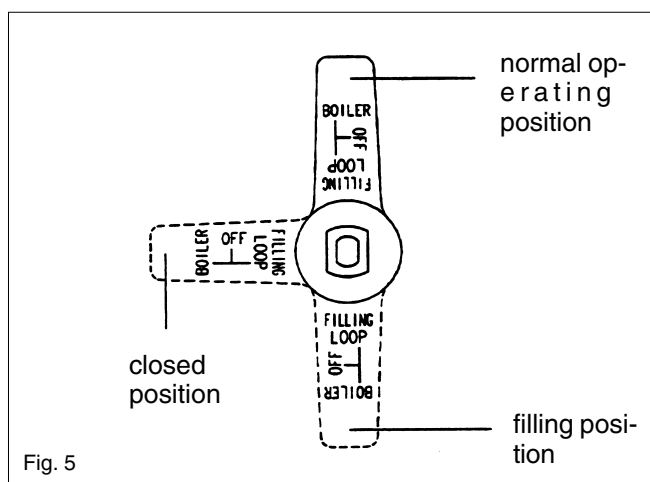

Fig. 5

WHAT IF...

4.1 WHAT IF I SUSPECT A GAS LEAK

If you suspect a gas leak, turn off the gas supply at the gas meter, and contact your installer or local gas supplier. If you require further advice please contact your nearest Vokera office.

4.2 WHAT IF I HAVE FREQUENTLY TO TOP-UP THE SYSTEM

If the system regularly requires topping-up, it may be indicative of a leak. Please contact your installer and ask him to inspect the system.

4.3 WHAT IF THE RESET LIGHT IS ON

If the reset icon is shown, it indicates that the boiler has failed to ignite or has overheated, when this happens the boiler automatically shuts down and requires to be reset manually (see 3.2).

4.4 WHAT IF THE APPLIANCE IS DUE ITS ANNUAL SERVICE

Advice for tenants only

Your landlord should arrange for servicing.

Advice for homeowners

Please contact Vokera Customer Service (**0870 333 0220 (UK) or 05655057 (ROI)**) if you would prefer a Vokera service engineer or agent to service your appliance. Alternatively your local CORGI registered engineer may be able to service the appliance for you.

4.5 WHAT IF I NEED TO CALL AN ENGINEER

If you think your boiler may have developed a fault please contact your installer or Vokera Customer Services (**0870 333 0220 (UK) or 05655057 (ROI)**) have all your details to hand including full address and postcode, relevant contact numbers, and your completed appliance log book.



Cod. 10026492 - 10/05 - Ed. 2

Registered address:

Vokèra Ltd
Borderlake House
Unit 7 Riverside Industrial Estate
London Colney
Herts AL2 1HG

enquiries@vokera.co.uk

www.vokera.co.uk
www.vokera.ie

Sales, General Enquires

T 0844 391 099
F 0844 391 0998

Vokèra Ireland
West Court, Callan
Co Kilkenny
T 056 7755057
F 056 7755060

Vokèra Limited reserve the right to change
specification without prior notice
Consumers statutory rights are not affected.

A Riello Group Company.
Company Reg No: 1047779