

To be left with the user



Instructions for Use, Installation and Servicing ecoMAX pro

GB

Wall hung condensing	18 E
boilers for traditional open vented systems	28 E

THIS DOCUMENT HAS BEEN PROVIDED BY



PLEASE VISIT WWW.HEATINGSARES247.COM FOR FURTHER
INFORMATION AND GENUINE PARTS & SPARES AT LOW PRICES



Table of Contents

	Page		Page
1 List of Contents	4	6 Boiler Location and Ventilation	12
Contents included with ecoMAX pro boiler ...	4	6.1 Boiler Location	12
2 Introduction	5	6.2 Clearances	12
2.1 General Information	5	6.3 Timber Frame Buildings	12
2.2 Gas Category	5	6.4 Room Ventilation	12
2.3 Gas Safety (Installation and Use) Regulations	5	6.5 Compartment Ventilation	12
2.4 Gas Testing and Certification	5	7 Flue	13
2.5 CE Mark	5	7.1 Flue Position and Length	13
2.6 Control of Substances Hazardous to Health ..	5	7.2 Flue termination	13
2.7 Spare Parts	5	7.3 Internal Flue Installation	14
2.8 Manual Handling Guidance	5	7.4 Flue Options	14
2.9 Warnings	5	8 Installation Preparation	14
2.10 Protection Against Freezing	6	8.1 Unpacking of Boiler	14
2.11 Boilers Installed in a Compartment or Cupboard	6	8.2 Using boiler template	14
2.12 Boiler Casing	6	8.3 Rear flue exit	15
2.13 Condensate Drain	6	8.4 Other flue options	15
2.14 Plumbing from flue terminal	6	8.5 Flue Hole Cutting	15
2.15 Cleaning	6	9 Boiler fixing	15
2.16 Maintenance and Servicing	6	9.1 Fitting the boiler hanging bracket	15
2.17 Guarantee	7	9.2 Boiler Fixing	15
3 Operating the Boiler	7	10 Gas, Water and Condensate Connections	16
3.1 Sealed Central Heating Systems only.	7	10.1 Gas Connection	16
3.2 All Systems	7	10.2 Water Connections	16
3.3 User Controls	7	10.3 Condensate Drain Connection	16
3.4 To Turn the Boiler Off	8	11 Flue Preparation and Installation	17
4 General Information	8	11.1 Flue Length	17
4.1 Sheet Metal Parts	8	11.2 Extension pipes	17
4.2 Statutory Requirements	8	11.3 Flue Assembly	18
4.3 Gas supply	8	11.4 Flue Attachment To Boiler	18
4.4 Technical Data	8	12 Electrical Connections	19
4.5 Electrical Supply	9	12.1 Mains, external controls and pump connections	
4.6 Condensate Drain	9	(mains voltage)	19
4.7 Heating System Controls	9	12.2 Electrical connections - testing	19
5 Water system	9	13 Commissioning	20
5.1 Draining Tap	9	13.1 Preliminaries - All Systems	20
5.2 Safety Valve	9	13.2 Sealed Systems	20
5.3 Pump	10	13.3 Gas supply	20
5.4 Bypass	10	13.4 Initial Lighting	20
5.5 Inhibitor	10	13.5 Testing - Gas	21
5.6 Open (Vented) Water System	10	13.6 Testing - Heating System	21
5.7 Domestic Hot Water Cylinder	10	13.7 User Controls and Options	21
5.8 Domestic Hot Water System - unvented	10	13.8 Temperature Display	21
5.9 Sealed water Systems	11	13.9 Pump Exercise Programme	21
5.9.1 Safety Valve	11	13.10 Handover to user	21
5.9.2 Expansion Vessel	11		
5.9.3 Pressure Gauge	11		
5.9.4 Domestic Hot Water Cylinder	11		
5.9.5 Water Makeup	11		
5.9.6 Filling a Sealed Water System	11		
5.10 Water Treatment	11		

	Page
14 Servicing	22
14.1 General	22
14.2 Spark Electrode	22
14.3 Burner	22
14.4 Combustion Chamber and Heat Exchanger. . .	23
14.5 Condensate Drain	23
14.6 Inner Casing Panel Seal Check.	23
15 Fault Finding	25
16 Short Spare Parts	27
17 Boiler Specification	28

1 List of contents

1 List of contents

1.1 Contents included with ecoMAX pro boiler

Ensure that all contents are included before commencing installation.

Vaillant Ltd. support the Benchmark initiative. Within the information pack you will find a Benchmark Log Book. It is very important that this is completed correctly at the time of installation, commissioning and handover to the user.

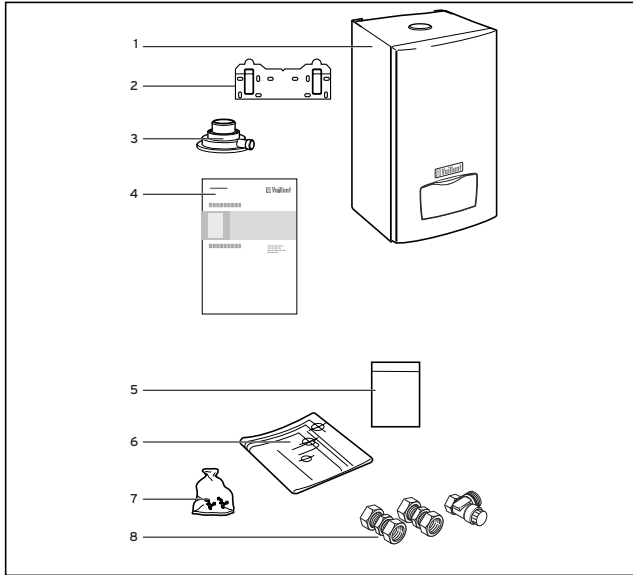

The mark of quality for domestic heating

Fig. 1.1: Items supplied with unit (ecoMAX pro)

Item	Quantity	Description
1	1	Boiler
2	1	Hanging bracket
3	1	Flue connection adaptor
4	1	Instruction booklet
5	2	Guarantee card and envelope and log book
6	1	Template
7	1	Screws/wallplugs
8	1	Gas service valve and compression couplers

2 Introduction

2.1 General Information

Thank you for choosing a Vaillant boiler. The information given in this booklet will enable you to obtain the best performance from your boiler.

The Benchmark logbook should be completed by the installer and/or commissioning engineer and handed to the user.



Note!

This boiler must be installed and serviced by a competent person in accordance with the Gas Safety (Installation and Use) Regulations 1998. In the UK 'CORGI' registered installers undertake the work to a safe and satisfactory standard.

This boiler is designed to provide central heating from a fully pumped open-vented or sealed water system with a fully indirect cylinder.

The central heating water temperature can be adjusted on the boiler.

Once the controls are set the boiler operates automatically.

A frost protection programme is also included.

Please read these instructions and follow them carefully for the correct and economical use of your boiler.

2.2 Gas Category

This boiler is for use only on Natural gas (G20).

2.3 Gas Safety (Installation and Use) Regulations

In your own interests and that of safety, it is the Law that ALL gas appliances are installed by a competent person in accordance with the current issue of the above regulations.

2.4 Gas Testing and Certification

The boiler is tested and certificated for safety and performance. It is, therefore, important that no alteration is made to the boiler.

2.5 CE Mark

This boiler meets the requirements of Statutory Instrument, No. 3083 The Boiler (Efficiency) Regulations, and therefore is deemed to meet the requirements of Directive 92/42/EEC on the efficiency requirements for new hot water boilers fired with liquid or gaseous fuels.

Type test for purposes of Regulation 5 certified by: Notified body 0086.

Product/production certified by: Notified body 0086.

The CE mark on this appliance shows compliance with:

1. Directive 90/396/EEC on the approximation of the

laws of the Member States relating to appliances burning gaseous fuels.

2. Directive 73/23/EEC on the harmonisation of the Laws of the Member States relating to electrical equipment designed for use within certain voltage limits.

3. Directive 89/336/EEC on the approximation of the Laws of the Member States relating to electromagnetic compatibility.

2.6 Control of Substances Hazardous to Health

Under Section 6 of The Health and Safety at Work Act 1974, we are required to provide information on substances hazardous to health.

The adhesives and sealants used in this appliance are cured and give no known hazard in this state.

2.6.1 Insulation Pads

These can cause irritation to skin, eyes and the respiratory tract.

If you have a history of skin complaint you may be susceptible to irritation. High dust levels are usual only if the material is broken.

Normal handling should not cause discomfort, but follow normal good hygiene and wash your hands before eating, drinking or going to the lavatory.

If you do suffer irritation to the eyes or severe irritation to the skin seek medical attention.

2.7 Spare Parts

Only original Vaillant spare parts may be used.

2.8 Manual Handling Guidance

During the appliance installation and the replacement of the heat exchanger it will be necessary to employ caution and assistance whilst lifting as the appliance or component exceeds the recommended weight for a one man lift.

In certain situations it may be required to use a mechanical handling aid.

Take care to avoid trip hazards, slippery or wet surfaces.

2.9 Warnings

Gas Leak or Fault

If a gas leak or fault exists or is suspected, turn the boiler mains electrical supply off and turn off the gas supply at the meter. Consult your local gas company or your local installation/servicing company.

Clearances

If fixtures are positioned close to the boiler, space must be left as shown in Fig. 6.1. Enough space must also be left in front of the boiler to allow for servicing.

2 Important information

Sheet Metal Parts

This boiler contains metal parts (components) and care should be taken when handling and cleaning, with particular regard to edges.

Sealed Components

Under no circumstances must the User interfere with any sealed component as this could result in a potentially dangerous situation arising.

Electrical Supply Failure

This boiler must be earthed.

The boiler will not work without an electrical supply. Normal operation of the boiler should resume when the electrical supply is restored.

Reset any external controls to resume normal operation of the central heating.

If the boiler does not resume normal operation turn the mains reset switch off and on. If the boiler does not resume normal operation after this the overheat thermostat may have operated. The overheat thermostat would only operate under abnormal conditions and, under these circumstances; it would be advisable to consult your installation / servicing company.

2.10 Protection Against Freezing

The boiler has a built in frost protection programme as long as the electricity and gas are left switched on. This device operates the burner and system pump when the temperature inside the boiler falls to 3 °C.

Any other exposed areas of the system should be protected by a separate frost thermostat.

If the mains electricity and gas are to be turned off for any long periods during severe weather, it is recommended that the whole system, including the boiler, should be drained to avoid the risk of freezing. Make sure that, if fitted, the immersion heater in the cylinder is switched off.

If you have a sealed water system contact your installation/ servicing company as draining, refilling and pressurising MUST be carried out by a competent person.

As a safety feature the boiler will stop working if the condensate drain becomes blocked. During freezing conditions this may be due to the forming of ice in the condensate drain external to the house. Release an ice blockage by the use of warm cloths on the pipe. The boiler should then restart. Contact your installation/ servicing company if the fault persists.

2.11 Boilers Installed in a Compartment or Cupboard

If the boiler is fitted into a compartment or cupboard it does not require ventilation openings.

Do not use the compartment or cupboard for storage.

2.12 Boiler Casing

Do not remove or adjust the casing in any way, as incorrect fitting may result in incorrect operation or failure to operate at all.

2.13 Condensate Drain

The condensate drain, see section 10.3, must not be modified or blocked.

2.14 Plumbing from flue terminal

All condensing boilers produce a plume of water vapour from the flue terminal. This is due to the high efficiency and hence low flue gas temperature. This may increase in wet, damp weather but this is completely normal and indicates that the boiler is operating correctly.

2.15 Cleaning

This appliance contains metal parts and care should be taken when handling and cleaning with particular regard to edges.

The boiler casing can be cleaned using a mild liquid detergent with a damp cloth, then a dry cloth to polish. Do not use any form of abrasive or solvent cleaner as you may damage the paintwork.

2.16 Maintenance and Servicing

For the continued efficient and safe operation of the boiler it is recommended that it is checked and serviced at regular intervals. The frequency of servicing will depend upon the installation conditions and usage, but in general, once a year should be enough.

If this appliance is installed in a rented property there is a duty of care imposed on the owner of the property by the current issue of the Gas Safety (Installation and Use) Regulations, Section 35.

Servicing/maintenance should be carried out by a competent person in accordance with the rules in force in the countries of destination.

To obtain service, please call your installer or Vaillant Service Solutions (0870 6060 777).

Please be advised that the installation engineer on completion of commissioning and servicing should complete the 'Benchmark' logbook.

All CORGI Registered Installers carry a CORGI ID card, and have a registration number. Both should be recorded in your boiler Logbook. You can check your installer is CORGI registered by calling CORGI direct on: - 01256 372300.

2.17 Guarantee

Our confidence in the quality of craftsmanship and performance of our products is demonstrated by the Vaillant two year guarantee.

During the first year from installation the guarantee covers your boiler against manufacturing defects for both parts and labour. In order to extend this guarantee to the second year from installation all you have to do is ensure that your boiler receives a service when it is a year old. (Please note that the cost of the service is not included in the guarantee).

Should your boiler develop a fault please contact your original installer or alternatively contact Vaillant Service Solutions on 0870 6060 777.

IMPORTANT...

to qualify for your two year guarantee:

Please complete the registration details on the guarantee card and return in the pre-paid envelope to:

Vaillant Registration Department

Freepost CV 2560

BEDWORTH

Warwickshire

CV12 8BR

The registration card must be returned within 30 days of the boiler being installed.

The boiler must be serviced either by Vaillant Ltd. or another competent servicing company (CORGI registered) within one year of the installation date and the details recorded in the "Installation, Commissioning and Service Record Log Book" (this log book should have been completed and left with you by your installer). Please note that the cost of the service is not included in the guarantee.

Vaillant is a member of the Benchmark initiative and fully supports the aims of the programme. Benchmark has been introduced to improve the standards of installation and commissioning of central heating systems in the UK and to encourage the regular servicing of all central heating systems to ensure safety and efficiency.

3 Operating the Boiler

3.1 Sealed Central Heating Systems only.

CAUTION. A sealed water system must be filled and pressurised by a competent person.

Only light the boiler when you are sure that the system and boiler have been filled and pressurised.

The pressure should read at least 0.7 bar, when the system is cold. If the needle displays a value below this, follow the instructions left by your installer to refill the system.

Alternatively your installer should be called to refill the system.



3.2 All Systems

Check that the electrical supply to the boiler is ON at the external isolator.

Set any remote heating system controls as required.

3.3 User Controls

Slide the On / Off control down to the I position to turn on the boiler. The operating indicator will illuminate (green) to show that the boiler is on.

The temperature of the central heating water can be adjusted by pushing the mode button () until the radiator symbol is displayed. Pushing the + or - buttons will then set the water temperature as desired. (Typical setting temperatures for a normal radiator heating system will be in the range of 60 °C to 80 °C. Note that set temperatures below 60 °C will not sufficiently heat any hot water cylinder). To return to the normal mode push the mode button () until the display shows the current temperature of water in the boiler.

When the boiler is operating the flame symbol will be shown in the display. The bar symbol is also shown and this indicates the modulating output of the boiler. The boiler will automatically modulate to the output needed by the heating system - the more bars that are displayed, the higher the output.

The ecoMAX pro is a fan flue appliance and the operation of the fan may be heard when the boiler is running and for a short period after the boiler has stopped.

Should a fault condition occur the operating indicator will flash red and will be accompanied by an "F" symbol in the display. To reset the boiler slide the On / Off control to the Off (O) position and after 5 seconds back to the On (I) position. The boiler should now operate.

If the fault persists contact your installer / service provider.

The ecoMAX pro has a Holiday / frost mode. If you are going on holiday and do not want the boiler to be operated by the external heating controls press the mode button () until the MODE indicator flashes in the left hand edge of the display. Then press the + or - button until the arrow indicator points to the holiday symbol. The boiler will now only operate if necessary for frost protection of the boiler itself as well as running a daily pump exercise programme to prevent sticking. It will not be turned on and off by the external heating controls. If a system frost protection thermostat has been fitted this will remain active.

4 General Information

3.4 To Turn the Boiler Off

Normally the boiler will be turned off by the heating system controls. The mains On / Off control may be used to switch off the boiler, however it is preferable to leave the electrical supply on whenever possible to permit operation of the built-in frost protection and daily pump exercise programme.

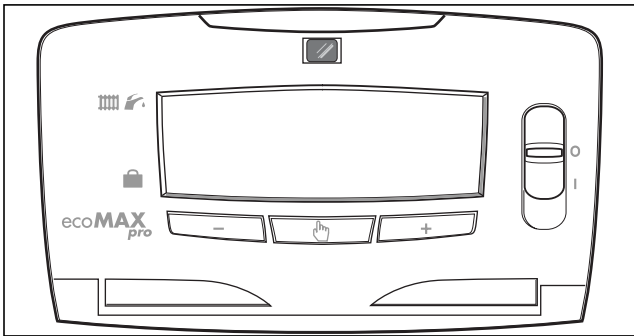

Fig. 3.1

4 General Information

Important notice

The boiler is supplied in one pack and the flue is supplied separately. This boiler is for use only on G20 natural gas. Where no British Standards exists, materials and equipment should be fit for their purpose and of suitable quality and workmanship. Refer to Manual Handling Operations, 1992 regulations. The installation of this boiler must be carried out by a competent person in accordance the rules in force in the countries of destination. Manufacturer's instructions must not be taken as overriding statutory requirements.

4.1 Sheet Metal Parts



Warning!

When installing the appliance, care should be taken to avoid any possibility of personal injury when handling sheet metal parts.

4.2 Statutory Requirements

The installation of the boiler MUST be carried out by a competent person in accordance with the relevant requirements of the current issue of: Manufacturer's instructions supplied. The Gas Safety (Installation and Use) Regulations, The Building Regulations, The Building Standard (Scotland) Regulations, Water Supply (Water Fittings) Regulations, Water Bylaws, The Health and Safety at Work, Act, Control of Substances Hazardous to Health, The

Electricity at Work Regulations and any applicable local regulations.

Detailed recommendations are contained in the current issue of the following British Standards and Codes of Practice, BS4814, BS5440 Part 1 and 2, BS5449, BS5546, BS6700, BS6798, BS6891 and BS7074 Part 1 and 2, BS7478, BS7593, BS7671.

4.3 Gas Supply

The gas installation must be in accordance with the current issue of BS6891.

The supply from the governed meter must be of adequate size to provide a steady inlet working pressure of 20mbar (8in wg) at the boiler.

On completion, test the gas installation for soundness using the pressure drop method and suitable leak detection fluid, purge in accordance with the above standard.

4.4 Technical Data

All dimensions are given in millimetres (except as noted). See Fig. 4.1.

The data label is positioned on the combustion chamber cover see fig. 4.2.

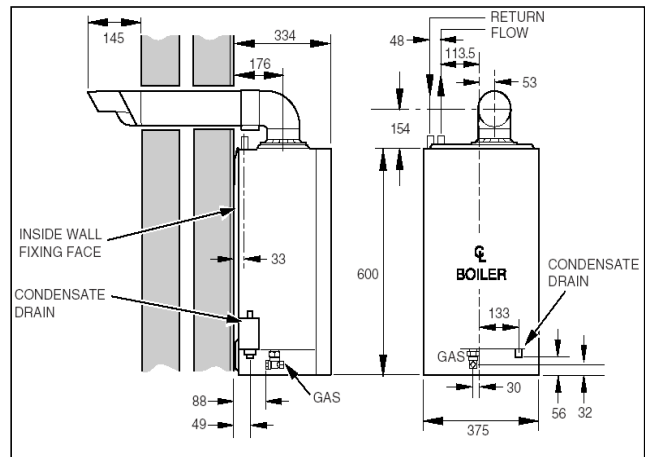

Fig. 4.1



Fig. 4.2

4.5 Electrical Supply

The boiler must be earthed. All system components shall be of an approved type and all wiring to current I.E.E. wiring regulations. The boiler must be connected to a permanent 230 V ac, 50 Hz supply. Connection of the whole electrical system of the boiler, including any heating controls, to the electrical supply must be through one common isolator and must be fused 3 Amp maximum. Isolation should be by a double pole switched fused spur box, with a minimum gap of 3mm for both poles. The fused spur box should be readily accessible and preferably adjacent to the appliance. It should be identified as to its use. Alternatively connection can be made through an unswitched shuttered socket and 3A fused 3-pin plug both to the current issue of BS 1363 may be used, provided they are not used in a room containing a bath or shower. The colours of three core flexible cable are, blue - neutral, brown - live, green and yellow - earth.

4.6 Condensate Drain

A plastic drain pipe must be fitted to allow discharge of condensate to a drain. Condensate should, if possible, be discharged into the internal household draining system. If this is not practical, discharge can be made externally into the household drainage system or a purpose designed soak away, see Section 10.3 for more details.

4.7 Heating System Controls

It is recommended that a programmer and room thermostat control the boiler. Thermostatic radiator valves may be installed, however they must not be fitted in a room where the room thermostat is located.

Note!
All systems must have at least one radiator not fitted with a thermostatic valve.

Note!
For further information, see the current issue of the Building Regulations, approved document L1, and the references:

- 1) GIL 59, 2000: Central heating system specification (CheSS) and
- 2) GPG 302, 2001: Controls for domestic central heating system and hot water. BRECSU.

5 Water system

5.1 Draining Tap

A draining tap must be provided at the lowest point of the system, which will allow the entire system and hot water system to be drained. Draining taps shall be to the current issue of BS 2879.

5.2 Safety Valve

A safety valve need not be fitted to an open-vented system.

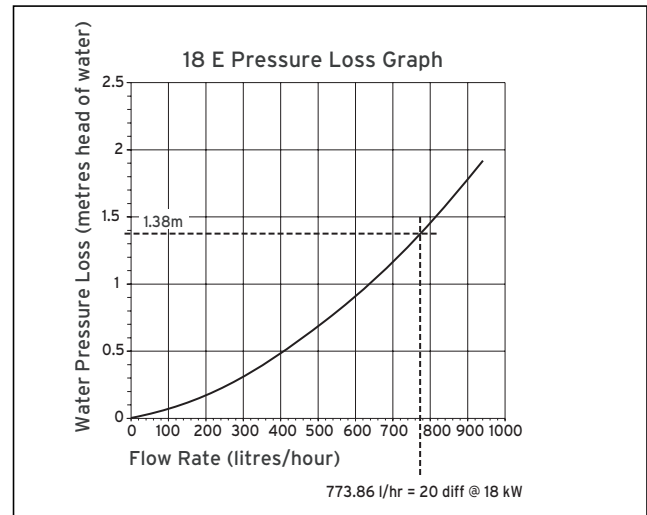

Fig. 5.1

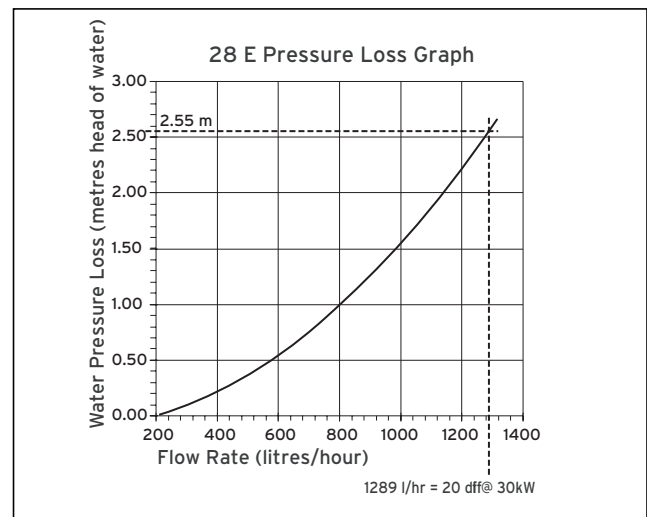

Fig. 5.2

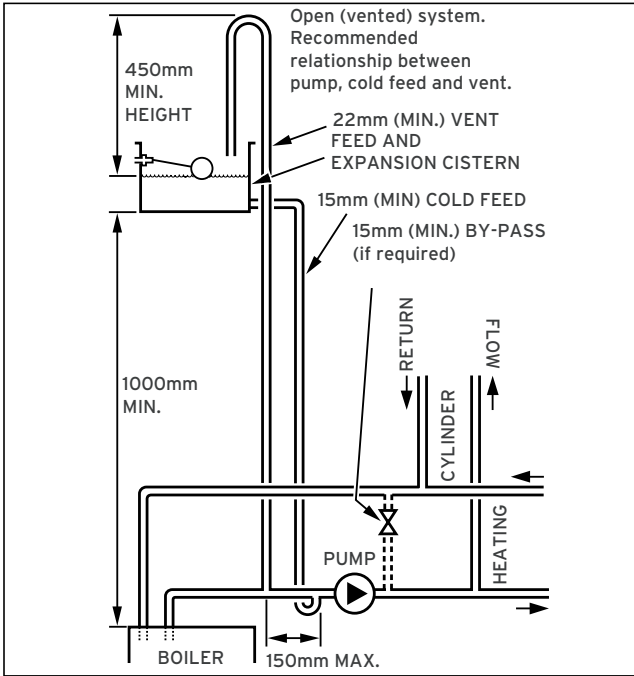

Fig. 5.3

Model	Minimum flow rate
ecoMAX pro 18 E	773.8 litres/hr
ecoMAX pro 28 E	1289 litres/hr
This is equal to 20 °C differential at maximum heat input.	

Table 5.1 Flow rate

5.3 Pump

The pump should be fitted on the flow pipe from the boiler and have isolating valves each side. A variable duty pump should be set to give a temperature difference of no greater than 20 °C between the flow and return, with the thermostat set at "MAX", which is about 80 °C, to give a flow rate as shown in table 5.1. See chart for pressure loss of the boiler, Fig. 5.1 or 5.2. High resistance microbore systems may require a higher duty pump.

5.4 Bypass

A bypass is not required on the central heating system unless all radiators are fitted with thermostatic radiator valves or the system controls could allow the boiler and pump to operate when there is no flow. Where a bypass has to be fitted, the bypass must be placed at least 1.5 metres away from the boiler.

5.5 Inhibitor

Attention is drawn to the current issue of BS 5449 and BS 7593 on the use of inhibitors in central heating systems.

If an existing system is to be reused take special care to drain the entire system, including the radiators, then thoroughly cleaning out before fitting the boiler whether or not adding an inhibitor.

For advice please refer to 5.10, Water Treatment.

5.6 Open (Vented) Water System

The boiler must be supplied from an unrestricted water supply taken from a feed and expansion cistern situated at a maximum height of 27 metres (90ft) above the boiler.

The cold feed must be 15mm minimum size.

The vent must rise continuously and be unrestricted. It is important that the relative positions of the pump, cold feed and open vent are as shown in Fig. 5.3.

5.7 Domestic Hot Water Cylinder

Warning!
 **Single feed indirect cylinders are not suitable.**

The domestic hot water cylinder must be of the double feed fully indirect coil type.

5.8 Domestic Hot Water System - unvented

Where a storage system will not have a vent to atmosphere the installation must comply with the building regulations and local Water Company bylaws, see also the current issue of BS5546 and BS6700. If fitting to an existing system the local authority should be informed.

Note!
 **ecoMAX pro boilers are not suitable for use with Vaillant VANTAGE unvented cylinders and MUST not be used in connection with these cylinders.**

5.9 Sealed water Systems

The installation must comply with the appropriate requirements of the current issue of BS4814, BS5449, BS6759, BS6798 and BS7074 Part 1 and 2. See Fig. 5.4 for a suggested layout.

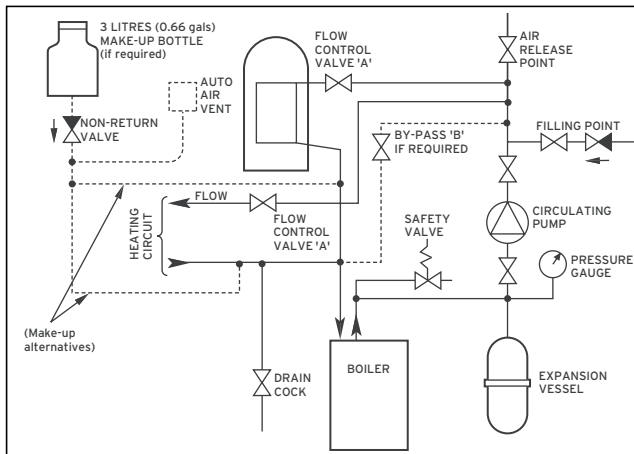

Fig. 5.4

5.9.1 Safety Valve

A safety valve must be fitted to a sealed system. It shall be preset, non-adjustable with a lift pressure of 3 bar, incorporating seating of a resilient material, a test device and a connection for drain. The safety valve discharge pipe must be routed to outside the building, must not discharge above an entrance or window or any type of public access area, be clear of any electrical fittings and positioned so that any discharge can be seen.

5.9.2 Expansion Vessel

A diaphragm type expansion vessel, conforming to the current issue of BS4814 (see also BS7074 Part 1 and 2) must be connected at a point close to the inlet side of the circulating pump, see the diagrammatic layout, Fig. 5.4. unless laid down differently by the manufacturer. The expansion vessel volume depends on the total water system volume and the initial system design pressure. For any system an accurate calculation of vessel size is given in the current issue of BS5449 and BS7074 Part 1. **Example:** For an initial design pressure of 0.7 bar, the minimum total vessel volume required is $0.063 \times \text{Total System Volume}$.



Note!

A higher initial design pressure requires a larger volume expansion vessel.

The charge pressure must not be less than the static head of the system, that is, the height of the highest point of the system above the expansion vessel.

5.9.3 Pressure Gauge

A pressure gauge with a set pointer and covering at least 0 to 4 bar (0 to 60 lb/in²) shall be fitted permanently to the system in a position where it can be seen when filling the system.

5.9.4 Domestic Hot Water Cylinder

The domestic hot water cylinder must be of the double feed fully indirect coil type. It must be suitable for working at a gauge pressure of 0.35 bar above the safety valve setting.

5.9.5 Water Makeup

Provision should be made for replacing water loss from the system using a make up bottle mounted in a position higher than the top point of the system, connected through a non-return valve to the return side of either the heating circuit or the hot water cylinder. Alternatively, provision for make up water should be made using a proprietary filling loop.

5.9.6 Filling a Sealed Water System

Provision for filling the system at low level must be made. This can be achieved by the use of a proprietary filling loop.

5.10 Water Treatment

For optimum performance after installation, the boiler and its associated central heating system should be flushed in accordance with BS7593: 1992 using a cleanser.

For advice on the application of system cleansers and inhibitors contact either;

Fernox, Alpha-Fry Technologies

Tandem House

Marlow Way

Beddington Farm Road

Croydon CR0 4XS

Tel: 0870 601 5000

Fernox technical help line

01799 550811

or:

Sentinel, GE Betz

Widnes

Cheshire, WA8 8UD

Tel: 0151 420 9595

6 Boiler Location and Ventilation

6 Boiler Location and Ventilation

6.1 Boiler Location

The boiler may be installed in any room although particular attention is drawn to the requirements of the current issue of BS7671 with respect to the installation of a boiler in a room containing a bath or a shower. Any electrical switch or boiler control using mains electricity should be so situated that a person using the bath or shower cannot touch it. The electrical provisions of the Building Standards (Scotland) Regulations are applicable to such installations in Scotland.

The boiler must be mounted on a flat wall, which is sufficiently robust to take its total weight.

The boiler is not suitable for fitting outdoors.

Any electrical switch or boiler control using mains electricity must be positioned so that a person using a bath or shower cannot touch it.

6.2 Clearances

The boiler should be positioned so that at least the minimum operational and servicing clearances are provided, see Fig. 6.1.

Additional clearances may be beneficial around the boiler for installation and servicing.

For flue installations where external access is not practicable, consideration should be given for the space required to insert the flue internally, which may necessitate clearance larger than those specified in Fig. 6.1.

6.3 Timber Frame Buildings

If the boiler is to be installed in a timber frame building it should be fitted in accordance with the Institute of Gas Engineers document IGE/UP/7/1998.

6.4 Room Ventilation

The boiler is room sealed, so when it is installed in a room or space, a permanent air vent is not required.

6.5 Compartment Ventilation

If the boiler is installed in a compartment, a permanent air vent is not required.

Leave existing air vents.

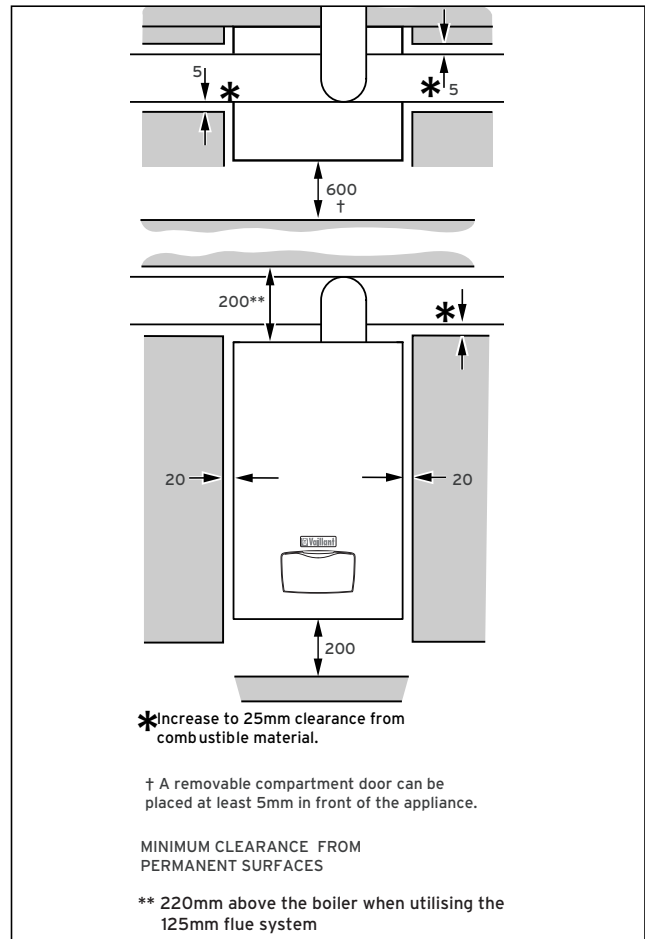

Fig. 6.1

7 Flue

7.1 Flue Position and Length

The standard horizontal flue is fitted onto the top of the boiler.

See Fig. 7.1 and 7.2 to determine whether a standard flue can be used.

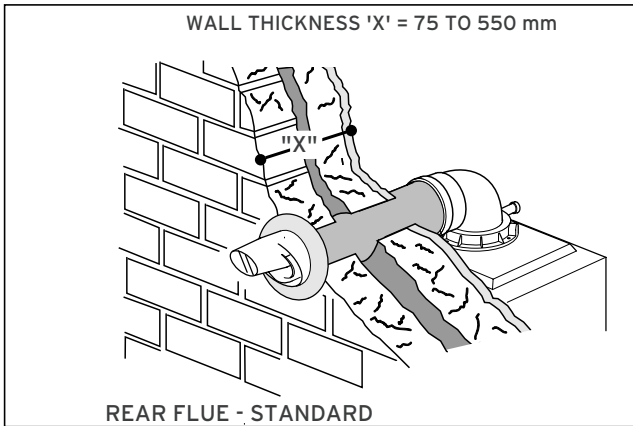

Fig. 7.1

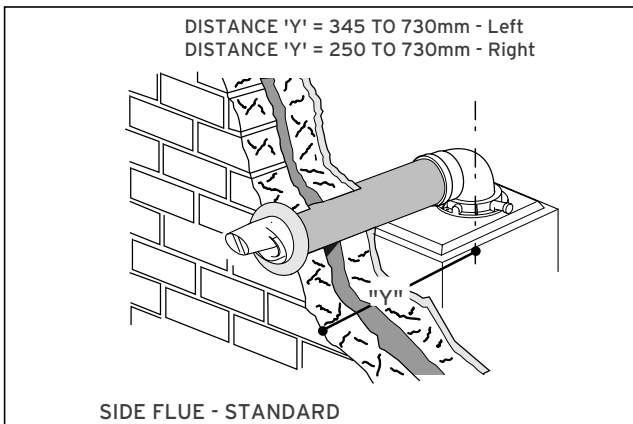

Fig. 7.2

Flue system

The standard 100mm flue system (Art. No. 303 930) is suitable for installations up to 730 mm measured from the centre of the boiler flue outlet to the outside face of the wall.

Flue extensions are available to extend this length up to 10.8m (see section 11.2). Both 90° bends and 45° elbows are also available to increase siting flexibility.

A concentric flue system of 125 mm outside diameter is available and can be used to achieve flue lengths up to 20 m.

A vertical flue system is also available.

Refer to flue system installation instructions for full details.

When extension pipes are used the flue system must be designed to have a continuous fall to the boiler of at least 3° to allow condensate to run out via the drain.

7.2 Flue termination

The following details refer to both flue systems.

- The terminal must be positioned such that the products of combustion can disperse freely at all times.
- In certain weather conditions a plume of water vapour may be visible from the flue terminal. Positions where this could be a nuisance should be avoided.
- If the terminal is fitted less than 2 m above a balcony, above ground or above a flat roof to which people have access then a suitable terminal guard must be provided and fitted (A suitable guard is manufactured by: Tower Flue Components, Morley Road, Tonbridge, Kent, TN9 1RA. Size: 280mm x 280mm x 270mm).

Note!
 Vertical flues must not terminate within 600 mm of an openable window, air vent or any other ventilation opening.

The flue assembly shall be so placed or shielded as to prevent ignition or damage to any part of the building.

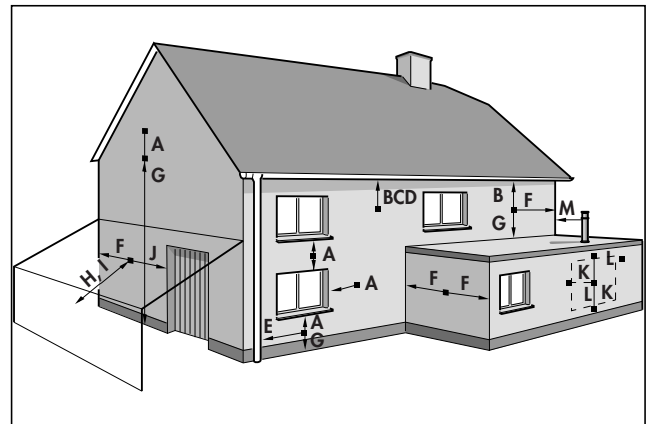

Fig. 7.3

Terminal position		mm
A ¹⁾	Directly below an opening, above an opening or horizontal to an opening i.e. air brick, opening window or other, etc	300
B	Below gutters, soil pipes or drain pipes	75 ²⁾
C	Below eaves	200 ²⁾
D	Below balconies	200 ²⁾
E	From vertical drain pipes and soil pipes	25
F	From internal or external corners	300 ³⁾
G	Above ground, roof or balcony	300
H	From a surface facing a terminal	600 ⁴⁾
I	From a terminal facing a terminal	1200
K	Vertically from a terminal on the same wall	1500
L	Horizontally from a terminal on the same wall	300
M	Distance from adjacent wall for vertical Flue	500

- 1) In addition, the terminal should not be nearer than 150mm to an opening in the building fabric formed for the purpose of accommodating a built-in element such as a window.
- 2) Dimension B,C and D; These clearances may be reduced to 25 mm without affecting the performance of the boiler. In order to ensure that the condensate plume does not affect adjacent surfaces the terminal should be extended as shown in Fig 7.4.
- 3) Dimension F; This clearance may be reduced to 25 mm without affecting the performance of the boiler. However, in order to ensure that the condensate plume does not affect adjacent surfaces a clearance of 300 mm is preferred.
- 4) BS 5440-1 It is recommended that a fanned flue terminal should be positioned as follows:
 - a) at least 2m from an opening in a building directly opposite, and
 - b) so that the products of combustion are not directly directed to discharge across a boundary.

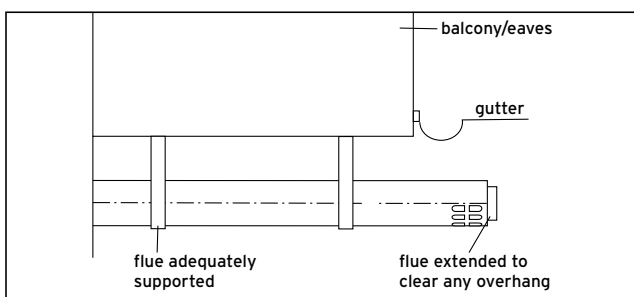

Fig. 7.4

7.3 Internal Flue Installation

The flue can be installed from inside the building when access to the outside wall face is not practicable.

7.4 Flue Options

There are various flue systems to choose from, as follows:

- Vertical air/flue duct and terminal 303 900
 - Air/flue duct extension (470 mm) 303 902
 - Air/flue duct extension (970 mm) 303 903
 - Air/flue duct extension (1970 mm) 303 905
 - Telescopic air/flue duct extension (440 mm - 690 mm) 303 906
 - 87° elbow 303 910
 - Two 45° bends 303 911
 - Standard horizontal air/flue duct with elbow and terminal (800 mm) 303 930
- Additional accessories are available.

8 Installation Preparation

8.1 Unpacking of Boiler

Stand the boiler carton upright. Cut and remove the securing straps and lift off the carton sleeve. Place aside the flue adaptor and connections pack until required. Carefully lay the boiler on its back, remove the two front casing panel securing screws and lift off the panel from two retaining lugs, see diagram 8.1. Remove the two inner casing panel securing screws at the bottom front of the panel, then lift off the two retaining lugs, see diagram 8.2.

8.2 Using boiler template

Fix the paper template to the wall ensure that the template is vertical. The template shows

- The position of the fixing holes for the boiler mounting bracket (1).
- The position of the connections.
- The position of the flue exit hole.

Mark the position of the top hanging bracket fixing holes. Drill 2 holes to accept the wallplugs/screws supplied for the hanging bracket.

Note!
Use alternative fixing holes where necessary.

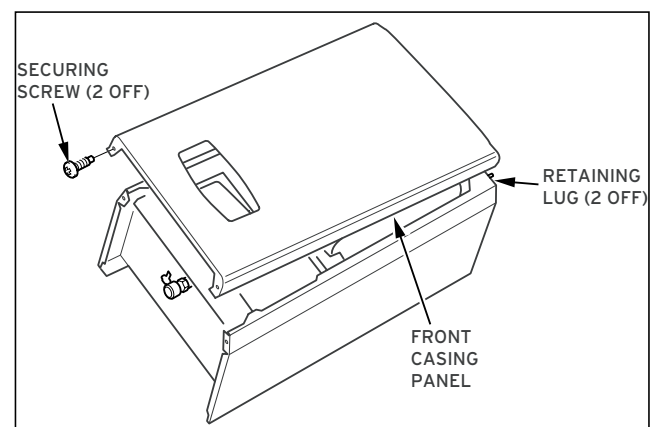

Fig. 8.1

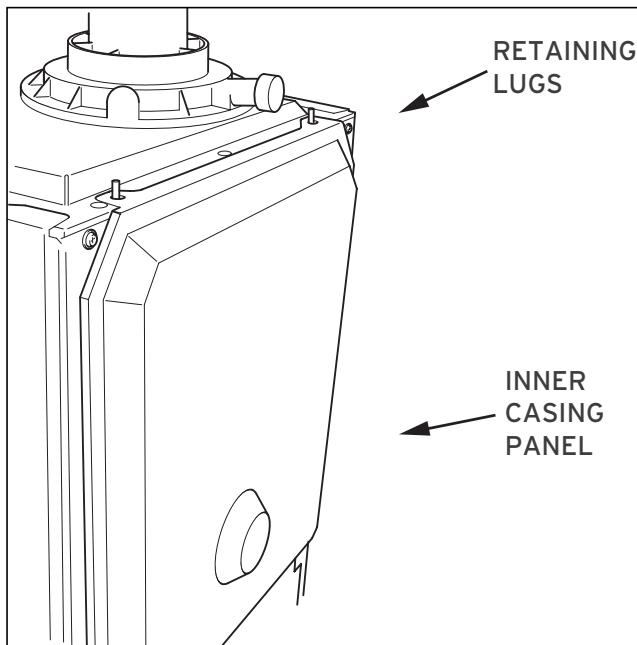

Fig. 8.2

8.3 Rear flue exit

Mark the position of the air/flue duct and its circumference.

8.4 Other flue options

Flue instructions for other flue systems such as vertical RSF flues, flues run to the side of the boiler and the use of additional bends etc. are detailed in the flue installation instructions.

Remove the template from the wall and plug the drilled holes using the wallplugs supplied.

8.5 Flue Hole Cutting

The standard horizontal flue is designed with an internal fall of 50 mm (± 20 mm) /metre towards the boiler for disposal of condensate.

If the standard flue length alone is being used then the flue hole can be cut in the position marked on the wall template.

For installations with external access, a 107 mm diameter core drill can be used.

For installations with internal access only, a 127 mm diameter core drill should be used.

For extended side flues, the flue hole centre should be determined by extending the dashed incline line on the template to the side wall. This dashed line is drawn at a 50 mm/metre (3°) rise from the boiler. Where this line reaches the side wall, a horizontal line should be marked. The vertical centre line of the flue should then be marked at 176 mm from the back wall, see Fig. 8.3.

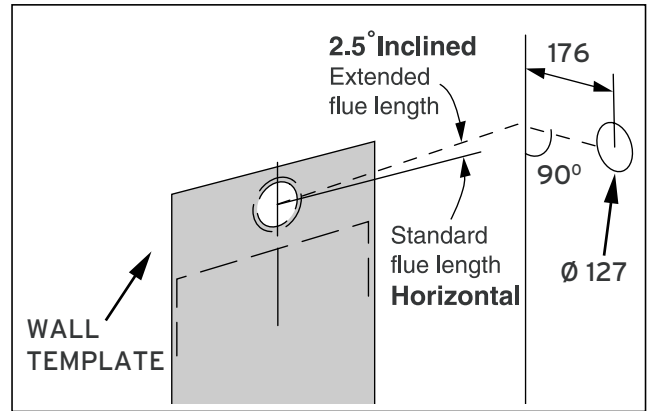

Fig. 8.3

To allow for the flue passing through the wall at this angle a 127 mm hole should be drilled irrespective of internal or external installation. If necessary remove the template whilst drilling the flue hole.

9 Boiler fixing

9.1 Fitting the boiler hanging bracket

Fix the hanging bracket to the wall using the screws supplied. (it may be necessary to use additional or alternative fixings to ensure adequate support).



Note!

If the boiler is to be fitted in a timber framed building ensure that the bracket is secured to a substantial part of the timber frame capable of taking the weight of the boiler.

9.2 Boiler Fixing

Having previously secured the hanging bracket to the wall, lift the boiler into position in the following manner: Lean the top of the boiler slightly to the wall and position just above the hanging bracket. Allow the boiler to slowly move downwards until engaged in the hanging bracket.

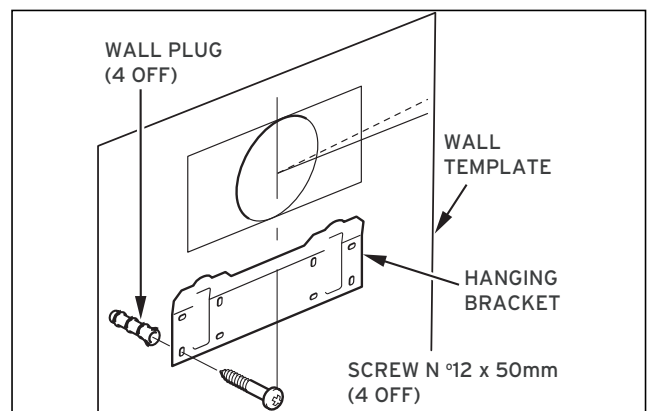

Fig. 9.1

10 Gas, Water and Condensate Connections

10 Gas, Water and Condensate Connections

10.1 Gas Connection

Before connection check the supply of local gas. The gas supply can be connected from below, or through the wall at the rear of the boiler. Ensure the supply pipe is fully engaged in the compression fitting on the gas service valve inlet. See Fig. 10.1. and refer to section 4.3.

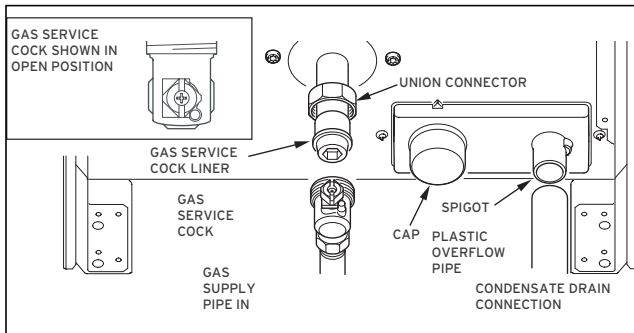

Fig. 10.1

10.2 Water Connections

Provision is made for the water connections to be made from above the boiler, see Fig. 10.2 (using the two 22mm compression couplers supplied). The position is shown on the wall template. Flush out the domestic hot water and the heating systems before connecting to the boiler.

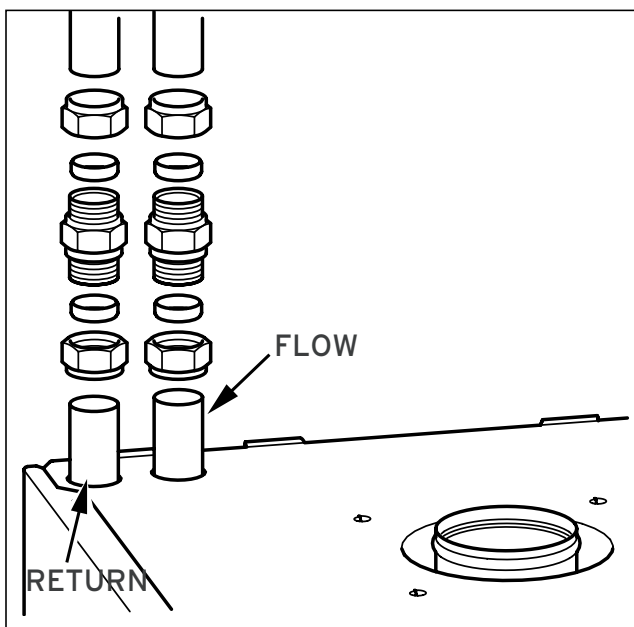

Fig. 10.2

10.3 Condensate Drain Connection

The condensate drain connection is at the rear of the boiler, see Fig. 10.1. A 21.5 mm plastic overflow pipe should be connected to the spigot on the condensate trap (using the coupler). The drain pipe should have a fall of at least 2.5° away from the boiler. Condensate should, if possible be discharged into the household internal drainage system. If this is not practicable, discharge can be allowed into the external household drains or a purpose designed soak away.

It is recommended that any external condensate drain pipe is insulated and also preferably of 32mm diameter, to prevent freezing in adverse weather conditions. The condensate is discharged periodically in 'slugs' by siphonic action. It is not necessary to provide air breaks or extra traps in the discharge pipe, as there is already a trap inside the boiler. Refer to BS 6798 for advice on the disposal of the boiler condensate.

11 Flue Preparation and Installation

11.1 Flue Length

All dimensions are in mm.

To determine flue length, temporarily fit flue elbow to top of boiler.

For rear or side flue, measure the distance from the outside wall to the butt joint of the flue elbow fitted on top of the boiler. A standard flue system will be suitable if the length measured 'Y' is less than 633 mm, see Figs. 11.1 and 11.2.

If the measurement 'Y' exceeds 633 mm then one or more extension pipes are required.

When cutting, the flue duct should protrude 13 mm from the end of the air duct.

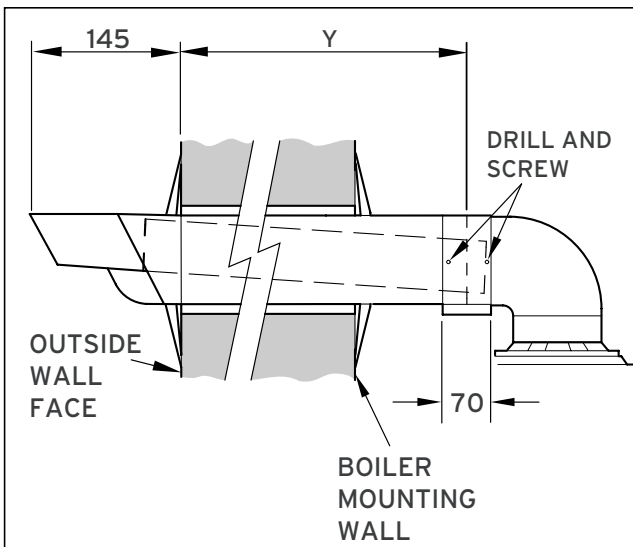

Fig. 11.1 Rear flue

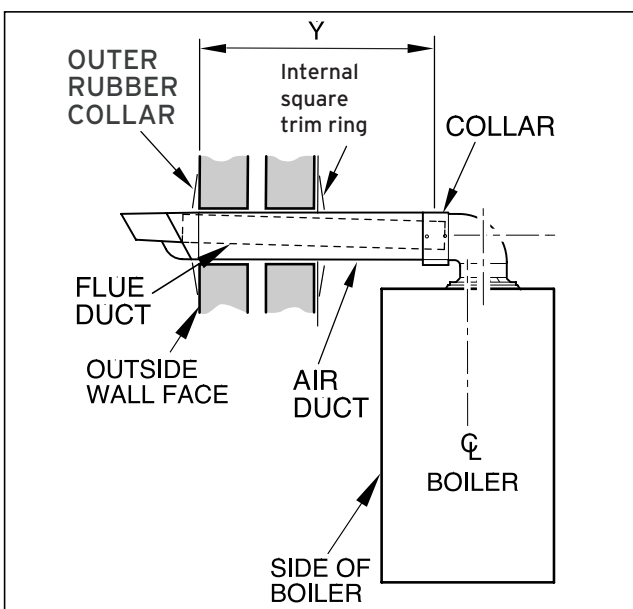

Fig. 11.2 Standard side flue

11.2 Extension pipes

Refer to Figs. 11.3 and 11.4.

Note maximum permitted flue lengths.

When extension pipes are required please note the length of the extensions, which should be taken into account when calculating the length that requires cutting.

For example:

Distance from outside wall to butt joint on the flue elbow 'Y' = 1500 mm.

Standard flue length = 633 mm.

Extension pipe length = 970 mm.

Length of extension pipe air duct = 1500 - 633 = 867mm.

In this example the extension pipe would be cut to 867 mm, this would be measured from the end of the air duct where the flue duct contains the 'o-ring' seal.

When cutting, the flue duct should be cut to protrude 13 mm from the end of the air duct at the opposite end to where the flue duct contains the 'o-ring' seal.

The maximum permitted straight flue length is 10 metres plus the standard horizontal flue. For each 90° elbow or pair of 45° bends fitted, the maximum length must be reduced by 1 metre.

Note!
When using elbows/bends any horizontal extension pipe should be inclined by $3^\circ \pm 1^\circ$ fall towards the boiler to facilitate condensate removal.

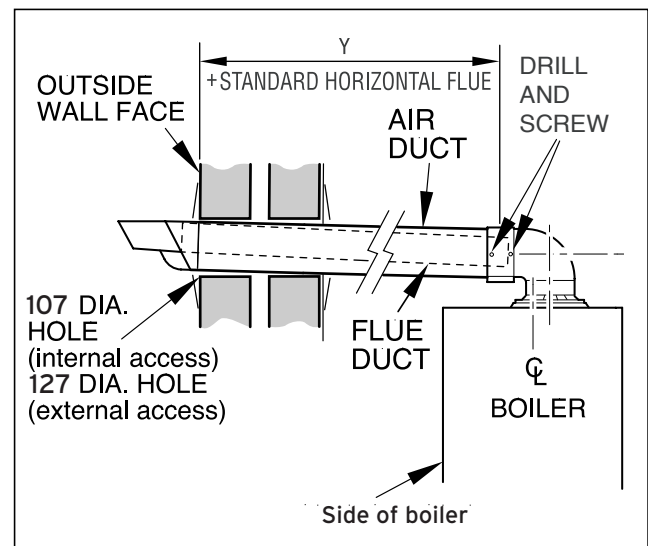

Fig. 11.3 Side flue extension

11 Flue Preparation and Installation

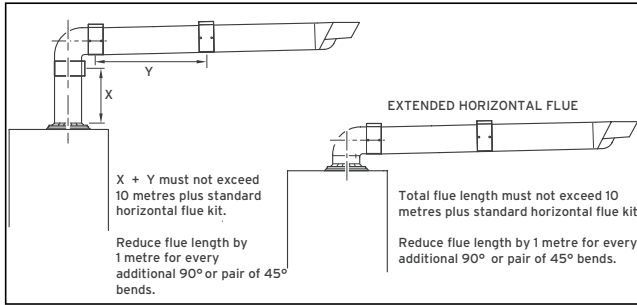

Fig. 11.4 Elevated horizontal flue

11.3 Flue Assembly

The flue assembly is a push fit design with securing collars.

Remove all burrs from cut pipes.

Fig. 11.5 shows the components supplied in the standard kit and the flue adapter.

Having cut the air and flue ducts as described in sections 11.1- 11.2 assemble the flue as follows, the flue can be fitted externally or internally.

Fit the rubber sealing collar behind the locating lugs on the flue terminal, see diagram 11.5. Push the flue assembly into the wall, externally or internally, initially until the end of the assembly protrudes a short way from the inside face of the wall. This will enable the internal square trim ring to be positioned and allow the flue duct to be drawn into the flue elbow after the flue adapter has been fitted.

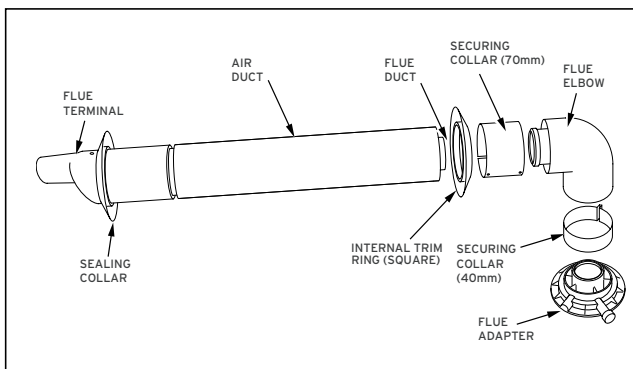

Fig. 11.5

11.4 Flue Attachment To Boiler

Lubricate the internal rubber seal of the flue outlet on the boiler with a suitable lubricant. Secure the flue adapter in position on top of the boiler with the four screws supplied, making sure the nib fits into the locating slot in the boiler casing to ensure correct orientation.

Fit the flue elbow with the securing collar (length 40 mm) on to the flue adapter.

Secure the flue elbow by tightening the two screws on the securing collar.

Draw flue assembly from wall, fit securing collar (length 70 mm), slide flue duct into flue elbow.



Note!

If the air and flue ducts have been correctly cut to the instructions given in sections 11.1-11.2 the rubber sealing collar should fit flush with the outside wall.

Position securing collar centrally over joint, tighten securing screws. Drill and insert four self-tapping screws, supplied, in the holes provided in the securing collar.

Secure internal trim ring in position with a small amount of sealant.

12 Electrical Connections

Warning!
 **This boiler must be earthed.**

All system components must be of an approved type. Electrical components have been tested to meet the equivalent requirement of the BEAB.

Connection of the whole electrical supply must be through a common isolator.

Isolation should preferably be by a double pole switched fused spur box having a minimum contact separation of 3mm on each pole. The fused spur box should be readily accessible and preferably adjacent to the boiler. It should be identified as to its use. A fused three pin plug and shuttered socket outlet may be used instead of a fused spur box provided that:

- They are not used in a room containing a fixed bath or shower.
- Both the plug and socket comply with the current issue of BS1363.

Do not interrupt the mains supply with a time switch or programmer.

Warning!
 **This appliance must be wired in accordance with these instructions. Any fault arising from incorrect wiring cannot be put right under the terms of the Vaillant guarantee.**

12.1 Mains, external controls and pump connections (mains voltage)

ecoMAX pro boilers are fitted with a terminal box located at the base of the boiler into which all connections are made.

To gain access to the terminal box remove the two retaining screws indicated in Fig. 12.1 and carefully lower to reveal the terminal strip inside.

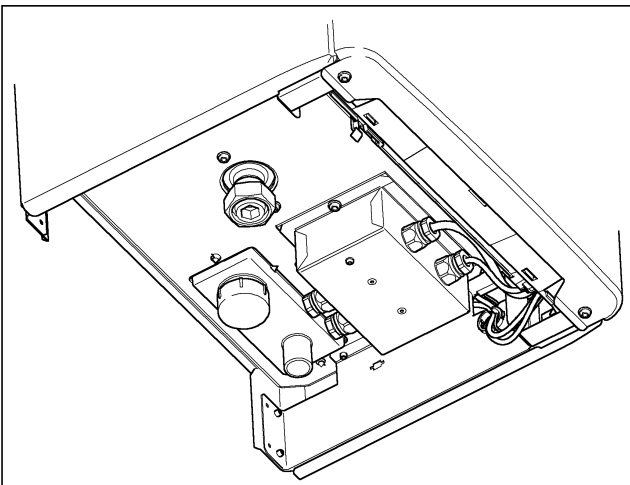

Fig. 12.1

Disconnect and remove the test cable from the terminal strip and discard.

Connect both the mains supply and switched live from the external controls (room thermostat and, if applicable, frost thermostat) into the marked terminals as shown in Figs. 12.2 and 15.1.

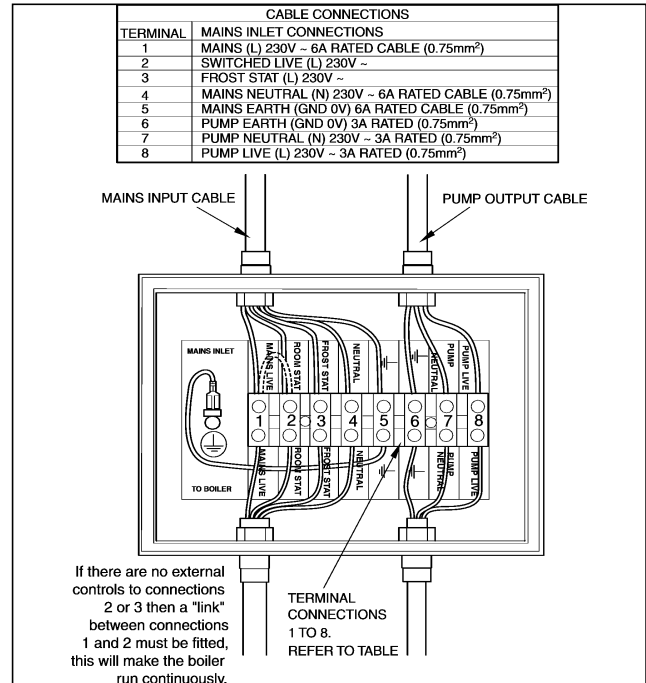

Fig 12.2

Connect the pump supply into the marked pump terminals as shown in Figs.12.2 and 15.1.

(Note: the boiler incorporates a pump overrun thermostat. Only feed the pump from the marked terminals in the terminal box on the boiler, not from a separate supply).

Observe all terminal markings and colour codes shown in Fig. 15.1.

Ensure that all flexible cords are routed through the strain relief cable glands on the inlet of the terminal box.

Refit the terminal box to the underside of the boiler using the two retaining screws.

12.2 Electrical connections - testing

Carry out preliminary electrical system checks as below;

- Test insulation resistance to earth of mains cable.
- Test the earth continuity and short circuit of cables.
- Test the polarity of the mains.

13 Commissioning

13.1 Preliminaries - All Systems

A competent person in accordance with the current issue of BS 6798 should carry out commissioning.

Preliminary electrical checks

Check the electrical installation by carrying out short circuit, earth continuity and resistance to earth tests and a check for correct polarity.

Make sure that the system has been thoroughly flushed out with cold water.

Refill the system with water, making sure that all the air is properly vented from the system and pump, Fig. 13.1 shows vent point.

Before operating the boiler check that all external controls are calling for heat.

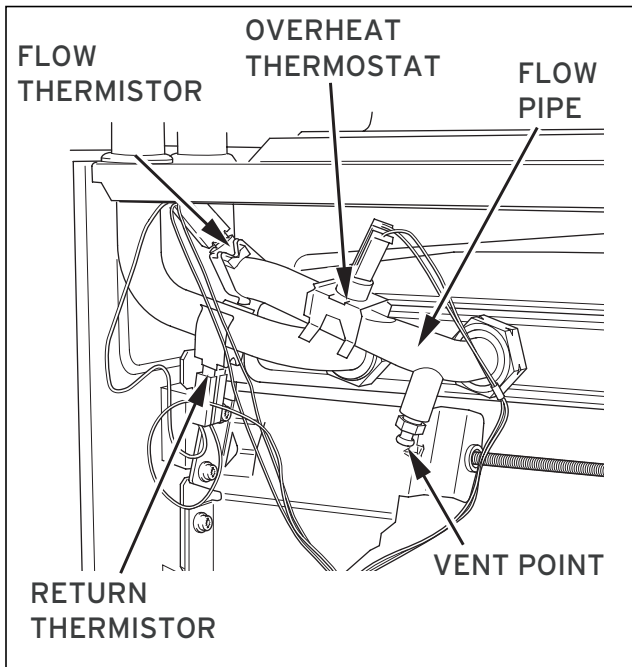

Fig. 13.1

13.2 Sealed Systems

Fill the system until the pressure gauge registers the recommended pressure. Clear any air locks and check for leaks.

Check the operation of the safety valve, preferably by allowing the water pressure to rise until the valve lifts. This should be within ± 0.14 bar, of the preset pressure. Where this is not possible a manual check should be carried out.

Release the cold water to the initial design pressure.

13.3 Gas supply

Isolate the boiler from the mains electrical supply.

The complete gas installation including the gas meter must be inspected, tested for soundness and purged in accordance with BS 6891.

The gas supply to the boiler can be purged by slackening the gas service valve beneath the boiler.

Ensure that there is adequate ventilation, extinguish all naked flames and do not smoke whilst purging.

After purging, the gas service valve connection must be retightened and tested for soundness. (The boiler itself does not require purging as this will be done by the automatic burner sequence control).

13.4 Initial Lighting

The lighting procedure of the boiler is fully automated. To prepare the boiler for initial lighting first ensure that all external controls are not calling for heat.

With the front casing panel and inner casing panel removed turn on the mains electrical supply. Slide the On / Off control down to the I position to turn on the boiler. The operating indicator will illuminate (green) to show that the boiler is on.

Now adjust the boiler thermostat to its lowest setting by pushing the mode button (see Fig. 3.1.) until the radiator symbol is displayed. Push the - button until the lowest temperature possible is selected. Now return to the normal mode by pushing the mode button, the display will now show the current temperature of water in the boiler.

Now turn on external heat demand to boiler. The fan should start and after a few seconds the ignition will commence.



Note!

Allow the boiler to run on minimum until commissioning is complete.

If the burner fails to light the fan will stop. Initially this may be due to air in the gas supply line.

The boiler will have three attempts at ignition.

To reset the boiler slide the On / Off control to the Off (O) position and after 5 seconds back to the On (I) position. The boiler should now restart.

Once the boiler has lit, allow the system to warm at the minimum temperature setting to purge any air from the system.

Once the system has been purged of air, the temperature of the central heating water can be adjusted to the desired setting by pushing the mode button (see Fig.3.1.) until the radiator symbol is displayed. Pushing the + or - buttons will then set the water temperature as desired. (Typical setting temperatures for a normal radiator heating system will be in the range of 60 °C to 80 °C. Note that set temperatures below 60 °C will not sufficiently heat any hot water cylinder). To return to the normal mode push the mode button () until the display shows the current temperature of water in the boiler.

The boiler will then continue to fire until the user controls are satisfied.

Note: After the first power up the firing sequence changes. After one minute stabilisation time the boiler will ramp slowly to full rate rather than going immediately to full rate, this feature is designed to cope with small system requirements.

13.5 Testing - Gas

The boiler is supplied ready adjusted and no further gas adjustments are necessary, however both the gas inlet working pressure and the maximum gas rate should be checked at least 10 minutes after the burner has lit.

The gas inlet working pressure can be checked at the pressure test point on the gas valve (Fig 13.2.). The gas inlet working pressure should be 20 mbar when the boiler is firing at full rate.

After testing the inlet pressure remove the U gauge, tighten the sealing screw and test for tightness.

The approximate gas rates are:

18 E : 1.81 m³/h

28 E : 2.7 m³/h

Note: The burner pressure cannot be measured at the gas valve due to the fan/burner design.

Replace the inner and front casing panels.

Record appliance working gas inlet pressure (mbar) in Benchmark Installation, Commissioning and Service log book.

13.6 Testing - Heating System

Check that all remote controls are calling for heat. The boiler will fire automatically. Fully open all radiator valves, flow control valve 'A' and bypass valve 'B' if fitted, see Fig. 5.4.

Balance the radiators as required and if fitted adjust valve 'A' to give the required system differential. Turn off all radiators that can be shut off by the user and check to see if less than the maximum differential allowed of 20 °C can be achieved across flow and return.

Allow the system to reach maximum temperature then switch off the boiler by isolating from the electrical supply.

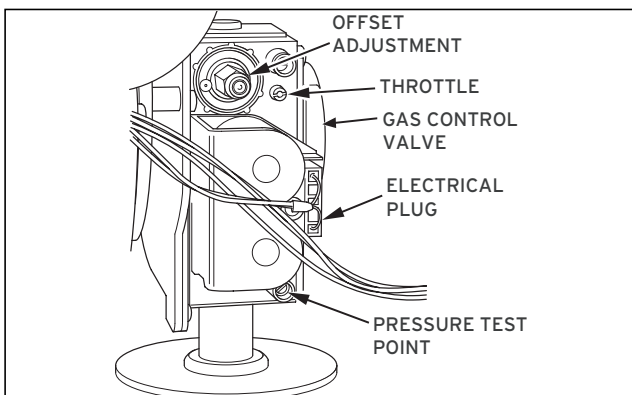

Fig. 13.2

Drain the entire system rapidly whilst hot, using the drain tap at the lowest part of the system. Fill and vent the system as described previously.

Lock or remove the handles from controls valve 'A' and bypass valve 'B' to prevent unauthorised adjustment.

13.7 User Controls and Options

The mains/reset switch is used to restart the boiler after a fault condition has occurred, i.e. ignition failure.

The user display (see section 3.3) allows the user to set the desired central heating temperature.

13.8 Temperature Display

The boiler shows the operating temperature of the unit.

13.9 Pump Exercise Programme

After a power cut or every 24 hours in frost setting/summer mode the pump will run for one minute to prevent it from sticking. This will also occur during normal operating if there is no demand for more than 24 hours.

13.10 Handover to user

Instruct and demonstrate the lighting procedure and advise the user on the safe and efficient operation of the boiler. Instruct on and demonstrate the operation of any heating system controls.

Advise that to ensure the continued efficient and safe operation of the boiler it is recommended that it is checked and serviced at regular intervals. The frequency of servicing will depend upon the installation conditions and usage, but in general, once a year should be adequate.

Draw attention, if applicable, to the current issue of the Gas Safety (Installation and Use) Regulations, Section 35, which imposes a duty of care on all persons who let out any property containing a gas appliance.

It is the Law that any servicing is carried out by a competent person.

Advise the user that, like all condensing boilers this appliance will produce a plume of condensation from the flue terminal in cool weather. This is due to the high efficiency and hence low flue gas temperature of the boiler.

Advise the user of the precautions necessary to prevent damage to the system, boiler and the building, in the event of the heating system being out of use during frost or freezing conditions.

Advise the user that the permanent mains electrical supply **SHOULD NOT** be switched off, as the built in frost protection and pump saver program would not be operable.

Reminder, leave these instructions and the 'Benchmark' logbook with the user.

14 Servicing

14.1 General

Measurement of the products of combustion can be achieved by connection of a probe to the combustion analyser test point on the flue adaptor, see Fig. 14.4. Refer to section 14.7 and data table.

Before commencing with a service or replacement of parts the boiler should be isolated from the electrical supply and the gas supply should be turned off at the gas isolation valve, see Fig. 14.2.

All routine servicing requirements can be achieved by the removal of the front panel, inner panel and chassis front only.

Remove the two screws on the underside of the front panel and lift off. Undo the two screws on the front of inner panel and lift off, see Fig. 14.7.

To remove chassis front, refer to section 14.3.

Unless stated otherwise any part removed during servicing should be replaced in the reverse order to removal.

Servicing should always include the removal of any debris from the condensate pipe and siphon.

After completing any servicing of gas carrying components, ALWAYS test for gas soundness and carry out a functional test of the controls.

14.2 Spark Electrode

Disconnect the ignition lead and earth lead from the ignitor unit and two securing screws at the spark electrode. Withdraw the spark electrode carefully from the combustion chamber, see Fig. 14.1.

Inspect the tips for damage.

Clean away any debris and check the spark gap is 3.5 - 4.5 mm.

Check the electrode gasket for signs of damage and replace if necessary.

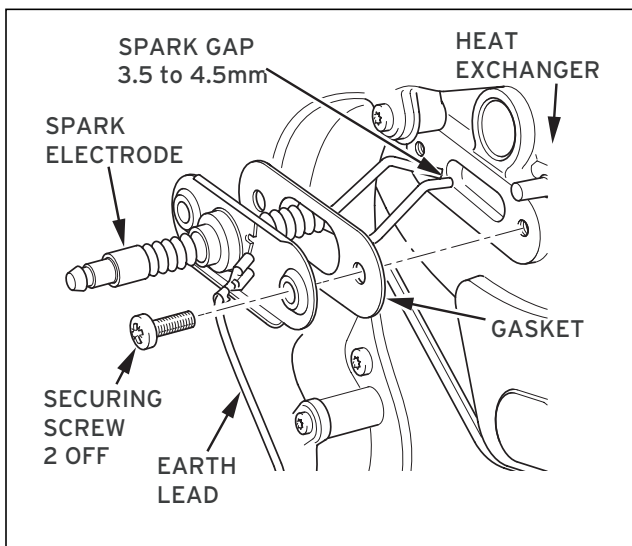

Fig. 14.1

14.3 Burner

Refer to Figs. 14.2, 14.3, 14.4 and 14.5.

Isolate the gas supply at the gas service cock.

Disconnect the gas supply at the gas service cock.

Note!

Do not disconnect at the gas valve.

Remove the two gas pipe bracket securing screws from underside of inner case, see Fig. 14.2.

Drop down the control panel into the service position.

Remove the four screws from the chassis front, see Fig. 14.3.

Remove the chassis front by pulling it out at the top from its retaining slots.

Note!

When replacing chassis front panel ensure the bottom fits behind lip.

Disconnect the gas control valve plug at the gas control valve, see Fig. 14.4.

Disconnect the electrical leads from the fan.

Remove the five combustion chamber front securing nuts, see Fig. 14.5.

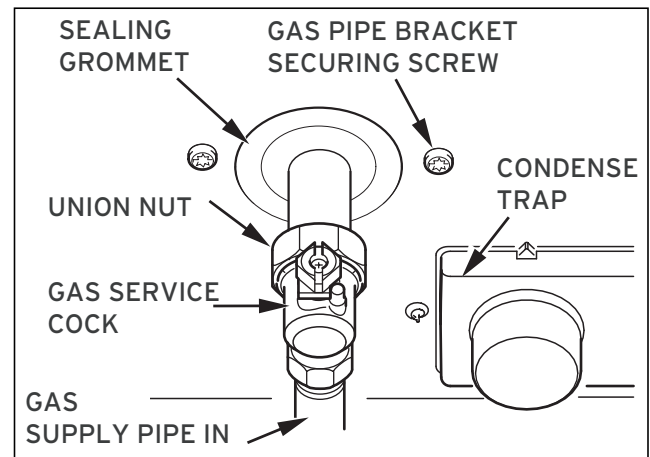

Fig. 14.2

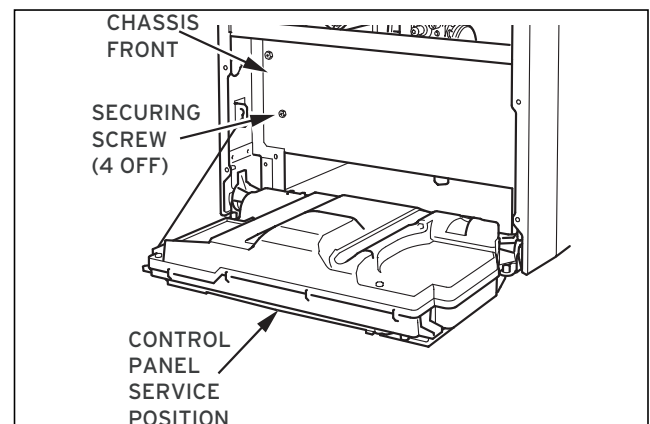

Fig. 14.3

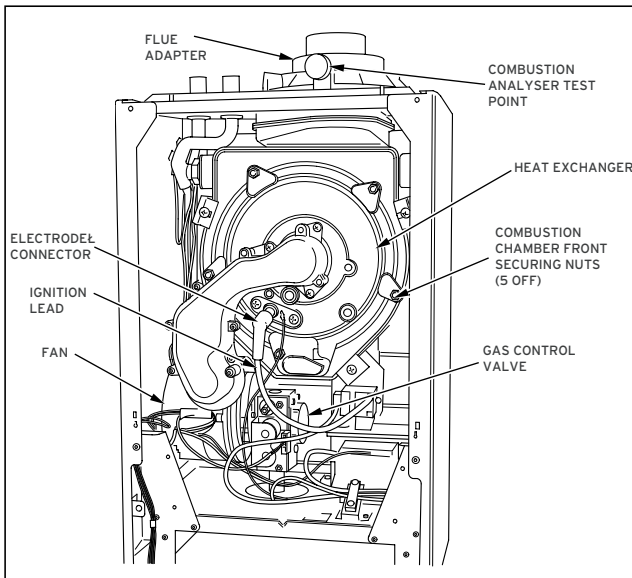

Fig. 14.4

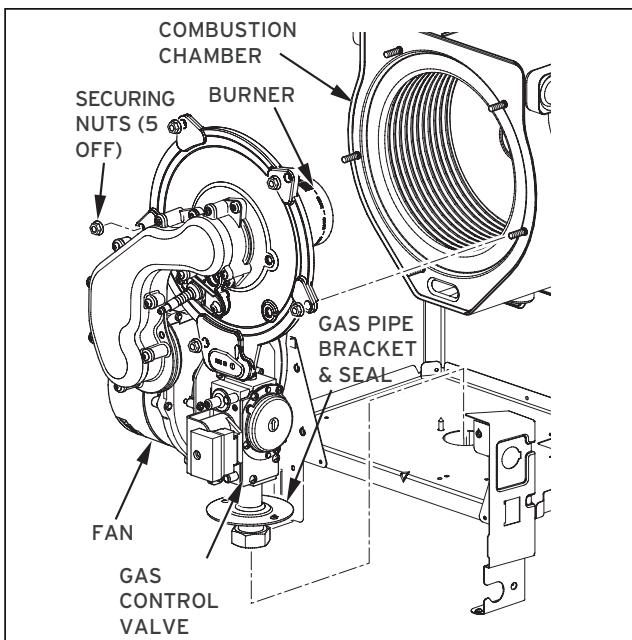

Fig. 14.5

Gently remove the fan, gas control valve and burner assembly from the combustion chamber complete with the gas pipe bracket and seal.
 Clean the burner with a soft brush taking great care not to damage the front insulation. DO NOT use wire or sharp instruments to clean the holes of the burner. Inspect the burner for any signs of damage.
 Removal of the burner is not necessary during a normal service.

Note!
 If the burner has to be removed it will require a new gasket when refitted.

When replacing the assembly ensure the sealing grommet is correctly fitted.

14.4. Combustion Chamber and Heat Exchanger.

Refer to Fig. 14.2.

Remove loose debris from combustion chamber using a soft brush and vacuum cleaner. Carefully flush any remaining debris through the condensate trap (ensure the water is kept away from electrical components).

14.5 Condensate Drain

Refer to Fig. 14.5.

Remove DC fan supply.
 Remove the clips securing the flexible tubes to the siphon adapter by twisting the clips slightly to disengage the clip jaws from each other.
 Remove black flexible tubes from siphon adapter.
 Lift off the siphon adapter.
 Remove the drain connection downstream of the condensate trap.
 Remove the two condensate trap securing screws. Lift up and carefully remove the condensate trap taking care not to spill any water which may be left in the unit. As the unit is lifted remove the flexible pipe on the outlet.
 Remove the cap at the base of the condensate trap.
 Remove any solids found.
 Remove the float to clean it.
 Flush water through the trap to remove any remaining solids.
 Check for any debris in the outlet pipe of the condensate drain and clean as necessary.
 Reassemble and refit the condensate trap.
 When refitting the cap ensure that a watertight seal is achieved, but do not use excessive force.
 Remove the siphon adaptor from the silicone tubes, using a suitable container, flush the heat exchanger until the water appears clear in the container.

14.6 Inner Casing Panel Seal Check.

Refer to Fig. 14.7.

Check the condition of the seal, replace as required.
 To replace remove the old seal, thoroughly clean the casing surfaces. Fit the new seal, it is supplied to the correct length.

14 Servicing

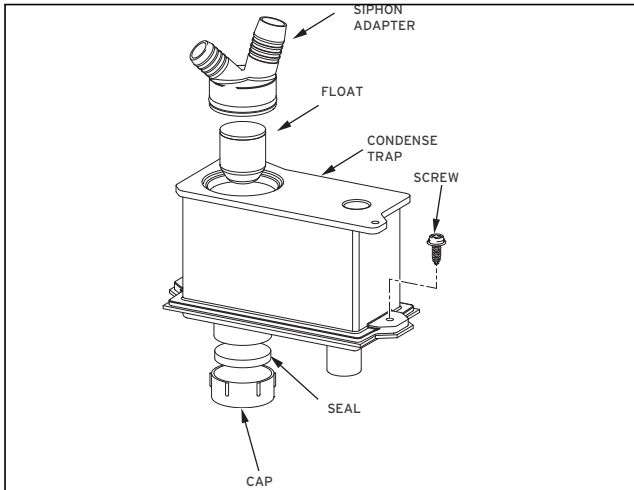

Fig. 14.6

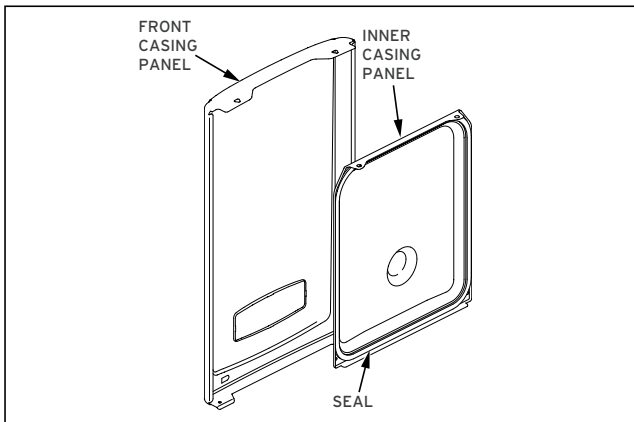

Fig. 14.7

15 Fault Finding

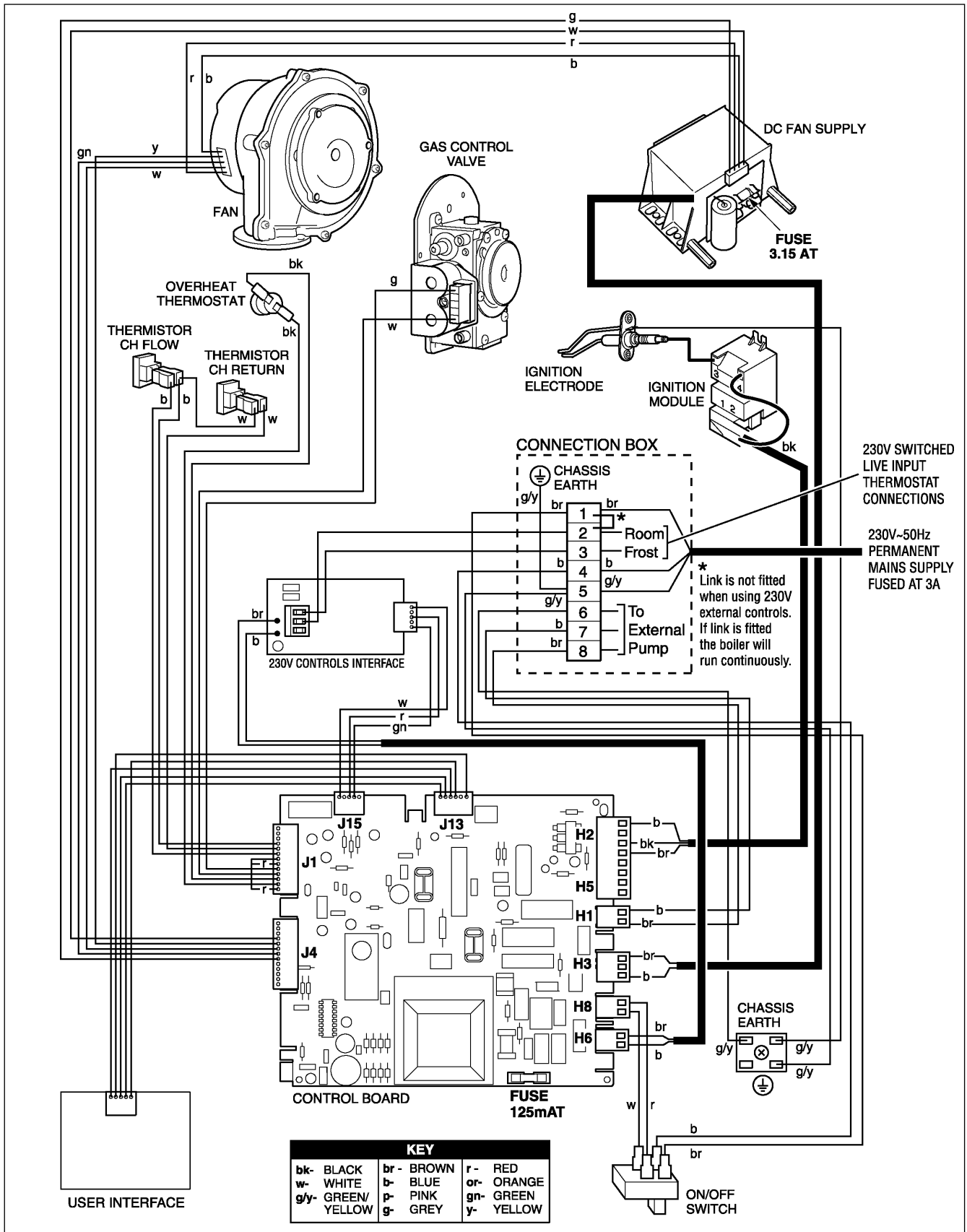

Fig. 15.1

15 Fault Finding

15 Fault finding

Logical fault finding procedure

These checks must be carried out before attempting to use the fault finding guide.

1. Carry out electrical safety checks (see section 'preliminary electrical checks' 13.1)
2. Check that the external electricity supply to the boiler is on, and a supply of 230V is present at the boiler terminal strip
3. Check that the gas supply to the boiler is on, that it has been correctly purged and that an inlet pressure of 20mbar is available at the gas valve (see section 'gas supply' 13.3)

4. Ensure the heating system is full of water and charged to between 1 and 1.5 bar, on sealed systems
5. Check that the main on/off control is set to the 'on' position
6. Set the central heating temperature to maximum
7. Check that all external controls are on and calling for heat
8. Check that all manual circuit controls ie. bypass, radiator valves are correctly adjusted

Fault codes

Fault codes take priority over all other display functions in the event of a system fault occurring.

code	description	comment
F1	Ignition fault (lockout) Failed to light	No gas; Insufficient gas; Incorrect gas valve adjustment; Electrode defect; Ignition lead defect; Electronic igniter defective; Check air inlet duct; Check connections to igniter unit
F4	Ignition fault (lockout) Went out when lit	As above
F5	Overheat fault	Overheat stat operated; Maximum temperature exceeded; Check thermistor connections; Air in system with thermistor at maximum setting; Faulty overheat stat connection; Check that pump is wired into appliance and not from programmer. This would cause no pump overrun
F6	Central heating flow NTC fault	Flow NTC cable defective/broken NTC faulty Flow thermistor not fitted correctly
F10	Central heating return NTC fault	Return NTC cable defective/broken NTC faulty Check that thermistor attached correctly to pipe.
F11	No reception by main board	Connection fault between main PCB and interface; Faulty interface; Faulty main PCB (processor)
F12	No reception by the local user interface	As F.11
F13	Main board fault	As F.11
F14	Central heating flow $t^{\circ} > 95^{\circ} C$	System fault; Possible external pump failure; Check NTC on flow Check that pump is wired into appliance and not from programmer. This would cause no pump overrun
F16	Flame detection fault (flame presence >5 s after burner stop)	Gas valve defective
F17	Power supply <170 V	Check electrical supply / polarity
F18	Local user interface fault	Connections; Faulty interface
F19	Central heating NTC unplugged	Check NTC connection
F20	MMI software incompatible with IRIS software	Possible connection fault
F24	Central heating return $t^{\circ} > 90^{\circ} C$	System fault; Possible external pump failure; Check NTC on return; Check that pump is wired into appliance and not from programmer. This would cause no pump overrun.
F25	Maximum temperature rise slope	Possible external pump failure; Air in system restricting movement of water. Insufficient circuit flow
F26	Maximum delta t	Check NTC on return; System fault - too restrictive?; Possible pump failure

16 Short Spare Parts

Key No.	Part No.	Description
1	190260	Fan assembly
2	090750	Spark electrode
3	091258	Igniter unit
4	053574	Gas control valve
5	101771	Heating flow & return NTC (2)
6	101191	Overheat stat
7	130837	Control box P.C.B.
8	287452	DC Fan supply
9	256271	Mains/Reset Switch
10		User interface/Display Unit PCB
11	050469	Burner - 18 E
11	050470	Burner - 28 E
12	256275	230V Controls Interface

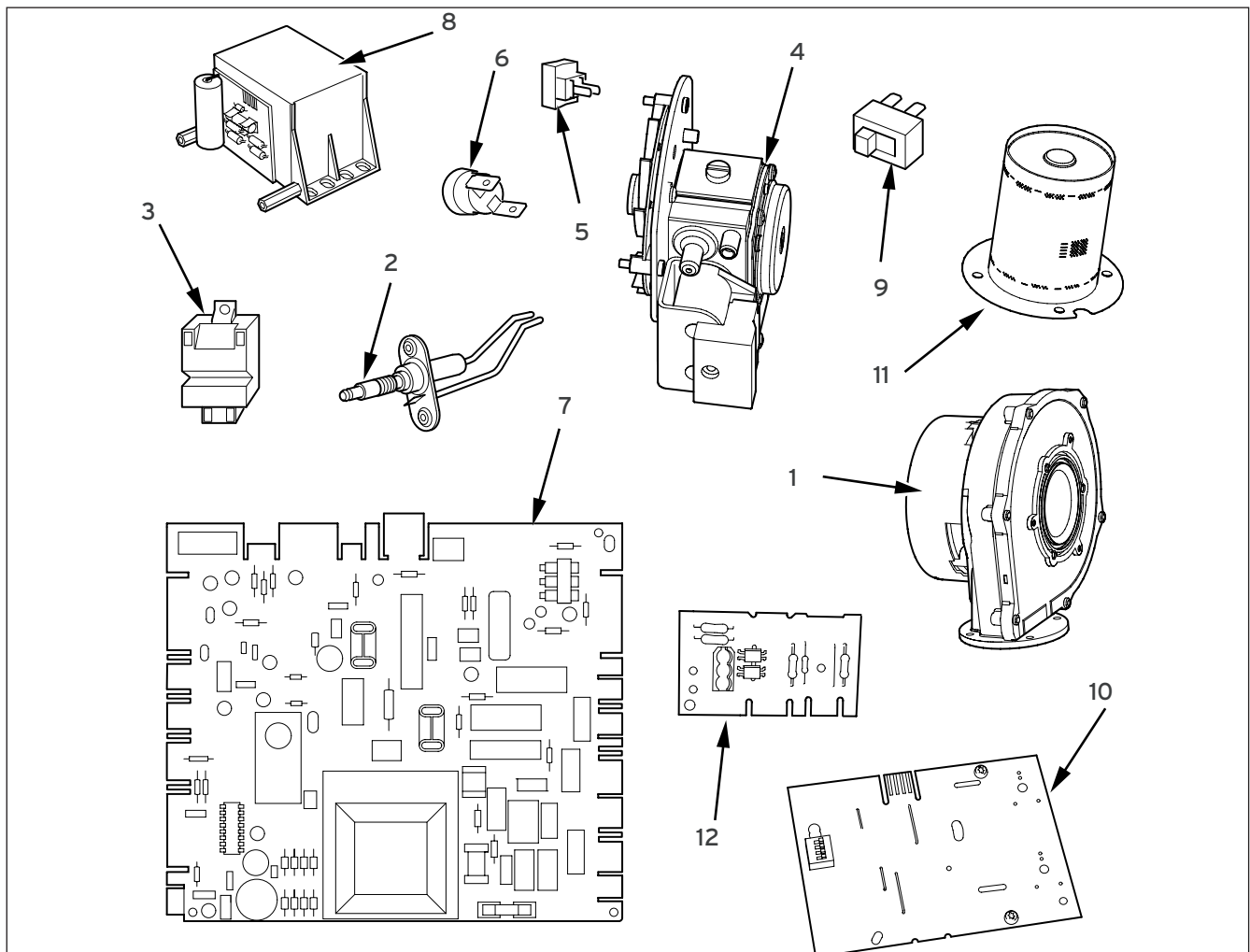

Fig. 16.1

17 Boiler Specification

17 Boiler Specification

	ecoMAX pro 18 E	ecoMAX pro 28 E	Units
Maximum CH heat input (net)	18.6	28.6	kW
CH heat output (80/60 °C)	5.0 - 18.3	5.3 - 28.2	kW
CH heat output (50/30 °C)	5.3 - 20.0	5.7 - 30.6	kW
Maximum DHW heat input (net)	20.02	30.58	kW
SEDBUK Band	A	A	
SAP Seasonal Efficiency	90.4	90.6	%
NOx Class	5	5	
Electrical rating	IPX4D	IPX4D	
Inlet gas working pressure required (natural gas)	20	20	mbar
Gas supply (G20) Gross CV (s.t.)	37.8	37.8	MJ/m ³
Maximum gas rate	1.81	2.7	mbar
Minimum gas rate	0.48	0.52	mbar
Burner % CO2	9.0 +/-0.2	9.0 +/-0.2	%
Gas connection	15 mm Compression	15 mm Compression	
Water connections	22 mm Compression	22 mm Compression	
Condensate drain (internal diameter min.)	19	19	mm
Internal fuse ratings	Fan supply PCB 3.15 AT Main PCB 125 mAT	Fan supply PCB 3.15 AT Main PCB 125 mAT	A A
Maximum CH system pressure	3	3	bar
Weight	31	33	kg
Electrical supply	230/~50	230/~50	V~/Hz
External fuse	3	3	A
Power input	60	60	W
Case height	600	600	mm
Case width	375	375	mm
Case depth	334	334	mm

Head Office: Vaillant Ltd.

Vaillant House ■ Medway City Estate ■ Trident Close

Rochester ■ Kent ME2 4EZ

Service Solutions 0870 6060 777 ■ Technical Advice 01634 292392

ecoMAXpro_00 GB 10/2002 X · Subject to alteration