



For the owner

Instructions for use
ecoTEC



Wall hung room sealed fan assisted condensing boilers

THIS DOCUMENT HAS BEEN PROVIDED BY



heating spares
247.com

PLEASE VISIT WWW.HEATINGSPPARES247.COM FOR FURTHER
INFORMATION AND GENUINE PARTS & SPARES AT LOW PRICES

Contents

Specified use

1 Notes on these instructions

Specified use 2

1 Notes on these instructions 2

1.1 Storage of the documents 2

1.2 Symbols used in this manual 3

1.3 CE marking 3

1.4 Data badge 3

2 Safety 3

2.1 Setup and adjustments 3

2.3 Safety instructions 3

2.4 Modifications in and around the boiler 3

3 Instructions on operation 5

3.1 Factory guarantee 5

3.1.1 Two year guarantee for ecoTEC plus and three year guarantee for ecoTEC exclusive boilers 5

3.1.2 One year guarantee for ecoTEC pro boilers 5

3.1.3 Registering with us 5

3.1.4 Immediate help 5

3.2 Intended use 5

3.3 Care 5

3.4 Recycling and disposal 5

3.4.1 The appliance 5

3.4.2 Packaging 5

4 Operation 6

4.1 Overview of controls on ecoTEC plus and ecoTEC exclusive 6

4.2 Overview of controls on ecoTEC pro 7

4.3 Initial checks before turning on 7

4.3.1 Opening the service valves 7

4.3.2 Checking the system pressure 8

4.4 Turning the boiler ON 9

4.5 Domestic hot water with ecoTEC combination boilers 9

4.5.1 Setting the water temperature 9

4.5.2 Switching the warmstart function on and off ... 9

4.5.3 Drawing hot water (ecoTEC combination boilers only) 10

4.6 Heating operation 10

4.6.2 Switching off heating (summer operation) 11

4.6.3 Setting a room- or outside temperature controller 11

4.7 Status displays 11

4.8 Troubleshooting 12

4.8.1 Problems due to low system water pressure 12

4.8.3 Flue problems 12

4.9 Turning off the boiler 12

4.10 Frost protection 13

4.11 Maintenance and customer service 13

2 Specified use

The Vaillant ecoTEC plus, ecoTEC pro and ecoTEC exclusive models are compact, wall-mounted condensing boilers. ecoTEC plus and pro combination boilers provides both central heating and domestic hot water, with the domestic hot water supplied directly from the boiler. The boiler will operate automatically to provide domestic hot water whenever a hot water tap is opened, and automatically adjusts to meet the demand for both central heating and domestic hot water in the most economical way. ecoTEC system boilers provides central heating and domestic hot water where a separate indirect hot water cylinder is also incorporated to the system.

1 Notes on these instructions

To ensure clarity of information in instructions a new European standard of advice and symbols is being introduced. To ensure compliance with this new standard the following details are included. The following information is intended to help you throughout the boilers entire instruction pack. We assume no liability for any damage caused by not following these instructions.

Other instruction supplied with this appliance

For the end user

Short operating instructions (ecoTEC plus and ecoTEC exclusive only)	no. 838404
Warranty card with return envelope	
2 years	no. 809222
1 year	no. 802961

For the installer/service engineer:

Instructions for installation and servicing - for ecoTEC plus and pro	no. 839592
- for ecoTEC exclusive	no. 0020017768
Flue installation instructions	no. 834449

The instructions for any accessories and controllers used also apply. The Benchmark gas boiler commissioning checklist (in the installation manual) should be completed by the installer and/or the commissioning engineer. If, after reading these instructions, you have any questions on the operation of the boiler, please contact either your installer or Vaillant Technical Department.

1.1 Storage of the documents

Please store this user manual and all related documents so that they are available whenever they are required. If you move please pass on the documents to the buyer.

1.2 Symbols used in this manual

Please observe the safety instructions in this operating manual for the operation of the appliance.



Danger!
Immediate risk of serious injury or death.



Caution!
Potentially dangerous situations for the product and environment.



Note!
Useful information and instructions.

- Symbol for a necessary task

1.3 CE marking

The purpose of CE marking is to certify that the boiler complies with the requirements of the directives covering gasfired appliances (Council directive 90/396/EEC) and electromagnetic compatibility (Council directive 89/336/EEC). These appliances also comply with the requirements of the directive on operating efficiency (Council directive 92/42/EEC).



Note!
Vaillant Ltd. support the Benchmark initiative. At the rear of the installation manual you will find the Benchmark gas boiler commissioning checklist. It is very important that this is completed correctly at the time of installation and commissioning.

1.4 Data badge

The type plate of the Vaillant ecoTEC is attached at the factory to the bottom of the appliance.

2 Safety

2.1 Setup and adjustments

Installation and adjustment of the boiler as well as service, maintenance and repair of the boiler may only be carried out by a competent person in accordance with the Gas Safety (Installation and Use) Regulations 1998. (In the U.K. "CORGI". Registered installers undertake the work to a safe and satisfactory standard). If the boiler is installed in a compartment do not obstruct any purpose provided ventilation openings, and do not use the compartment for storage purposes.

2.2 What to do in an emergency



Danger
Smell of gas. Risk of poisoning and explosion due to a malfunction

If you smell gas or suspect a gas leak:

- Do not switch lights on or off.
- Do not use any other electrical switches.
- Do not use a telephone in the hazardous area.
- Do not use naked flames, such as matches or cigarette lighters.
- Do not smoke.
- Turn off the gas supply at the gas meter.
- Open the windows and doors.
- Warn other residents.
- Get out of the house.
- Consult your gas supplier, service agent or other competent person.

Telephone the National emergency number: 0800 111 999

2.3 Safety instructions

Always observe the following safety instructions and regulations.



Danger
Inflammable mixtures of gas and air may explode. Do not use or store explosive or easily flammable substances such as petrol or paint in the same room as the appliance.



Danger
Risk of poisoning and explosion due to a malfunction. Never put the safety devices out of operation or tamper with them so as to impair their function.

2.4 Modifications in and around the boiler

No modifications may be made to the following items:

- The boiler
- The gas, water and electrical supply
- The flue system
- The safety valve for the heating water
- Any structural changes around the appliance that could affect the operational safety of the boiler.

2 Safety

**Caution**

Inappropriate modifications can cause damage. Never tamper with the boiler or other parts of the system. Never attempt to perform maintenance or repairs yourself.

- Do not damage or remove seals on components. Only authorised engineers or our customer service may remove sealed components.

**Danger****Risk of scalding.**

The water coming out of the tap can be very hot (ecoTEC combination boiler only).

**Caution****Risk of damage.**

Do not use sprays, solvents, chlorinated cleaning agents, paint, adhesives or similar substances in the vicinity of the appliance. These substances can cause corrosion, including in the flue system.

Installation and setting**Important**

The appliance must be installed and serviced by a competent person as stated in the Gas Safety (Installation and Use) Regulations 1998. In IE, the installation must be in accordance with the current edition of I.S.813 'Domestic Gas Installations', the current Building Regulations and reference should be made to the current ETCI rules for electrical installation.

**Caution**

The appliance may only be operated with its case properly and permanently closed. Otherwise, in unfavourable conditions, material damage or even injury or death can result.

Filling pressure of the heating system

Regularly check the filling pressure of the heating system (see 4.3.2).

Leaks (ecoTEC combination boiler only)

If there is a leak in the water pipes between the appliance and the taps, immediately turn off the cold water service valve and have your engineer repair the leak.

Frost protection

Your boiler is equipped with a frost protection function: If the heating water temperature drops below 5 °C when the main switch is ON, then the boiler goes into operation and heats the boiler circuit to approx. 30 °C.

**Note**

It cannot be guaranteed that water will circulate throughout the entire heating system.

If the boiler is not operated for several hours during very cold weather there is therefore the possibility of the system freezing.

Please ensure that if you are absent during a period of frost the central heating remains in operation and all rooms are kept above freezing point.

It must be remembered, however, that the boiler will be automatically switched off by the built in monitoring devices if certain faults occur, e.g. interruption in the gas or electricity supply or faults in the flue gas system. To overcome this possibility you can drain both the central heating system and boiler.

**Note**

Frost protection and monitoring devices can only function when the main switch of the unit is set to the "I" position and the boiler is connected to the electrical supply.

3 Instructions on operation

3.1 Factory guarantee

3.1.1 Two year guarantee for ecoTEC plus and three year guarantee for ecoTEC exclusive boilers

Vaillant undertakes to rectify any manufacturing defect that occurs within twenty four months (ecoTEC plus) or thirty six months (ecoTEC exclusive) of the installation date.

For the 2nd or 3rd years of the guarantee to be valid an annual service must be carried out by a CORGI registered installer commencing one year after installation.

The cost of this annual service is not included in the guarantee.

3.1.2 One year guarantee for ecoTEC pro boilers

Vaillant undertakes to rectify any manufacturing defect that occurs within twelve months of the installation date.

3.1.3 Registering with us

Registration is simple. Just complete the Guarantee Registration Card and return to Vaillant within 30 days of installation. Your details will then be automatically registered within the Vaillant scheme.

Note

No receipt will be issued.

3.1.4 Immediate help

If your Vaillant boiler develops a fault your first action should be to contact your installer, as his professional assessment is needed under the terms of our Guarantee. If you are unable to contact your installer, phone Vaillant Service Solutions: 0870 6060 777

3.2 Intended use

Vaillant ecoTEC boilers are state-of-the-art appliances which have been constructed in accordance with recognised safety regulations. Nevertheless, there is a risk of injury or death to the user or others and damage to the appliance or other property in the event of misuse or use for which the appliance is not intended.

The appliances are designed to generate heat for connected hot water central heating systems. Any other use is considered to be use other than intended. The manufacturer/supplier is not liable for any resulting damage. The user alone bears the risk.

Intended use includes the observance of the operating and installation manual and all other applicable documents, as well as adherence to the maintenance and inspection conditions.

Caution

Any incorrect use is forbidden.

3.3 Care

- Clean the exterior your appliance with a damp cloth and a little soap.

Note

Do not use scouring or cleaning agent, which might damage the housing or plastic fittings.

3.4 Recycling and disposal

Both your Vaillant ecoTEC boiler and its packaging consist mainly of recyclable raw materials.

3.4.1 The appliance

Do not dispose of your Vaillant ecoTEC boiler or any of its accessories with household waste. Make sure the old appliance and any existing accessories are disposed of properly.

3.4.2 Packaging

Please leave the disposal of the transport packaging to the expert company which installed the appliance.

Note

Please observe the applicable national legal regulations.

4 Operation

4 Operation

4.1 Overview of controls on ecoTEC plus and ecoTEC exclusive

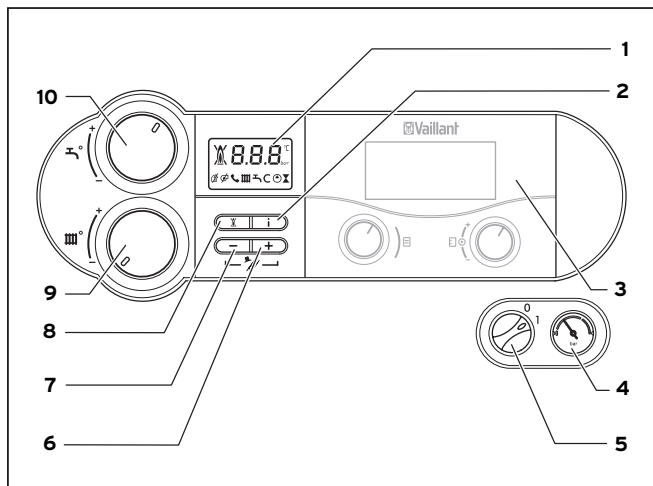

Fig. 4.1 ecoTEC plus and ecoTEC exclusive controls

For access to the controls open the front flap by pulling at the centre of the case strip.

- 1 Display indicating the current heating flow temperature, the pressure in the heating system, the operating mode or additional information
- 2 The "i" information button
- 3 Built in control/timer (if fitted)
- 4 Pressure gauge displaying the pressure in the heating system
- 5 Main ON/OFF control
- 6 "+" button for moving forward in the display
- 7 "-" button for moving back in the display or for displaying the pressure in the heating system
- 8 "Reset" button
- 9 Maximum radiator temperature control
- 10 Maximum hot water temperature control and warmstart ON/OFF control (ecoTEC plus combination boilers only)

Advanced multifunctional display system

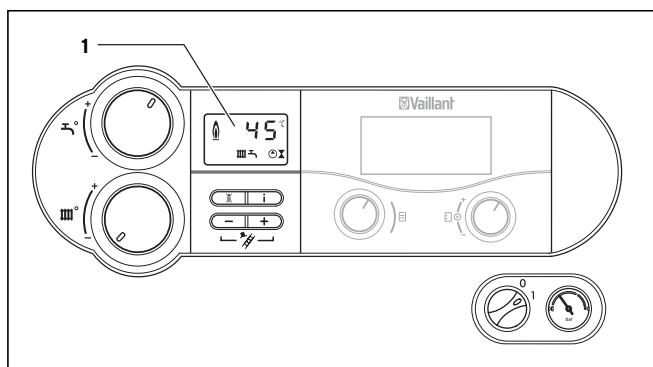

Fig. 4.2 Display on ecoTEC plus and ecoTEC exclusive

The ecoTEC plus and ecoTEC exclusive appliance is fitted with a digital information and analysis system. This system provides information on the operating status of your appliance. During normal operation, the display (1)

shows the current heating flow temperature (in this example 45 °C). In the event of a fault, an error code appears instead of the temperature. The ecoTEC exclusive display has also cleartext for a direct information. The display also gives the following information:

1 Indication of the current heating system flow temperature or water pressure in the heating system or display of a status or error code

Actual setting of the modulation (only ecoTEC exclusive)

Abcd... Clear text display (only ecoTEC exclusive)
Abcd...

Fan speed malfunction

Fan speed malfunction

As long as this symbol appears in the display, a heating flow temperature and hot water outlet temperature is set by the vrnetDIALOG accessory, which means the appliance uses temperatures other than those set using the controls (9) and (10).

This condition can only be ended:
- using vrnetDIALOG or
- by a change in temperature at controllers (9) or (10) of more than ±5 K.

This condition cannot be ended:
- with the "Reset" button (8) or
- by turning the appliance off or on.

Heating mode active
Illuminated: Heating mode
Flashing: Anti cycling mode active



Hot water supply active (ecoTEC plus combination boilers only)
Illuminated: Hot water demand

(ecoTEC system boilers only)
Illuminated: Heating of an indirect hot water cylinder turned on
Flashing: Heating demand from the hot water cylinder, burner on

Warmstart system active (ecoTEC plus combination boilers only)
Illuminated: Warmstart turned on
Flashing: Warmstart demand, burner on

Internal pump is running

Gas valve is activated

-  Flame with cross:
Boiler is at lock out and will display fault code
-  Flame without cross:
Normal burner operation

4.2 Overview of controls on ecoTEC pro

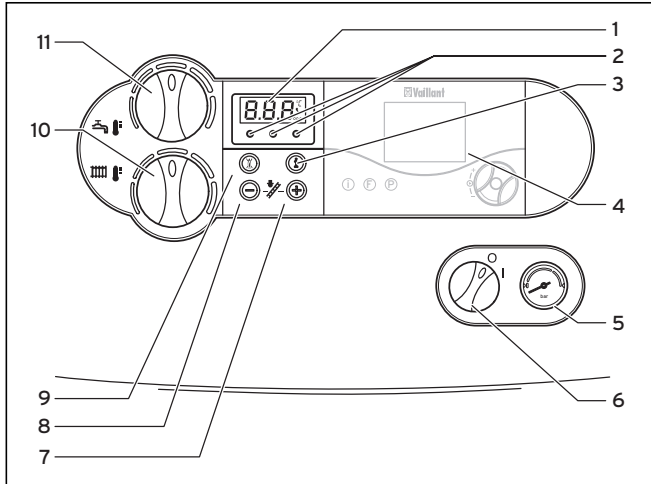



Fig. 4.3 ecoTEC pro controls

- 1 Display indicating the current heating flow temperature, the pressure in the heating system or additional information
- 2 Indicator lights to display the current operating mode
- 3 The "i" information button
- 4 Built in control/timer (if fitted)
- 5 Pressure gauge displaying the pressure in the heating system
- 6 Main ON/OFF control
- 7 "+" button for moving forward in the display
- 8 "-" button for moving back in the display or for displaying the pressure in the heating system
- 9 "Reset" button
- 10 Maximum radiator temperature control
- 11 Maximum hot water temperature control and warmstart ON/OFF

Multifunctional display system

ecoTEC pro boiler has a multifunction display (1). When the main ON/OFF control is in the "ON" position the display will normally show the system CH flow temperature of water in the boiler circuit (45 °C in the example), which confirms that the boiler is functioning correctly.

-  As long as this symbol appears in the display, a heating flow temperature and hot water outlet temperature is set by the vrnetDIALOG accessory, which means the appliance uses temperatures other than those set using the controls (10) and (11). This condition can only be ended:
 - using vrnetDIALOG or
 - by a change in temperature at controllers (10) or (11) of more than ±5K.

- This condition cannot be ended:
- with the "Reset" button (9) or
 - by turning the appliance off or on.

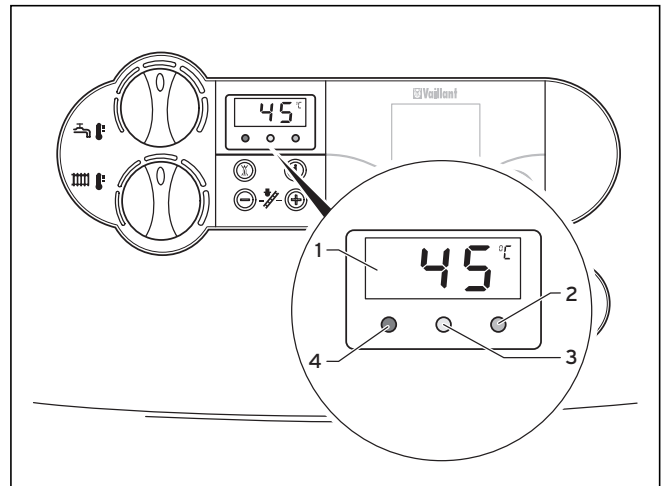



Fig. 4.4 ecoTEC pro indicator lights

- 1 Display indicating flow temperature or the system pressure or the relevant fault code.
- 2 Green warmstart indicator
Illuminated = Warmstart switched ON
Not illuminated = Warmstart is switched OFF and there is no demand for hot water
Flashing = There is either a demand for hot water or warmstart
- 3 Yellow indicator - Illuminated = Main burner ignited
- 4 Red indicator
Illuminated = Boiler is at lock out and will display fault code

4.3 Initial checks before turning on

4.3.1 Opening the service valves

ecoTEC plus and pro

 **Note**
If a bottom cover is fitted to the boiler the service valves are behind this cover.

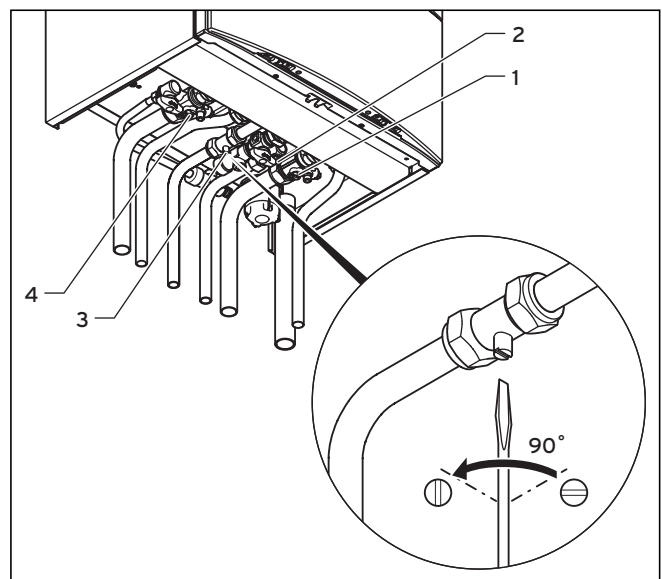

Fig. 4.5 Opening the service valves on ecoTEC plus combination boilers

4 Operation

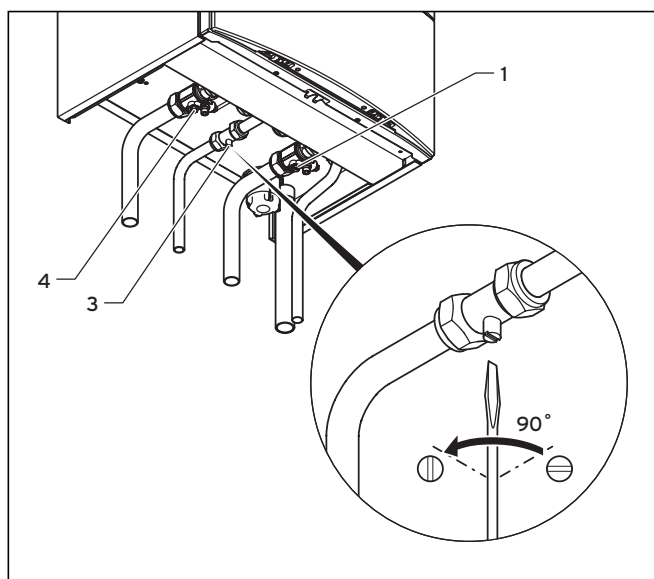

Fig. 4.6.1 Opening the service valves on ecoTEC system boilers

- Ensure that the service valves in the heating flow and return (4 and 1) and the gas service valve (3) are open. The flow, return and gas service valves are open when the screwdriver slot is in the same direction as the pipework.
- On ecoTEC combination boilers only: Ensure the cold water service valve (2) is open. This can be checked by opening a hot water tap and ensuring water flows.



Caution

The pressure relief valve is provided for safety reasons and must not be interfered with.

ecoTEC exclusive

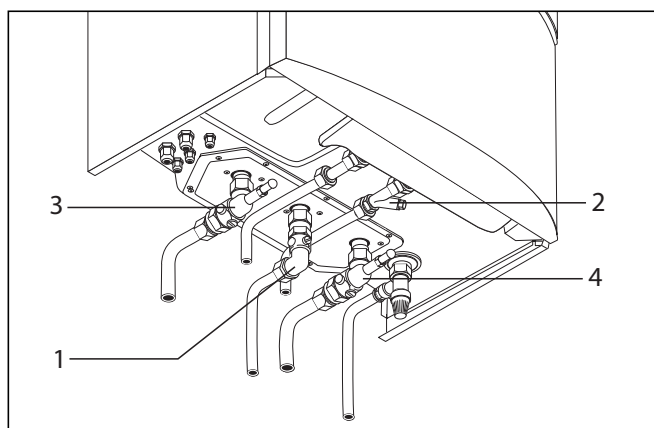

Fig. 4.6.2 Opening the service valves on ecoTEC exclusive

- Ensure the cold water service valve (2) is open. This can be checked by opening a hot water tap and ensuring water flows.
- Ensure that the service valves in the heating flow and return (4 and 3) and the gas service valve (1) are open.

The flow, return and gas service valves are open when the line marking has the same direction as the pipe.



Attention

The pressure relief valve is provided for safety reasons and must not be interfered with.



Note

A bottom cover is fitted to the appliance. The service valves are fitted behind this cover.

4.3.2 Checking the system pressure

- Check the water pressure of the system using the pressure gauge (1) before putting the boiler into operation. For the heating system to operate properly, the indicator on the pressure gauge must be in the dark grey zone when the system is cold. This is a filling pressure between 1.0 and 2.0 bar. If the indicator is in the light grey area (below 0.8 bar), fill the system up with water before putting the boiler into operation.

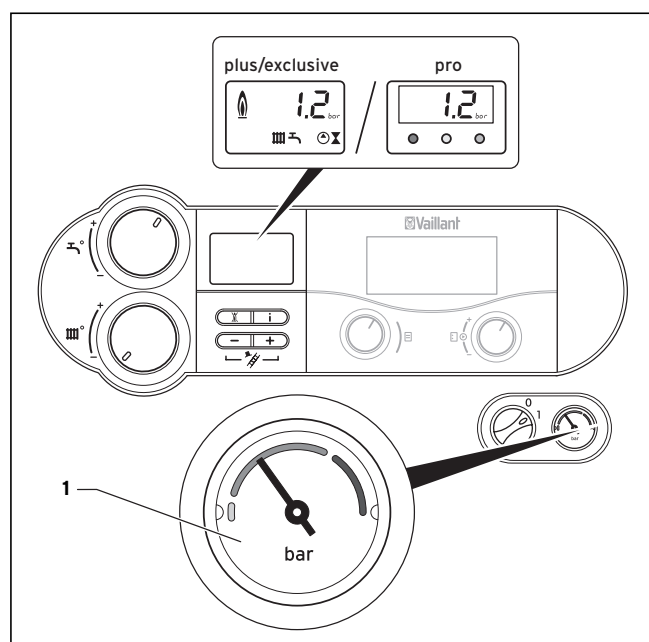

Fig. 4.7 Checking the filling pressure of the heating system



Note

The ecoTEC boiler has a pressure gauge and a digital pressure display. The pressure gauge allows you to quickly check whether the filling pressure is in the correct range, even when the appliance is switched off. When the appliance is in operation, you can see the exact pressure in the display. Activate the pressure display by pressing the “-” button (2). After 5 seconds the display returns to the flow temperature.



Note

Your appliance has a pressure sensor. If the pressure falls below 0.6 bar the pressure flashes in the display. If it falls below 0.3 bar the appliance switches off. The error message F.22 appears in the display. The system must be filled with water before you start up the appliance again.

4.4 Turning the boiler ON

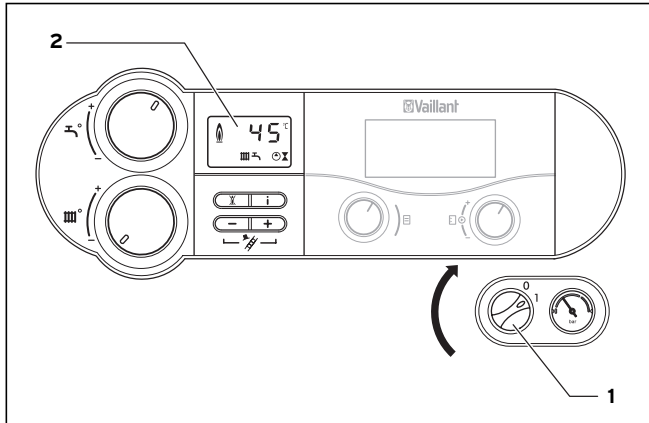

Fig. 4.8 Switching on the appliance (example: ecoTEC plus)

- Use the main ON/OFF control to switch the appliance on.
I: "ON" - 0: "OFF"

When you switch on the appliance, the current operating status appears in the display (2). To adjust the appliance according to your requirements, read sections 4.5 and 4.6, which describe the setting options for hot water supply and heating.



Caution

Risk of damage.

The boiler frost protection and monitoring systems are only active when the main ON/OFF control of the appliance is in the "I" position and it is not disconnected from the main power supply.

4.5 Domestic hot water with ecoTEC combination boilers

The boiler must only be used when the heating system contains water (see 4.3.2).

4.5.1 Setting the water temperature

- Switch on the appliance as described in section 4.4.
- The domestic hot water temperature can be adjusted using the hot water temperature control (3).
- Turn the control clockwise to increase the temperature and anti-clockwise to decrease the temperature. This corresponds to:
 - left limit approx. 35 °C
 - right limit max. 65 °C.

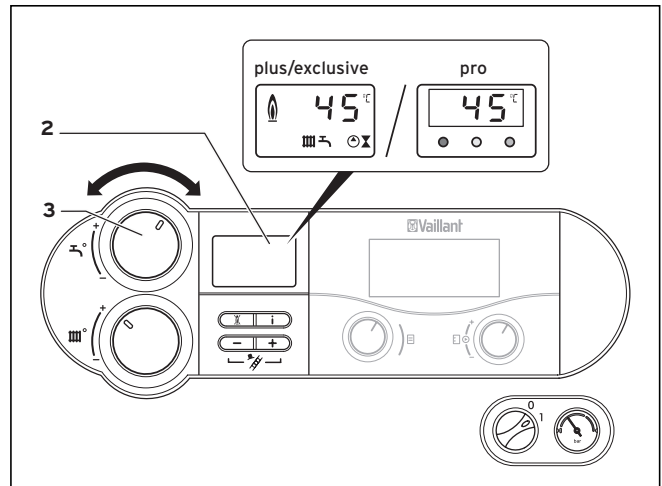

Fig. 4.9 Setting the water temperature



Note

This control adjusts the maximum domestic hot water temperature. If adjusting the control upwards appears to have no effect on the temperature, then the boiler is already operating at full output for the selected flow rate.

When you adjust the required temperature, the set value is shown in the display (2). After five seconds the display returns to standard mode (the current heating flow temperature).



Caution

If you live in a hard water area please do not set the control knob (3) above the mid (12 o'clock) position to prevent excessive scale formation.

4.5.2 Switching the warmstart function on and off

The warmstart system of the ecoTEC combination boilers provides you with hot water at the required temperature immediately. To do this, the hot water heat exchanger of the ecoTEC is kept at a pre-selected temperature level and the boiler will therefore periodically operate to maintain this temperature.

ecoTEC plus and ecoTEC exclusive

- Activate the warmstart system by briefly turning the knob (1) all the way clockwise (position a).

Then select the desired hot water outlet temperature again, e.g. setting b (refer to Section 4.5.1). The appliance automatically adapts the hot holding temperature to the set hot water temperature. The tempered water is directly available at the taps; the symbol **C** flashes in the display.

- Switch off the warmstart system by briefly turning the knob (1) all the way anti-clockwise (position c). The symbol **C** disappears. Then select the required hot water outlet temperature again, e.g. setting b.

4 Operation

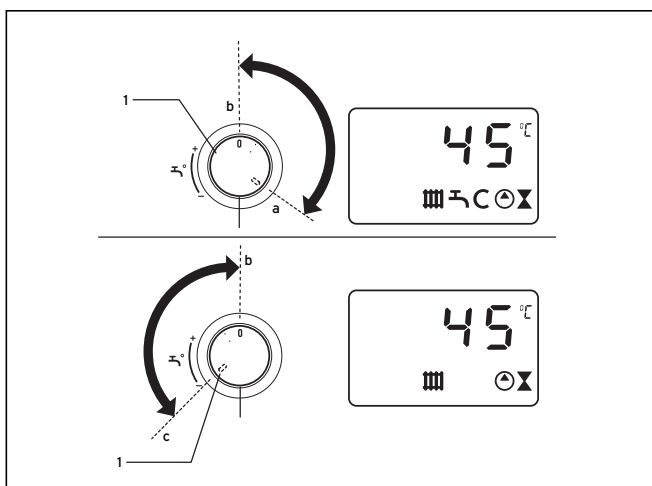

Fig. 4.10 Switching the warmstart system on and off with ecoTEC plus and ecoTEC exclusive

ecoTEC pro

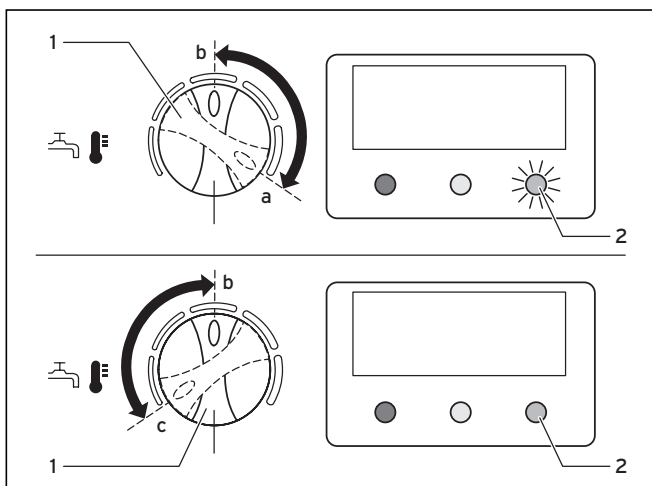

Fig. 4.11 Switching the warmstart system on and off with ecoTEC pro

- Activate the warmstart system by briefly turning the knob (1) all the way clockwise (position a). The green LED (2) lights up. Then select the required temperature, e.g. setting b, see 4.5.1.

The water is kept at a constant temperature of 55 °C and is available immediately as you turn on a tap.

- Switch off the warmstart system by briefly turning the knob (1) all the way anti-clockwise (position c). The green LED (2) goes out. Then select the required hot water outlet temperature again, e.g. setting b.

4.5.3 Drawing hot water (ecoTEC combination boilers only)

On opening a hot water tap (1) at a supply point (basin, shower, bath, etc) the ecoTEC combination boiler will automatically operate to deliver hot water. On closing the tap the boiler switches OFF (or continues to operate for central heating if required).

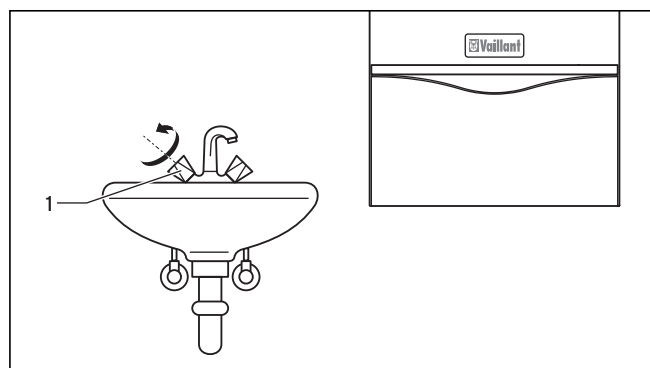

Fig. 4.12 Drawing off hot water (example: ecoTEC plus)

4.6 Heating operation

The boiler must only be used when the heating system contains water (see 4.3.2).

4.6.1 Setting the maximum radiator temperature control

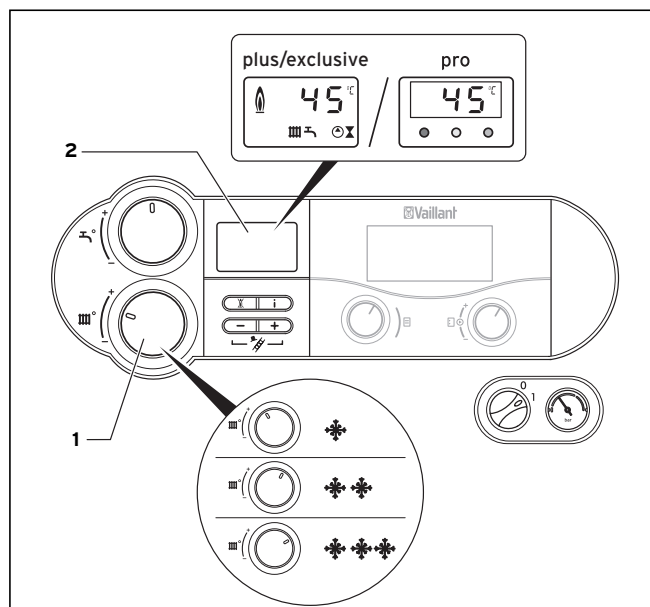

Fig. 4.13 Setting the maximum radiator temperature control

Set the maximum radiator temperature control to the desired setting using the control knob (1).

We recommend the following settings:

- Left setting during spring and autumn,
- Middle setting during mild winter,
- Right setting during cold winter.

When you adjust the temperature, the set value is shown in the display (2). After five seconds the display returns to standard mode (the current heating flow temperature). Normally you can adjust the knob (1) continuously up to a flow temperature of 75 °C. However, higher temperatures can be set on your appliance, have your engineer make adjustments so that you can operate the heating system at higher flow temperatures.

4.6.2 Switching off heating (summer operation)

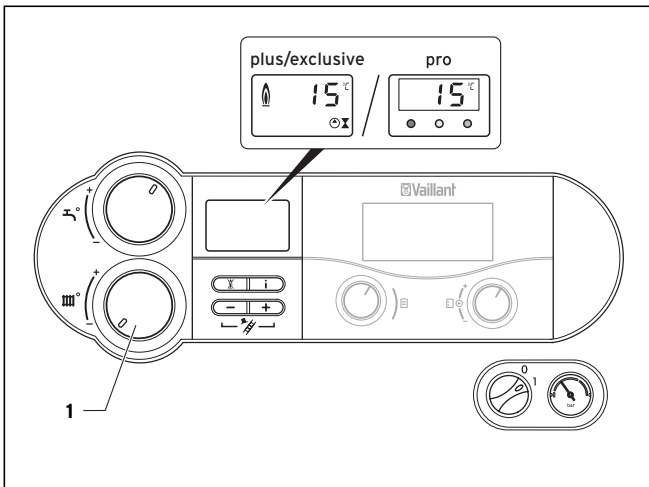

Fig. 4.14 Switching off heating (summer operation)

You can switch off the heating in summer without switching off the hot water supply.

- Turn the knob (1) for setting the maximum radiator temperature all the way to the left.

4.6.3 Setting a room- or outside temperature controller

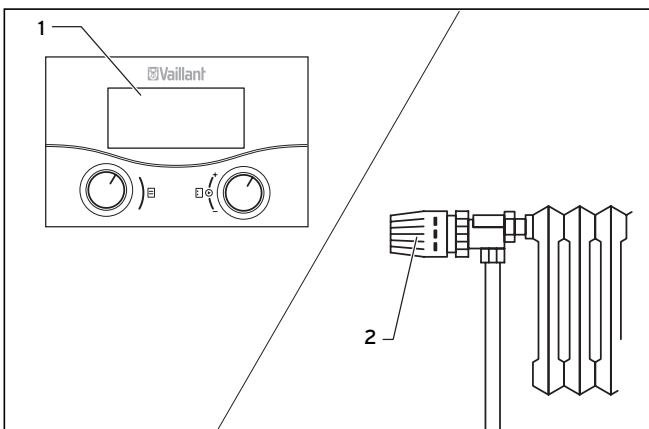

Fig. 4.15 Setting a room- or outside temperature controller

- Set the room thermostat (1) and/or the thermostatic radiator valves (2) according to the instructions supplied with the control(s).

Note
Vaillant offer room thermostat/time control accessories which give accurate and economic room temperature control as well as improved comfort.

The boiler will now operate automatically to provide central heating for the conditions selected on the external controls (ecoTEC combination boilers will also provide domestic hot water on demand). After the boiler stops operating the pump will continue to operate for a short period to fully disperse the heat from the boiler.

Note
The boiler incorporates an anti-cycling economiser control to prevent energy wasteful ON and OFF operation of the boiler for short periods when in the central heating mode. When turning the room thermostat to a higher setting there may therefore be a short delay before the boiler operates.

4.7 Status displays

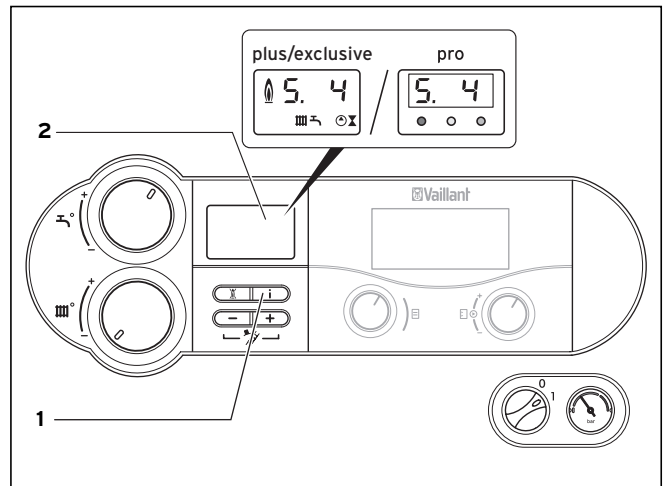

Fig. 4.16 Status displays

Display	Meaning
Displays during heating operation	
S. 0	No heat required
S. 1	Pump running
S. 3	Ignition sequence (heating operation)
S. 4	Burner ignited
S. 6	Fan and pump overrun
S. 7	Pump overrun
S. 8	Anti-cycling mode (after heating operation)
S.30	Room thermostat 3/4 no heating demand
S.31	Summer mode active
S.34	Frost protection mode
Displays in hot water operation (ecoTEC combination boilers only)	
S.10	Hot water demand
S.14	Burner ignited
Displays for hot holding operation (ecoTEC combination boilers only)	
S.20	Hot holding request
S.24	Hot burner holding operation on
Displays in cylinder charging mode (ecoTEC system boilers only)	
S.20	Cylinder charging request
S.24	Cylinder charging burner on

Table 4.1 Status codes (selection, a complete set of status codes can be found in the installation and servicing manual)

4 Operation

The status displays provide information on the operating status of the appliance.

- Press the "i" button (1) to activate the status displays.

The display (2) then shows the current status code, for example "S. 4" for burner operation. The table below explains the most important status codes.

In switching phases, for example on starting up again after the flame was extinguished, the status message "S." briefly appears.

- Press the "i" button (1) again to switch the display back to normal mode.

Note

The ecoTEC exclusive display has also cleartext for a direct information

4.8 Troubleshooting

In the unlikely event that a problem occurs with the operation of the ecoTEC boiler, the following points should be checked:

Boiler fails to operate:

- Is the gas supply turned on (see 4.3.1)?
- Is the water supply turned on (ecoTEC combination boilers only, see 4.3.1)?
- Is there enough water in the heating system (see 4.3.2)?
- Is the electrical supply switched ON?
- Is the main ON/OFF control in the "ON" position (switch position "I", see 4.4)?
- Is there an ignition problem (see 4.8.2)?

Hot water operates but no central heating (ecoTEC combination boilers only)

- Is the heating turned ON (see 4.6.1)?
- Are all external heating controls ON (see 4.6.3)?

Caution

Inappropriate modifications can cause damage. If your boiler still does not operate then please consult your installer or Vaillant Service Solutions (0870 6060 777).

4.8.1 Problems due to low system water pressure

The device switches to "Fault" if the water pressure in the heating system is too low. This malfunction is indicated by the fault code "F.22" (dry fire) or "F.23" or "F.24" (lack of water).

You can only start up the appliance again when the heating system is sufficiently filled with water.

4.8.2 Ignition problems

If the burner fails to ignite after five attempts, the device does not start up and switches to "Fault". This is indicated by the fault code "F.28" or "F.29" in the display. On ecoTEC plus appliances the display also shows the flame symbol with a cross through it (1). On ecoTEC pro appliances, the red LED (2) also lights up.

Automatic ignition can only take place after you manually reset the fault.

- To reset the fault, press the reset button (3) and hold it down for one second.

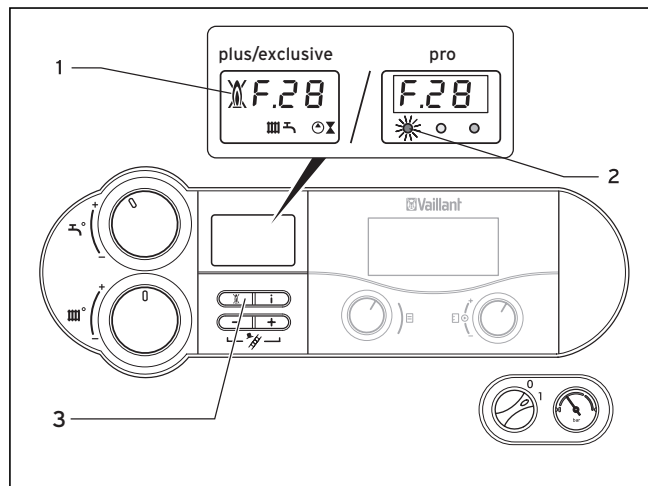

Fig. 4.17 Troubleshooting



Caution

If the boiler still shuts off after three attempts of resetting, please consult your installer or Vaillant Service Solutions.

4.8.3 Flue problems

The appliances are fitted with a fan. If the fan does not work properly, the appliance will switch itself off.

The display shows the symbols X and O and the fault message "F.32".



Note

If contacting Vaillant Service Solutions please remember to quote the fault code, as this will help to pinpoint the fault.

4.9 Turning off the boiler

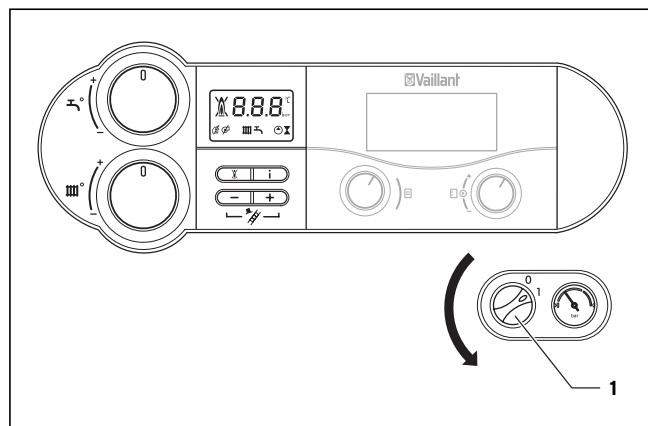

Fig. 4.18 Switching off the appliance

- Turn the main ON/OFF control (1) to the „0“ position.

**Caution**

The boiler frost protection and monitoring systems are only active when the main ON/OFF control of the appliance is in the "I" position and it is not disconnected from the main power supply.

To ensure that these protection devices remain active, switch your boiler on and off using the external controller.

**Note**

If the appliance is switched off for a long time (for example when you are on holiday) you should also turn off the gas supply, the cold water service valve and the electrical supply.

**Note**

Do not turn the ecoTEC system boilers OFF if a hot water cylinder is also incorporated in the system unless there is no demand for domestic hot water.

4.10 Frost protection

The frost protection feature only protects the boiler. Any other parts of the system liable to frost damage should be protected accordingly.

**Caution**

The frost protection and monitoring systems are only active when the main ON/OFF control of the appliance is in the "I" position and it is not disconnected from the main power supply.

Frost protection function

The boiler has a frost protection function. If the heating flow temperature falls below 5 °C with the main ON/OFF control turned on, the appliance starts up and heats the boiler to 30 °C.

**Caution**

Parts of the system may freeze. The frost protection function cannot guarantee that water flows through the entire heating system.

4.11 Maintenance and customer service**Inspection and maintenance**

Permanent operational readiness, reliability and a long service life require inspections and maintenance work to be regularly carried out by a heating engineer or Vaillant. For further details please contact Vaillant Service Solutions: (0870 6060777).

**Danger**

Risk of injury and damage due to improper handling.

Never attempt to perform maintenance or repairs on the appliance yourself. Have a specialist heating company do the work. We recommend signing a service agreement. The reliability of the appliance can be impaired, resulting in damage to property or personal injury if maintenance work is not carried out.

Regular servicing ensures maximum efficiency and economical operation of your gas boiler.

Diagram for ecoTEC pro showing four installation scenarios. Each scenario includes a weather icon (sun, rain, snow, or a combination), a temperature gauge, and a radiator icon. The radiator icons show different valve configurations: 1) fully open (no symbols), 2) partially open (one valve symbol), 3) fully open (two valve symbols), and 4) fully open with a bypass (two valve symbols and a bypass symbol). A control panel icon labeled 'VRT/VRC' is shown at the bottom right.

Diagram for ecoTEC plus / exclusive showing four installation scenarios. Each scenario includes a weather icon, a temperature gauge, and a radiator icon. The radiator icons show different valve configurations: 1) fully open (no symbols), 2) partially open (one valve symbol), 3) fully open (two valve symbols), and 4) fully open with a bypass (two valve symbols and a bypass symbol). A control panel icon labeled 'VRT/VRC' is shown at the bottom right.

Diagram for ecoTEC pro showing the connection of the radiator to the boiler. The boiler is labeled 'F...' and has various symbols. The radiator is shown with two valves. A pressure gauge icon is also present. The diagram is labeled 'ecoTEC pro'.

Diagram for ecoTEC plus / exclusive showing the connection of the radiator to the boiler. The boiler is labeled 'F...' and has various symbols. The radiator is shown with two valves. A pressure gauge icon is also present. The diagram is labeled 'ecoTEC plus / exclusive'.



Vaillant Ltd

Vaillant House ■ Medway City Estate ■ Trident Close ■ Rochester ■ Kent ME2 4EZ
Telephone 01634 292300 ■ Fax 01634 290166 ■ www.vaillant.co.uk ■ info@vaillant.co.uk