

INSTALLATION & SERVICE INSTRUCTIONS

MITRE - AS

GAS FIRED INSTANTANEOUS SINK WATER HEATER

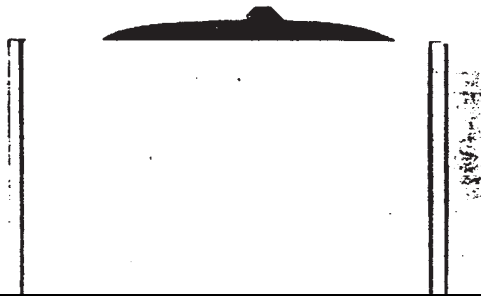

THIS DOCUMENT HAS BEEN PROVIDED BY



PLEASE VISIT WWW.HEATINGSPPARES247.COM FOR FURTHER INFORMATION AND GENUINE PARTS & SPARES AT LOW PRICES

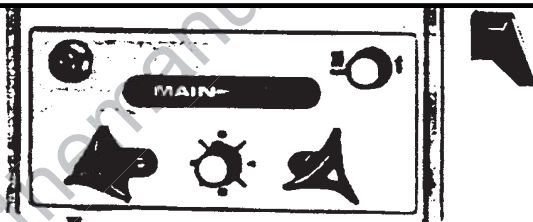

G. C. APPLIANCE No. 51 476 33

THE GAS SAFETY (INSTALLATION AND USE) REGULATIONS 1984

In your own interest, and that of safety, it is the law that all gas appliances are installed by competent persons, in accordance with the above regulations. Failure to install appliances correctly could lead to prosecution.

Follow these instructions carefully and comply with conditions set out in the current edition of the Building Regulations Local Water Authority Regulations and relevant Codes of Practice relating to installation of Domestic Water Heating Appliances. (CP. 342 and BS. 5546).

LEAVE THESE INSTRUCTIONS BY THE METER



A minimum clearance of 450mm (18in.) must be observed between the top of the appliance and the ceiling when installed.

The room in which the appliance is fitted must be of greater volume than 6m³ (215ft³). In addition rooms between 6 - 11m³ (215—390ft³) must be provided with an air vent to the outside atmosphere having minimum effective area of 35cm² (5in²) in addition to an openable window.

For room greater than 11m³ (390ft³) an air vent is not required but the room must still contain an openable window.

IMPORTANT

The heater is supplied ready for connecting the gas supply from the left hand side. If connection of the gas supply from the right hand side is preferred the gas tap should be re-positioned before fixing. See gas connection section page 4.

FIXING THE HEATER

Pull handles and knobs from front of appliance. Remove the two fixing screws 1. Fig. 1.

Carefully swing out bottom edge of case front to clear tap spindles. Disconnect wire lead from rear of spark igniter and lift off case front. Determine the correct position for the heater taking into account instructions given under "VENTILATION AND AIR SUPPLY".

Place appliance in position on the wall and mark the wall for top fixing point.

Drill hole in wall using an 8mm drill and insert plastic plug. Screw stud into plug down to the depth of the threads. Remove any burrs from screw. Place appliance on the wall ensuring that the stud engages into the fixing hole in rear of appliance. Using a spirit level ensure that the appliance is vertical temporarily tighten the grub screw at the top rear of the appliance case. Hold clips in position towards outside edge of slots as shown in Fig. 2 and mark wall. Slacken grub screw and lift off appliance. Drill and plug wall to take clip securing screws. Place appliance into position on wall, tighten grub screw and secure at bottom using the fixing clips.

WATER INLET CONNECTION

It is strongly recommended that the use of loose jumper washer type cocks be avoided.

Flush out all foreign matter from the supply pipe before connecting to the appliance.

Connect copper tail and sealing washer to water service cock 2. Fig. 3 and connect water supply using 15mm copper pipe to B.S. 2871.

IMPORTANT: Remove the sealing washer from copper tail before making any soldered joints to prevent damage from heat. Replace washer on completion.

WATER OUTLET SHORT SPOUT (WHERE APPLICABLE)

Connect short spout and sealing washer 4. Fig. 3 to water outlet 3 Fig. 3.

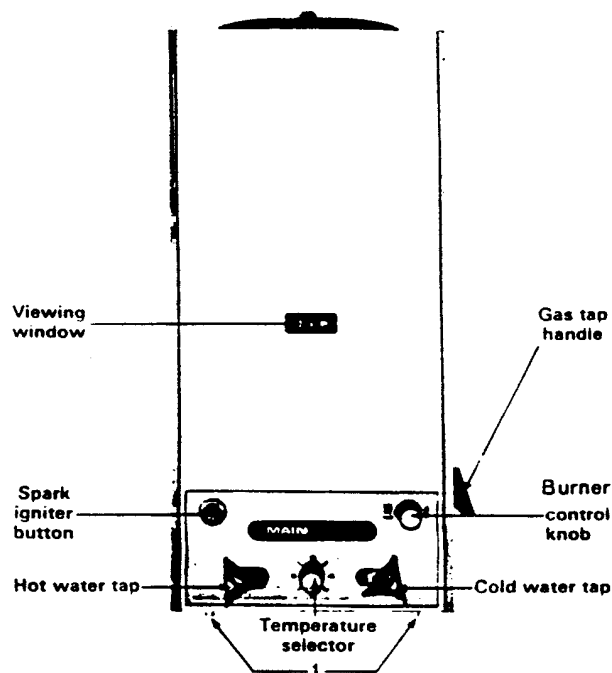

Fig. 1.

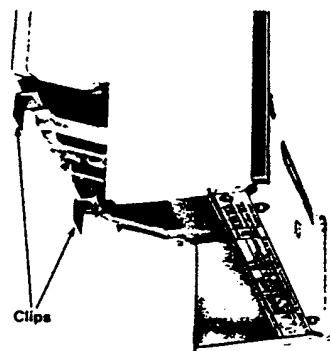





Fig. 2.

Turn the burner control knob to the spark position marked .
Repeatedly press and release the spark igniter button marked  until the pilot is lit.
The pilot flame can be observed through the viewing window.
Once the pilot is lit wait 10 seconds and turn the burner control knob to the working position marked .
If the pilot goes out wait one minute and repeat the above operations.
Turn on the hot tap and check ignition of main burners.

CHECKING BURNER PRESSURE

Allow burners to operate for one minute before checking the pressures shown below.

GAS GROUP	GAS INLET PRESSURE		NOMINAL BURNER PRESSURE		INJECTOR SIZE
	mbar	in. w.g.	mbar	in. w.g.	mm dia
N.G.	20	8	5.7	2.3	1.25

After checking turn off hot water tap. Remove pressure test gauge and replace screw and sealing washer.

IMPORTANT:

Remove the protective vinyl film from the namebadge. Draw the attention of the user to the warning label on the outer case. Hand the users instructions to the consumer.

Explain fully how to operate the appliance.

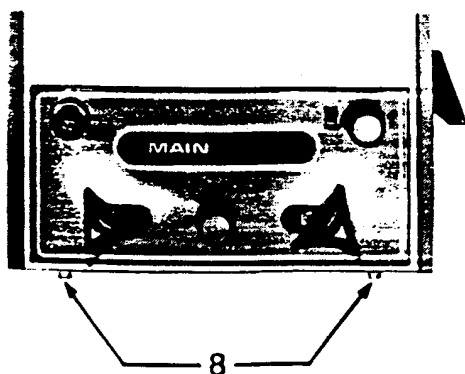

Fig.4

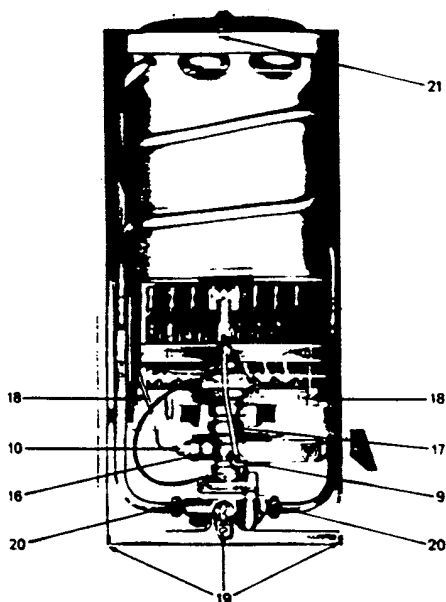

Fig.5.

1. TO REMOVE CASE FRONT

Pull handles and knobs from spindles at front of appliance. Remove two fixing screws 8. Fig. 4.

Carefully pull out bottom edge of case front to clear tap spindles.

Disconnect wire lead (push fit) from rear of spark igniter.

Lift case front and remove.

Re-assemble in reverse order ensuring that the red marked knob is fitted to the left hand front spindle and the blue marked knob is fitted to the right hand front spindle.

2. TO REMOVE SPARK IGNITER

Remove case front, see Section 1.

Pull retaining clip and washer from around the spark igniter behind case front.

Pull spark igniter forwards through case front. Re-assemble in reverse order using a new "Push Fix" retaining clip (Part Number 30265).

3. TO REMOVE THE SPARK ELECTRODE, PILOT, THERMOCOUPLE, HEAT SENSOR, PILOT REGULATOR AND ATMOSPHERE SENSING DEVICE.

IMPORTANT: Care must be taken when handling this assembly. The bi-metal strip **MUST NOT** be touched by hand, skin contact may affect the operation of the control.

IMPORTANT: The bi-metal sensor and its valve flap **MUST NOT** be mechanically opened or adjusted in any way.

Turn off the gas. Remove the case front see section 1.

Release pilot supply fixing screw 9. Fig. 5. do not remove the screw from the pilot assembly, do not lose the sealing washer. Release the thermocouple nut 10. Fig. 5. Release the 'Heat Sensor' from the heating unit (centre screw).

Pull assembly carefully forward at the bottom and remove from the appliance by gently pulling downwards to clear the burners.

Release screw 11. Fig. 6. and separate the unit.

The spark electrode and the thermocouple will now be free.

To clean the pilot jet, release union nut 12. Fig. 6. and separate unit. **DO NOT** lose the sealing washer. **DO NOT** breakdown the assembly beyond this point.

Clean by blowing through in the opposite direction to the gas flow. **DO NOT** clean by brushing or poking through the orifice.

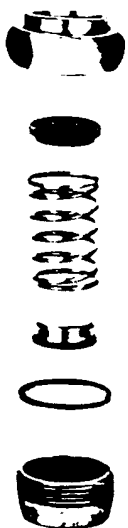

Fig. 8.

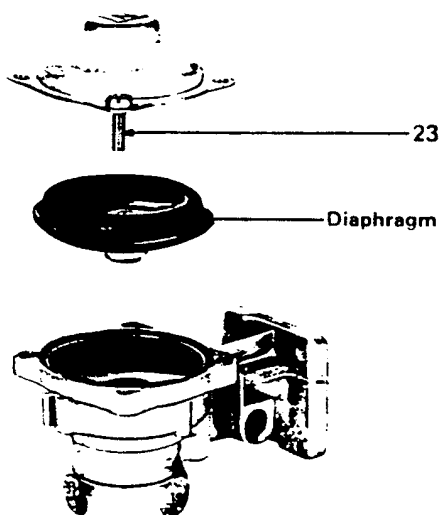
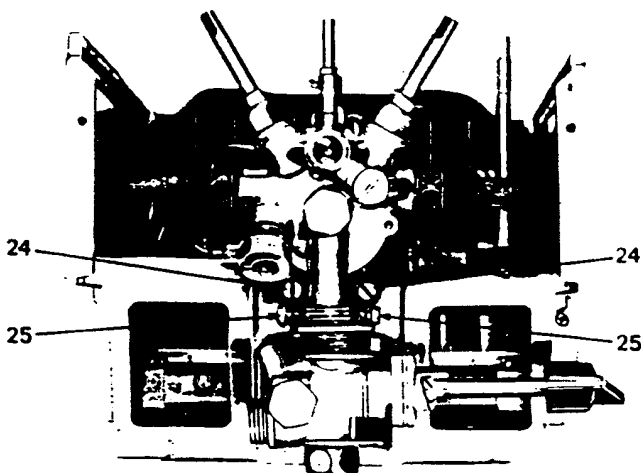

Fig. 9.



VIEW FROM UNDERSIDE

Fig. 10.

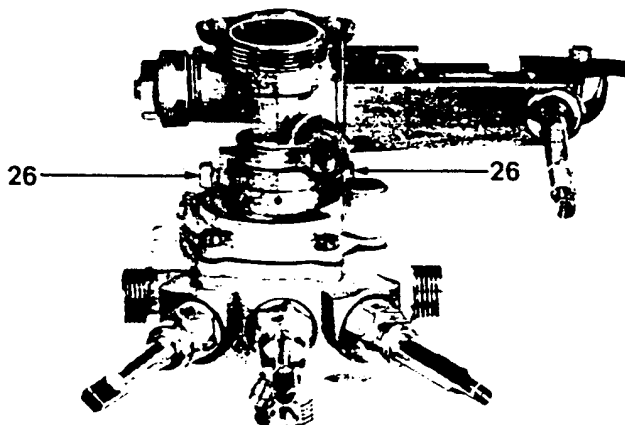

Fig. 11.

5. TO REMOVE ELECTRO-MAG. UNIT

Remove case front see section 1. Release thermocouple nut 10. Fig. 5. Release securing nut 16. Fig. 5. and pull electro-mag. unit clear of assembly. Replace in reverse order.

6. TO REMOVE BURNER ASSEMBLY AND INJECTORS

Turn off gas and water supply. Open a hot outlet to release pressure. Remove case front, see section 1. Remove the complete pilot and sensing device assembly see section 3. Release union nut 17. Fig. 5. Lift burner assembly vertically to fully expose spring and sealing washer. Remove washer and spring assembly. Remove burner assembly.

Remove two fixing screws 18. Fig. 5. and pull burner assembly off manifold. To clean injectors remove from manifold and blow through in opposite direction to gas flow. Do not clean by brushing or poking through orifice.

When re-fitting injectors re-seal the threads using an approved sealing compound, do not allow sealing compound to block the injectors. When re-assembling the main valve spring and washer ensure that the blind hole in the brass valve is correctly located on the push rod before re-fitting the burner assembly.

Re-assemble the burner unit in reverse order ensuring that the location peg at the rear of the unit engages in the positioning hole in the rear panel.

7. TO REMOVE SLOW IGNITION DIAPHRAGM

Remove burner assembly see section 6.

Remove four screws 23. Fig.9. and lift off the cover.

Lift out diaphragm assembly, replace if necessary.

Re-assemble in reverse order ensuring that the brass weight is on the under side of the diaphragm and locates in the gas chamber.

8. TO REMOVE WATER DIAPHRAGM

Turn off gas and water supply and drain unit by releasing drain screw and sealing washer 14. Fig. 7.

Remove case front see section 1.

Disconnect water supply at rear of water diaphragm assembly.

Remove front retaining plate by releasing three fixing screws 19. Fig. 5. and easing free.

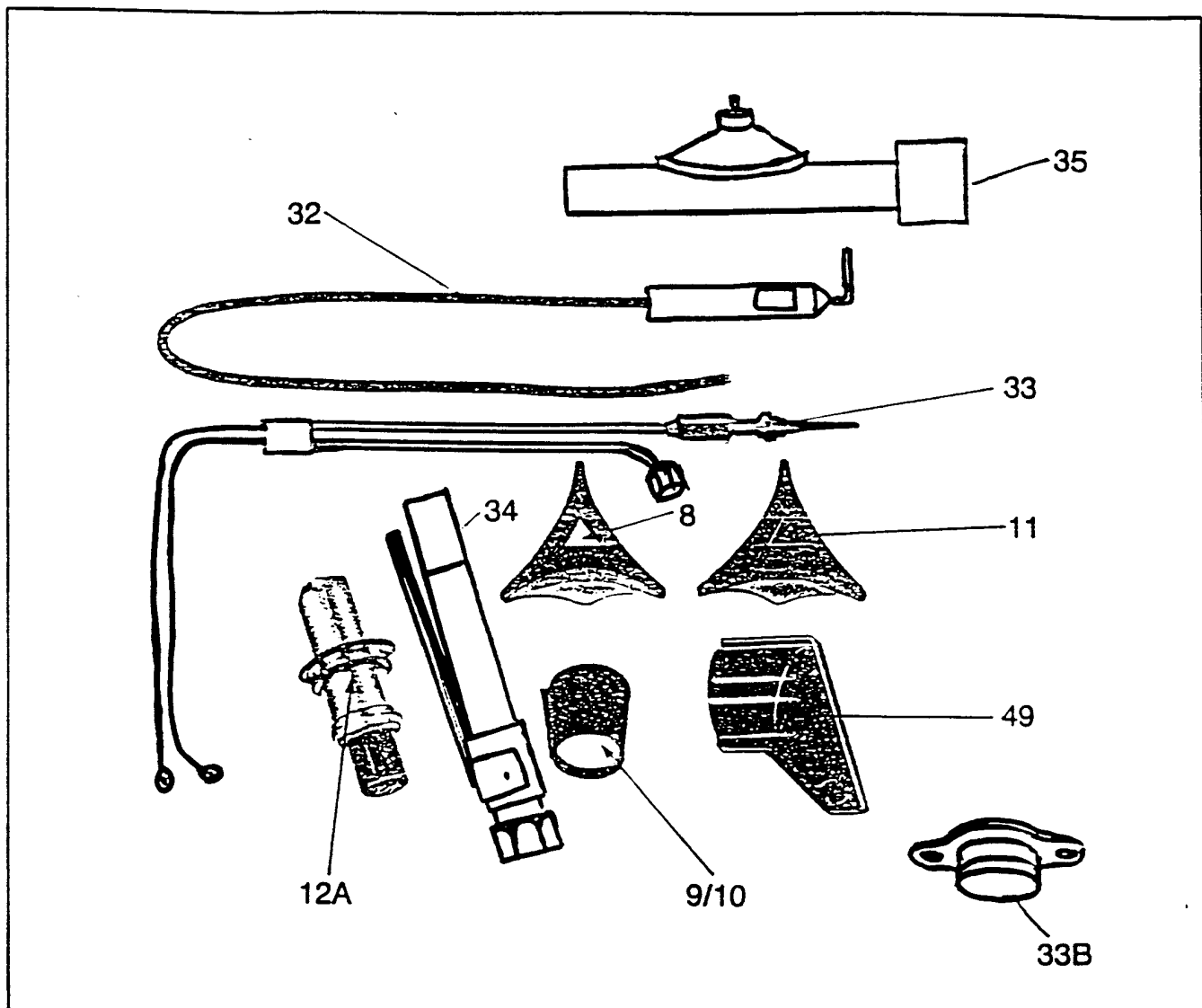

SHORT SPARE PARTS LIST

Key No.	G.C. Part No.	Description	No. Off	Makers Part No.
35	257694	Pilot regulator assembly	1	27691
32	257621	Spark Electrode	1	22189
33	—	Thermocouple	1	27783
12A	340453	Spark Igniter Assembly (Cosic P 1862-79)	1	30260
33B	—	Heat Sensor	1	27581
34	257622	Pilot burner/injector Assembly.	1	27747
8	285594	Hot Water Knob	1	31206
11	285597	Cold Water Knob	1	31207
9/10	285595	Temperature Selector/Burner Control Knob	2	22527
49	285622	Gas Tap Handle	1	20858