

# Kane 400

## Compact Combustion Analyser



**Kane International Limited**  
Kane House, Swallowfield  
Welwyn Garden City  
Hertfordshire  
AL7 1JG

Tel: 01707 375550  
Fax: 01707 393277

Stock No: 17690-6 June 2004

© Kane International Limited

THIS DOCUMENT HAS BEEN PROVIDED BY



PLEASE VISIT [WWW.HEATINGSPPARES247.COM](http://WWW.HEATINGSPPARES247.COM) FOR FURTHER INFORMATION AND GENUINE PARTS & SPARES AT LOW PRICES



*The code of practice for the installation, commissioning & servicing of gas fires and wall heaters*

# CONTENTS

**Page No:**

1. ANALYSER LAYOUT AND FEATURES .....	1
1.1 Instrument Features And Keypad .....	1
1.2 Standard Probe Configuration .....	2
1.3 Analyser Connections .....	3
2. SAFETY WARNING.....	4
3. FIRST TIME USE.....	4
3.1 Installing Batteries .....	4
4. NORMAL START UP SEQUENCE.....	5
4.1 Every Time You Use The Analyser.....	5
4.2 Automatic Calibration.....	6
4.2.1 Quick Autozero .....	6
4.2.2 Pressure and Temperature Mode (PTM) .....	7
4.3 Changing The Main Display.....	8
4.4 Setting Inlet Temperature .....	9
4.5 Sampling The Flue Gas.....	10
4.6 Taking a pressure reading.....	11
4.7 Regular Checks During Sampling .....	11
4.8 Normal Shutdown Sequence.....	12
5. MOVING THROUGH THE MENU .....	13
5.1 Basic Operation.....	14
5.2 Menu Options And Settings .....	15
5.2.1 Main Menu Options .....	15
5.2.2 Set-up Menu Options .....	18
5.3 Setting and Changing Numbers.....	20
6. PRINTING INFORMATION .....	21
6.1 Printing a 'Live' Test.....	21
6.2 Standard Printout .....	22
6.3 Pressure Temperature Mode Printout.....	22
6.4 Printer Header .....	23

7. STORING AND RETRIEVING DATA.....	25
7.1 Storing a ‘Live’ Test.....	25
7.2 Viewing and Printing a ‘Stored’ Test.....	26
7.3 Clearing Logged Data.....	27
8. MAINTENANCE.....	28
8.1 Emptying And Cleaning The In-Line Water Trap.....	28
8.2 Changing The Particle Filter.....	29
9. PROBLEM SOLVING.....	30
10. ANNUAL RE-CALIBRATION.....	30
11. PRODUCT SPECIFICATION.....	31
<b>APPENDICES: .....</b>	<b>32</b>
A. MAIN PARAMETERS .....	32
B. COMBUSTION EFFICIENCY CALCULATION .....	34
C. OXYGEN REFERENCE.....	36
D. ELECTROMAGNETIC CAPATIBILITY (EMC) STATEMENT .....	37
E. PROTECTION AGAINST ELECTRIC SHOCK .....	38

# 1 ANALYSER LAYOUT AND FEATURES

## 1.1 INSTRUMENT FEATURES AND KEYPAD



### **ON / OFF**

Turns analyser ON and OFF



### **MENU**

Allows access to all menu functions

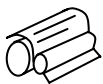

### **PRINT**

Print 'live' or stored data



### **BACK-LIGHT**

Hold to toggle back-light ON or OFF



### **STORE**

Access the data memory menu



### **PUMP**

Turns pump ON and OFF

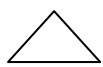

### **UP**

Changes TOP line of display.  
See also Section 5.1



### **ENTER**

Changes BOTTOM two lines of display.  
See also Section 5.1

## 1.2 STANDARD PROBE CONFIGURATION

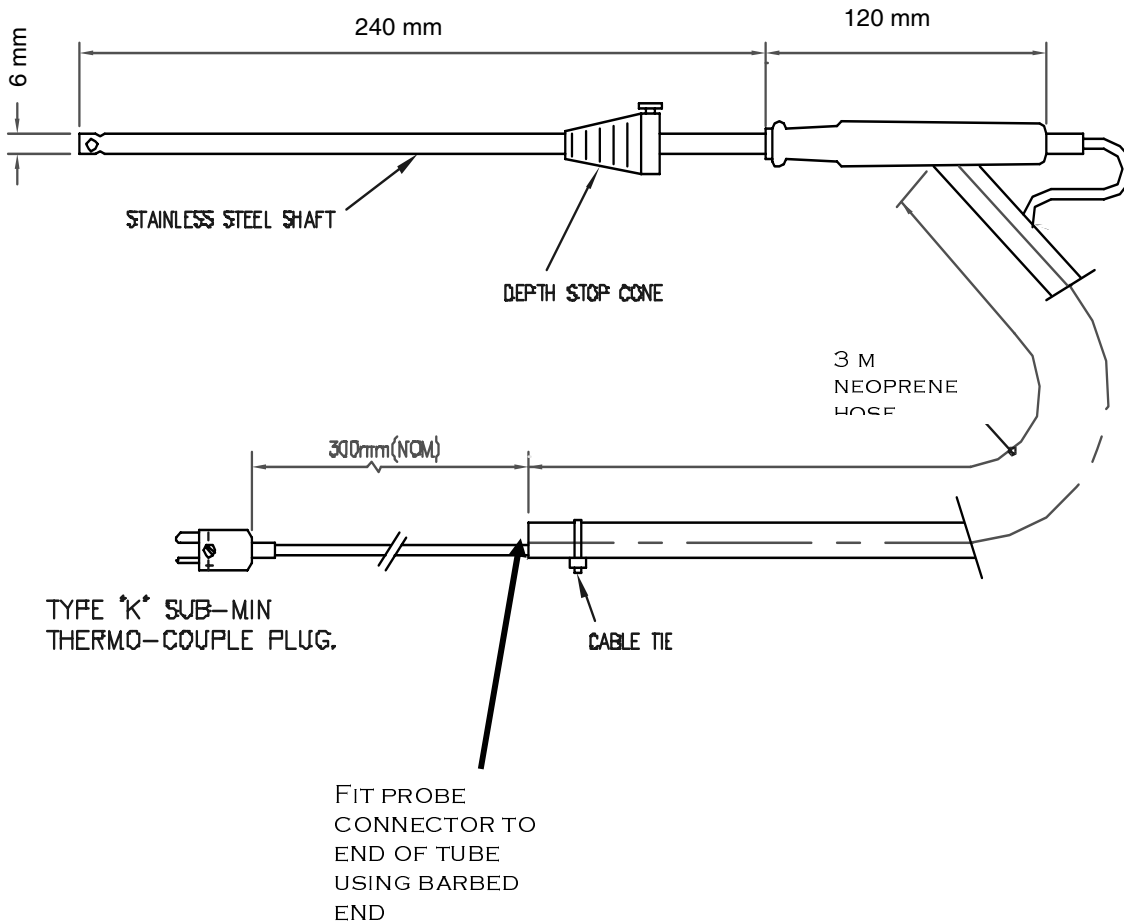

**TIP** When the probe is not in use the depth stop cone can be used to protect the tip of the probe.

**TIP** Allow the probe shaft & depth stop cone sufficient time to cool down before handling.

**NOTE!** The standard flue probe is rated up to 600°C (1112°F)

### 1.3 ANALYSER CONNECTIONS

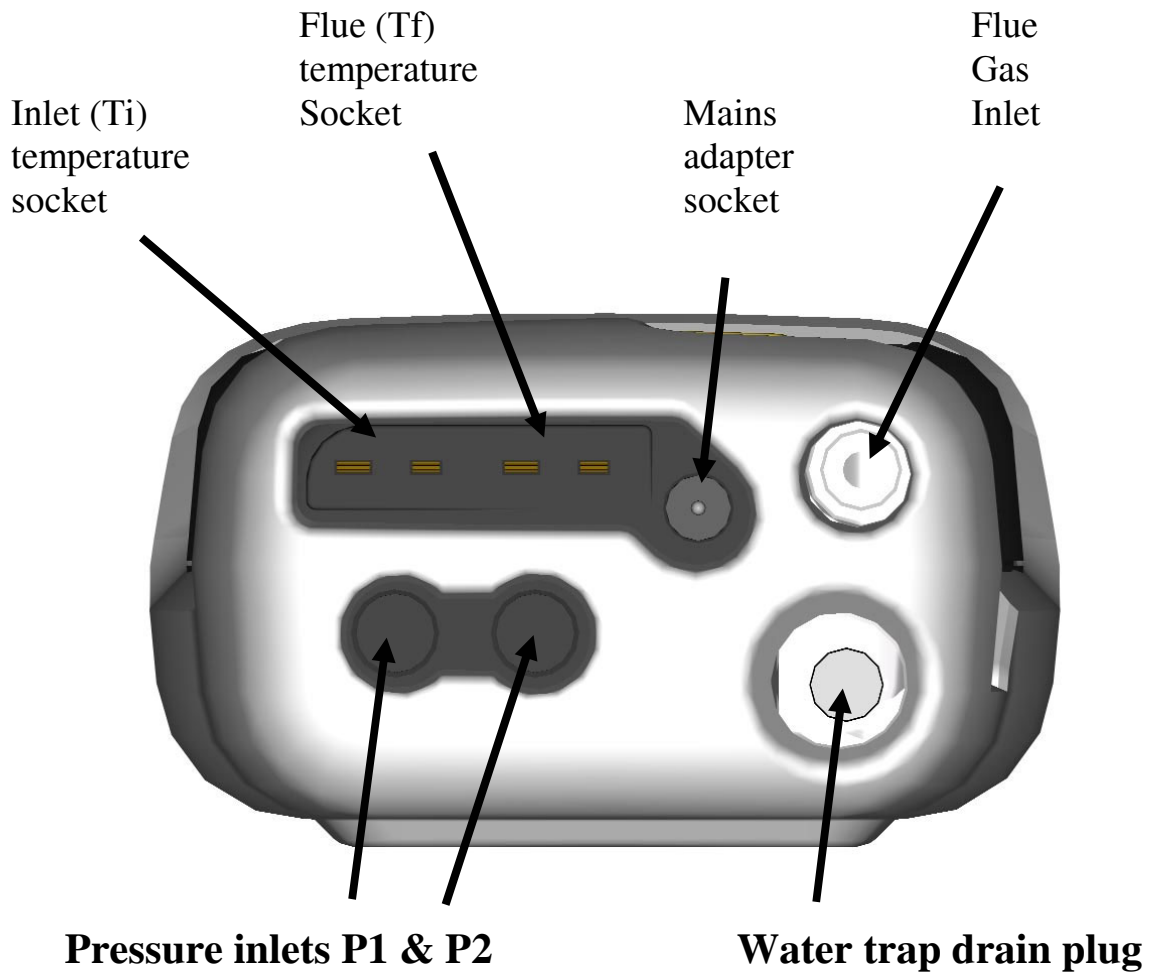

**Note!** Take care when inserting the temperature probes as the pins are polarised. Insert with the smaller pin (+) to the right. A view of the socket is shown below.

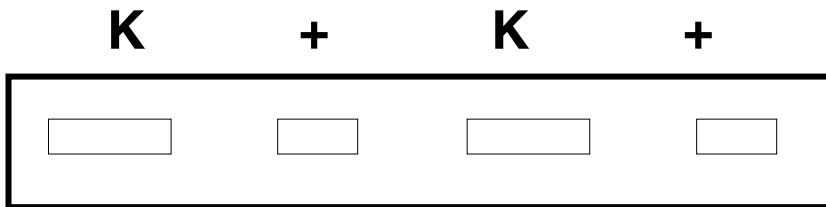



## 2. SAFETY WARNING

This analyser extracts combustion gases that may be toxic in relatively low concentrations. These gases are exhausted from the back of the instrument. ***This instrument must only be used in well-ventilated locations. It must only be used by trained and competent persons after due consideration of all the potential hazards.***

## 3. FIRST TIME USE

Check that you have all the items you have ordered.

Take time to read this manual fully.

### 3.1 INSTALLING BATTERIES

The KANE 400 is supplied with 4 AA size alkaline batteries. These should be installed into the instrument as shown below and indicated on the back of the unit:

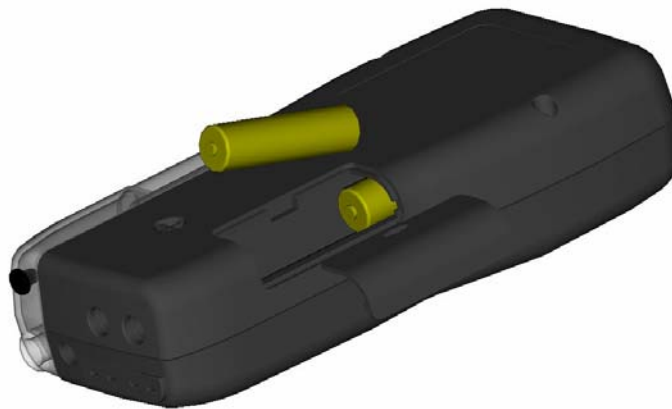

See Appendix A - Main Parameters for the Battery Level Indicator.

An optional AC adapter can be supplied to power the analyser.

Rechargeable batteries can be used in the instrument but will normally give a lower running time than alkaline. Note the AC adapter cannot be used to charge batteries in the instrument and an external charger should be used.

## 4. NORMAL START UP SEQUENCE

### 4.1 EVERY TIME YOU USE THE ANALYSER

BEFORE SWITCH-ON CHECK THAT:

- The particle filter is not dirty
- The water trap and probe line are empty of water
- All hose and thermocouple connections are properly made
- The flue gas probe is sampling ambient FRESH air
- The water trap is fitted correctly to the instrument including drain plug
- The flue temperature plug is connected
- The inlet temperature probe is connected if required

Switch ON the instrument by pressing 

After switch-on the analyser will briefly light all segments on the display as shown below:

This allows the display to be checked for correct operation, if any segments appear to be missing then the unit should be returned for repair.



**Note!** The software version number is displayed following the display check.

## 4.2 AUTOMATIC CALIBRATION

During this sequence the analyser pumps fresh air into the Oxygen and CO (if fitted) sensors to allow them to be set to 20.9 % and zero respectively. See **Section 4.4. - Setting Inlet Temperature** for information on options.

The display will show the countdown screen:

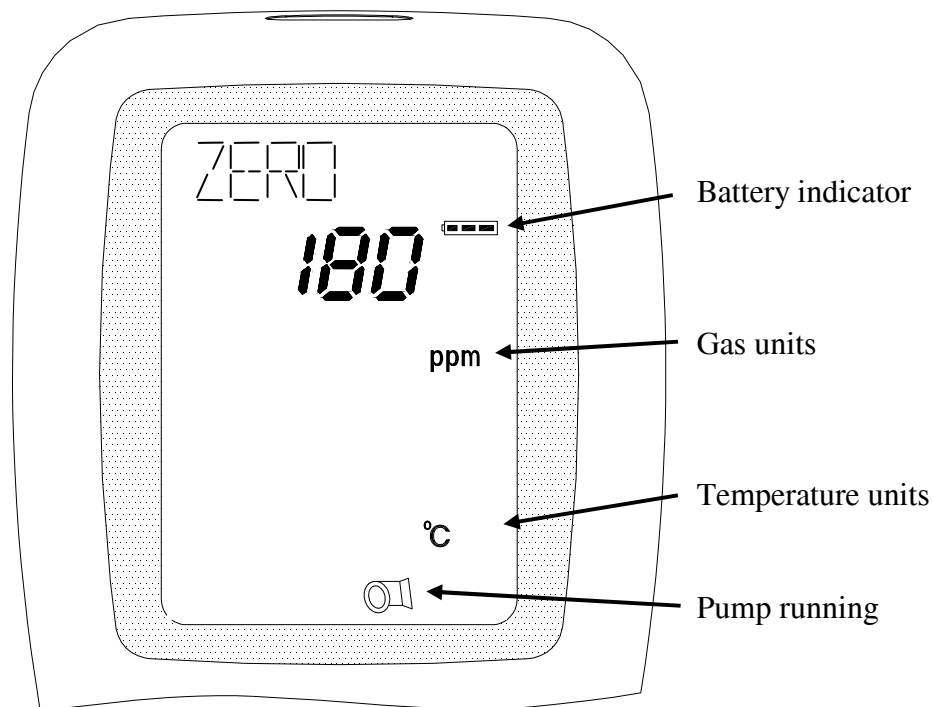

The calibration time will count down in seconds to zero and is pre-set to 180 seconds. Ensure the probe is sampling fresh air during this sequence. Note the pump key is disabled during this sequence.

### 4.2.1 QUICK AUTOZERO

When the instrument decides that it is ready to begin measurements, it terminates its autozero phase early. This generally happens some twenty seconds into the autozero phase at a countdown of about 160 instead of 0 for the full countdown.

At any time during the countdown the menu system can be entered to allow the analyser's settings to be altered. See section 5 – Moving through the menus.

Once the countdown has reached zero or the sensors are within pre-determined limits the screen shows the main display:

**TYPICAL  
MAIN  
DISPLAY**



#### **4.2.2 PRESSURE AND TEMPERATURE MODE (PTM)**

It is possible to take temperature and pressure measurements without entering the 'gas' mode. This allows the user to make these measurements without having to wait for the instrument to calibrate the gas sensors.

To enter the Pressure and Temperature Mode (PTM) with the instrument off, hold down the ENTER key, then press 1/0.

To exit the PTM, press 1/0. If you are in the PTM and wish to enter the normal 'gas' mode, you need to switch off and then switch on in the 'gas' mode.

Displays available in the PTM are a subset of the full display, viz they exclude all the gas screens. So the top two lines show only pressure, time and date; and the bottom line flue, inlet and net temperatures. The menu however still allows full access to all parameters, gas included.

**NOTE!** In this mode a printout will only include the PTM information.

### 4.3 CHANGING THE MAIN DISPLAY

The Main Display can be configured to read three parameters at the same time. The text display and top numerical display are changed independently of the other two displays. **Appendix A - Main Display Parameters** gives information on each parameter.

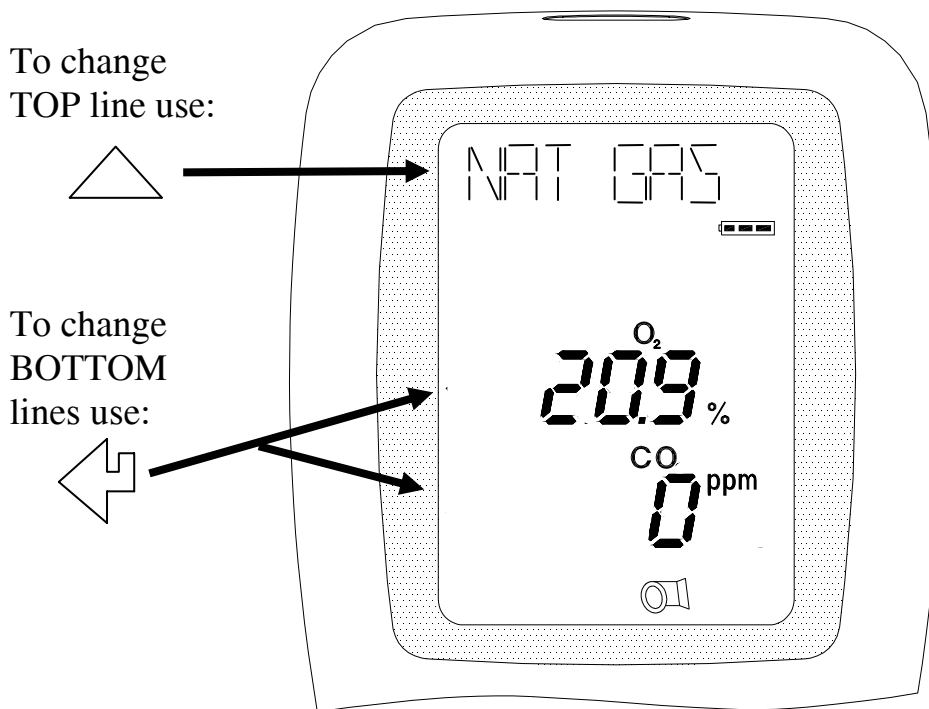

The parameters on the text line and top numerical display are selected from the following:

Text display	Numerical display	Description
NAT GAS	No display	Fuel indicator <ul style="list-style-type: none"> <li>• NAT GAS      Natural Gas</li> <li>• PROPANE</li> <li>• BUTANE</li> <li>• L OIL      Light Oil</li> <li>• LPG      Liquid Petroleum Gas</li> </ul>
EFF G %	100.00	Efficiency (gross or net)
X AIR %	100.00	Excess air
TIME	12 :45	Current time
DATE 00	17 .03	Current date (year on text display)
PRS mBAR	100.00	Draft or differential pressure reading (option)
CO PPMn	0000	Carbon Monoxide (referenced to O <sub>2</sub> )
PI	0 %	Poison Index

The middle and bottom numerical displays are changed in the following pairs:

<b>Text display</b>	<b>Units</b>	<b>Description</b>
O <sub>2</sub> and CO	% and ppm or mg/m <sup>3</sup>	Oxygen percentage and CO concentration
CO <sub>2</sub> and ΔT	% and °C or °F	Calculated CO <sub>2</sub> and Temperature Differential (net)
O <sub>2</sub> and Tf	% and °C or °F	O <sub>2</sub> and Flue Temperature
CO <sub>2</sub> and Ti	% and °C or °F	Calculated CO <sub>2</sub> and Inlet Temperature
CO/CO <sub>2</sub> and CO	Ratio and ppm or mg/m <sup>3</sup>	Ratio of CO to CO <sub>2</sub> and CO Concentration

#### **4.4 SETTING INLET TEMPERATURE**

During the Automatic calibration sequence the burner INLET (Ti) temperature used in the NET temperature calculation is stored in the analyser. There are three methods of storing the INLET temperature.

- A. Without the flue probe connected temperature inside the analyser is used
- B. If the flue probe is connected and the flue temperature is below 60° Centigrade, the temperature of the probe tip is used. This can be useful when the temperature of the air entering the burner is different from the ambient temperature of the room.
- C. With an inlet probe fitted the ambient temperature is continuously measured. Position the tip of the inlet probe at the air inlet to the burner during combustion tests

**WARNING** If the INLET temperature is set incorrectly then errors will be made in the calculation of the Nett temperature and Efficiency.

## 4.5 SAMPLING THE FLUE GAS

Once the automatic calibration procedure has been completed and the specific fuel has been selected (See **MENU** options) the probe can be inserted into the desired sampling point.

It is recommended that the sampling point be located at least two flue diameters downstream of any bend, as close to the source as possible, and that the probe tip is in the centre of the flue. With balanced flues and other domestic units the probe should be positioned far enough into the flue so that no air can 'back flush' into the probe.

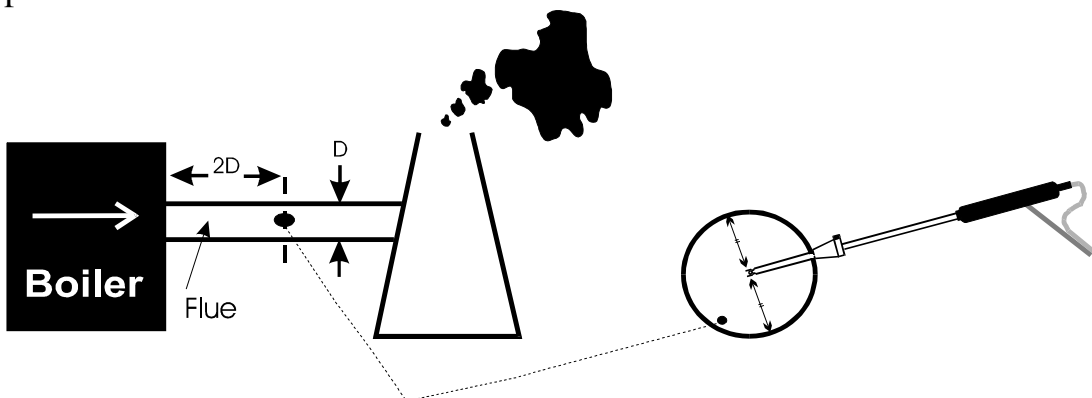

The probe depth stop cone provided with the instrument allows the probe to be used in holes whose diameters range from 6 mm to 21 mm ( $\frac{1}{4}$  to  $\frac{4}{5}$  inch).

The standard probe is rated up to 600°C (1112°F).

**TIP** To conserve battery power, switch off the pump when you are not taking a measurement. To turn pump ON and OFF press 

**TIP** By turning the pump off the readings can be held so they can be printed. See section **5.2.1 Main Menu Options, Pump Hold**, for information.

If the CO level is more than 4000ppm, then the CO alarm will operate, the instrument will display CO HIGH and the pump will pulse off to give an audio indication.

## 4.6 TAKING A PRESSURE READING

An optional differential pressure sensor is available for the KANE 400. With this option a flue draft measurement can be made or a differential pressure test made.

To take a flue draft reading, connect the standard probe to the pressure sensor inlet P1 and insert the probe in the flue.

Select PRS on the text line of the screen as indicated:



To take a differential pressure reading, apply positive pressure to P1 and differential side to P2.

**TIP** To zero the pressure sensor see **Section 5.2.1, Main Menu Options, Reset**, for information.

## 4.7 REGULAR CHECKS DURING SAMPLING

Care must be taken at all times not to exceed the analyser's operating specifications. In particular ensure the following:

- Do not exceed the maximum temperature of the flue probe.
- The analyser internal temperature does not exceed normal operating range.
- DO NOT PLACE THE INSTRUMENT ON A HOT SURFACE.
- The water trap is correctly attached at all times. Water condenses in the probe line and can quickly fill the water trap when the probe is moved. Take care and watch the water trap closely.
- The particle filter is clean and does not become blocked.
- Do not exceed maximum pressure range of pressure sensor.

## 4.8 NORMAL SHUTDOWN SEQUENCE

DO THIS EVERY TIME YOU USE THE ANALYSER

### **WARNING! THE PROBE WILL BE HOT FROM FLUE GASES**

Remove the probe from the flue and allow it to cool naturally. Do not immerse the probe in water, as this will be drawn into the analyser and damage the pump and sensors. Once the probe is removed from the flue and the readings have returned to ambient levels hold down  and switch off the analyser.

The instrument will count down from 30 to switch off and display the following screen.



If you press  by mistake  will return you to normal operation.

**Note!** The analyser will not allow shut down if the flue temperature is higher than 60° Centigrade (140°F), the oxygen level is less than 20% or the CO level is greater than 20 ppm.

## 5. MOVING THROUGH THE MENU

The options in the menu system are in the following sequence:

- Fuel selection
- Pump / data hold feature
- Reset
- Pressure units
- Oxygen reference
- Temperature units
- Gas units
- Efficiency calculation
- Set-up
  - Display contrast
  - Fuel table
  - Time setting
  - Date setting (including format)
  - Language
  - Header

**TIP** In the MENU system, press  menu key one or more times to return to the Main Display.

## 5.1 BASIC OPERATION

From the MAIN DISPLAY press  to access the MENU system.

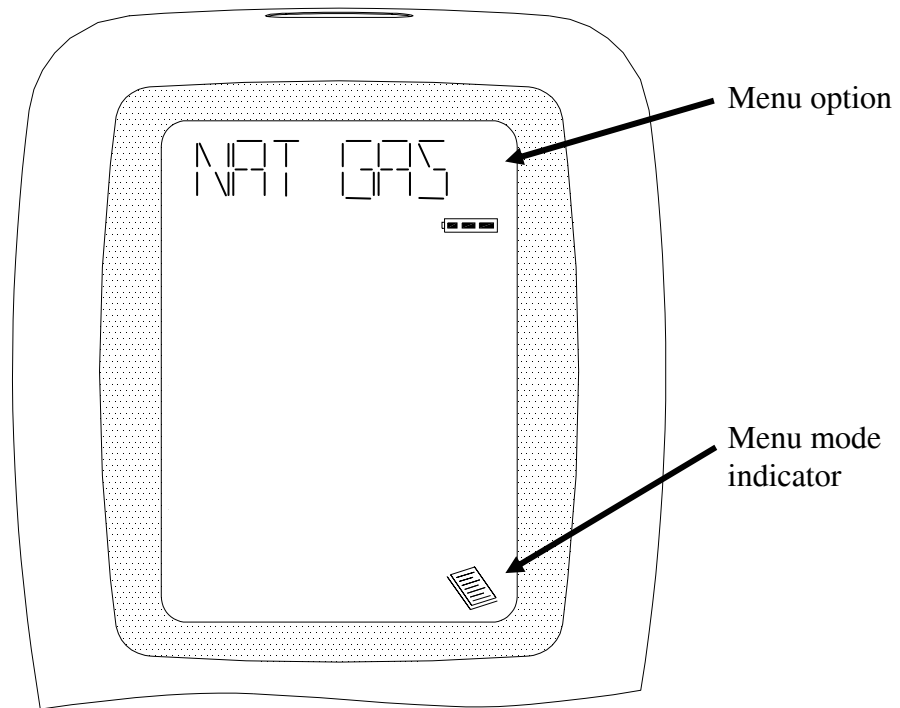

Use  to scroll through the fuel options

NAT GAS



PROPANE

Press  to accept the selection  
And move to next menu option

HOLD ON

Use  to scroll through options

HOLD OFF

Press  to proceed to the next option or  
press  to return to the MAIN DISPLAY

## 5.2 MENU OPTIONS AND SETTINGS

### 5.2.1 MAIN MENU OPTIONS

	<b>DESCRIPTION</b>	<b>DISPLAYED</b>
<b>FUEL</b>	Select the fuel being used by the boiler from list of standard fuels:	
	Natural Gas	NAT GAS
	Propane	PROPANE
	Butane	BUTANE
	Light Oil	LIGHTOIL
	Liquid Petroleum Gas	LPG

**PUMP HOLD** An option when turning the pump off is to freeze the current readings so that they can be printed after the probe has been removed from the flue.



Freezes display when pump turned off	HOLD ON
Display updates with actual readings	HOLD OFF

**Warning!** Turning the pump off while the probe is in the flue will leave toxic gases inside the analyser. Once data has been printed or copied it is advisable to purge the unit with fresh air as soon as possible. To do this, with the probe removed from the flue, turn ON the pump.

	<b>DESCRIPTION</b>	<b>DISPLAYED</b>
<b>RESET</b>	Resets the pressure readings to zero.	RESET
	To use this facility ensure that the pressure ports of the analyser are at atmospheric pressure, then press  . The display then asks for confirmation, press store key to zero pressure readings, or any other key to retain the previous reading. After zeroing, the display returns to RESET.	

	<b>DESCRIPTION</b>	<b>DISPLAYED</b>
<b>PRESSURE</b>	Changes the units of the pressure readings from:	
	<b>millibar</b>	PR5 mBAR
	<b>InWG</b>	PR5 INWG
	<b>mmWG</b>	PR5 mmWG
	<b>hPa</b>	PR5 hPa

	<b>DESCRIPTION</b>	<b>DISPLAYED</b>
<b>O2 REF</b>	Toxic gas measurements can be referenced to defined oxygen levels. Reference values can be set from 0-20% Oxygen Referencing is detailed in Appendix C.	O2 REF

The value of the oxygen reference is shown on the top numerical display. The default value is set to 3%. To change the value use  and . See section **5.3 Setting and changing numbers**.

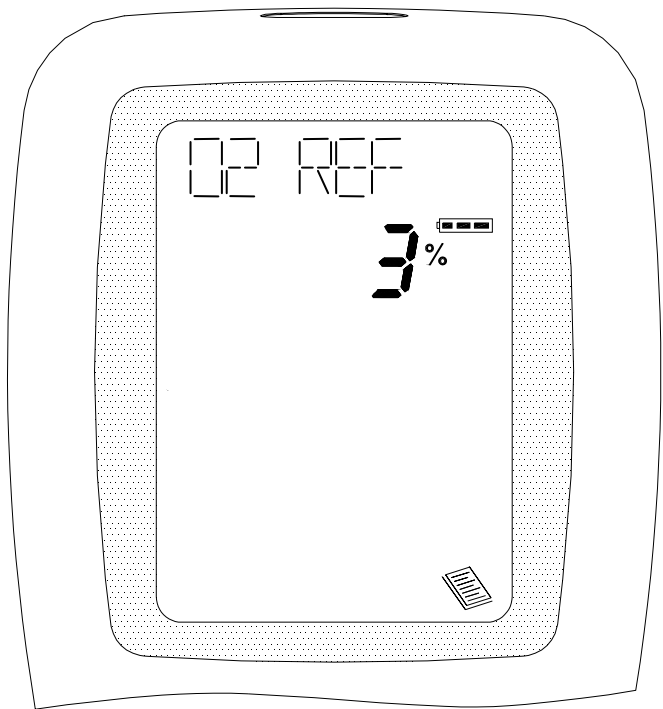

<b>TEMPERATURE UNITS</b>	<b>DESCRIPTION</b>	<b>DISPLAYED</b>
	Temperature readings displayed in:	

Centigrade C	TEMP C
Fahrenheit F	TEMP F

<b>GAS UNITS</b>	<b>DESCRIPTION</b>	<b>DISPLAYED</b>
	Gas measurement unit can be changed from:	

Parts per million (ppm)	GAS PPM
-------------------------	---------



Milligrams per metre cubed (mg/m <sup>3</sup> )	GAS mgm3
---	----------

<b>EFFICIENCY CALCULATION</b>	<b>DESCRIPTION</b>	<b>DISPLAYED</b>
	Efficiency can be selected for Gross or Nett values. Gross efficiency assumes latent heat of vaporisation is lost in the boiler and hence will be lower than Nett efficiency. For Natural Gas the difference will be approximately 11%.	

See Appendix B for further details.

Gross	EFF G
Nett	EFF N

## 5.2.2 SET-UP MENU OPTIONS

	DESCRIPTION	DISPLAYED
<b>SET UP</b>	Enter a sub menu to change the time, date and language setting.  To accept the current set-up press   to change the setting press  to enter the set up sub-menu:	SET UP

As with the main menu system the set up sub-menu system operates in the same way. First option in the **SET UP** menu is:

<b>CONTRAST</b>	The contrast is set to a default value or can be adjusted. Note the screen may jump from dark to clear.	To adjust, hold 
<b>FUEL TABLE</b>	Different countries have different types of fuel and different efficiency calculations. Choose from the following:	<p><b>UK</b> UK FUEL</p> <p><b>North America</b> USA FUEL</p> <p><b>Etc.</b></p>

Other fuel tables included in the analyser are Spain (ESP), France (FR), Italian (IT), Netherlands (NE), Portugal (PORT) and Finland (SU).

The next five options require a number to be set. See section **5.3 Setting and changing numbers**.

<b>HOURS</b>	Input the time in hours.	HOURS
<b>MINUTES</b>	Input the time in minutes.	MINUTES
<b>YEAR</b>	Input the year.	YEAR
<b>MONTH</b>	Input the month of the year.	MONTH
<b>DAY</b>	Input the day of the month.	DAY
<b>FORMAT</b>	Change the printed format of the date.	TTMM--YY JJ--MM--YY MM--JJ--YY YY--MM--JJ
<b>LANGUAGE</b>	Change the language:	
	<b>English</b>	ENGLISH
	<b>Spanish</b>	ESPAÑOL
	<b>French</b>	FRANCAIS



Other languages are also included.

**NOTE!** To change the printout header, refer to **Section 6.3, Printout Header**.

### 5.3 SETTING AND CHANGING NUMBERS

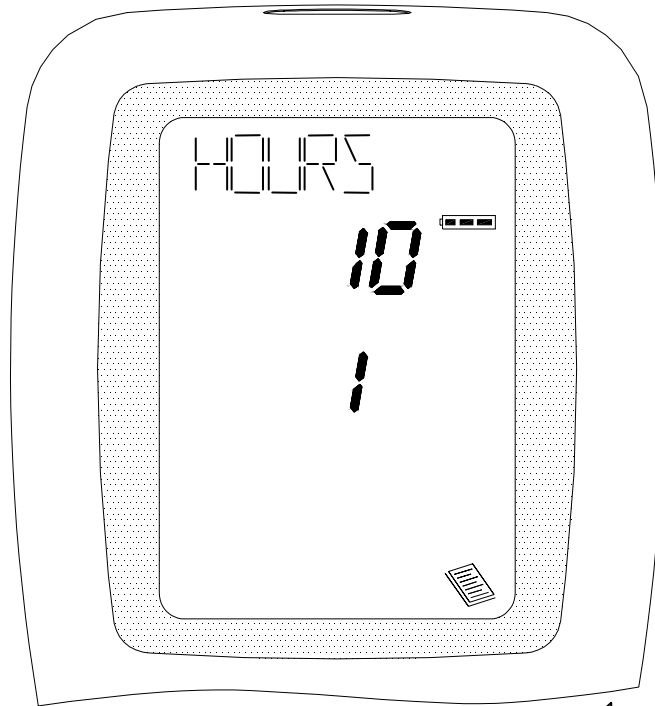
Once the number changing sequence is initiated from one of the menu options i.e. hours, below the current setting a digit will appear. This digit on the second line of the display indicates that is the number to be changed. The screen below indicates that the one of ten o'clock can be changed.



Use the  key to select the correct number and press  when correct. To change the time to 23 change the one to two and then the zero to three as shown below:

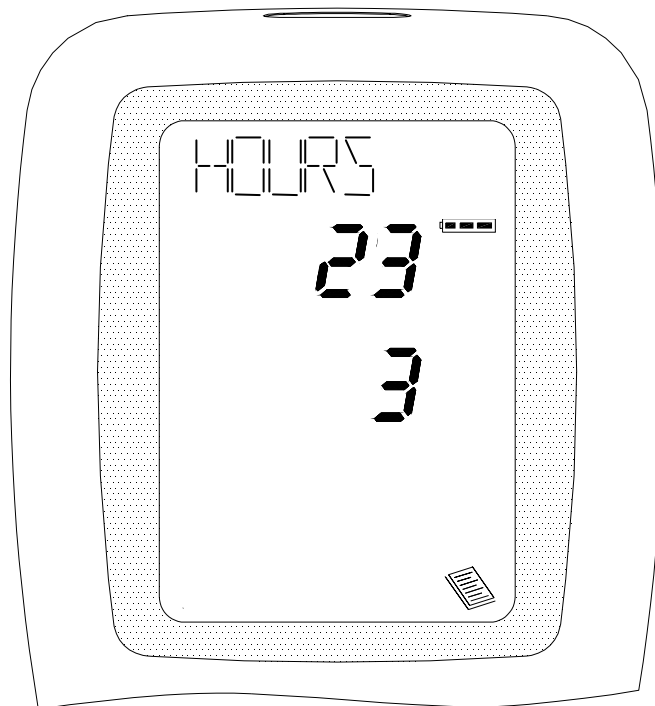

Press  to accept the final value and move to the next menu option.

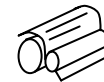

## 6. PRINTING INFORMATION

Supplied as an accessory for the KANE 400 is an infra-red thermal printer. Read the manual supplied with the printer before operation. Connection to the KANE 400 is detailed below:

- Infra-red thermal printer - this does not require a cable to transmit the data but uses an infra-red (IR) link similar to a TV remote control. The IR emitter is positioned on the top of the KANE 400 and the bottom of the printer. Ensure they are pointing at each other and within 1 meter, with no obstructions in the way. Data may be lost if transmission is interrupted. Keep the KANE 400 pointing at the printer until the printout has finished.

Data can either be printed from a 'live' test or from stored data. Printing of stored data is detailed in **SECTION 7, STORING AND RETRIEVING DATA.**

### 6.1 PRINTING A 'LIVE' TEST

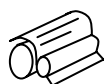
During a combustion test the KANE 400 will print data on request. With the analyser showing the MAIN DISPLAY press  and current data will be sent to the printer.

The display will show the following until data transmission is complete.

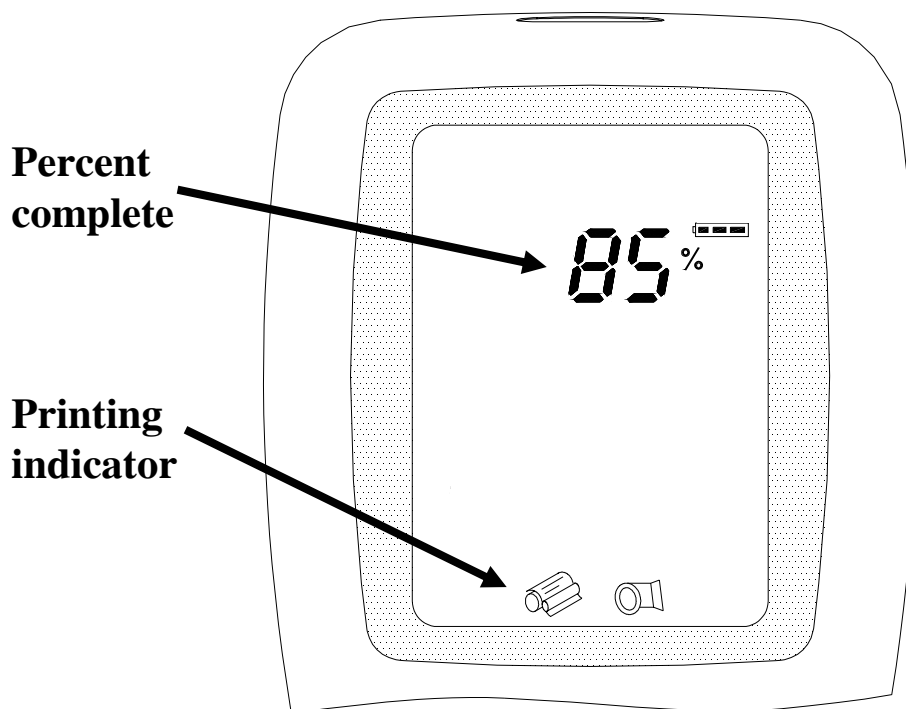

## 6.2 STANDARD PRINTOUT

The standard printout is shown

YOUR NAME AND TELEPHONE NUMBER HERE		
VIEW		2
12-03-02		15:16
SMOKE :		
NAT GAS		
O2	%	13.5
CO2	%	4.2
CO	ppm	14
EFF G	%	84.64
NET	°C	59.2
FLUE .	°C	80.0
INLET	°C	20.8
CO/CO2		0.000
X AIR	%	183.52
CO	ppmn	33
O2 REF	%	3.0
PRS	mbar	0.04
*****		

## 6.3 PRESSURE TEMPERATURE MODE PRINTOUT

The pressure temperature mode printout is shown :-

YOUR NAME AND TELEPHONE NUMBER HERE		
VIEW		2
12-03-02		15:16
NET	°C	13
FLUE .	°C	42
INLET	°C	29
PRS	mbar	0.00
*****		

## 6.4 PRINTER HEADER

### Printer Header

Allows two lines of 24 characters to be programmed into the analyser. The header appears on the top of the standard printout. This can be used to print your company name and/or phone number.

To change the header:

From the user display screen (screen after switch on) Press **MENU**



Scroll through the menu using **ENTER**  until SETUP is displayed



Press **UP**

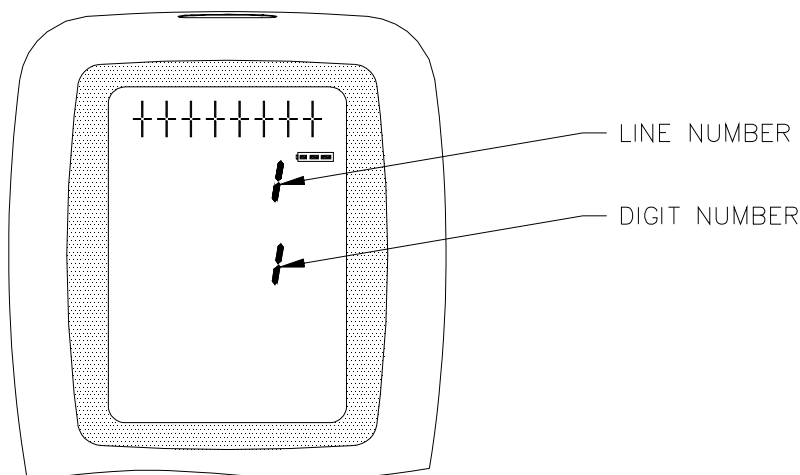

Scroll through the menu using **ENTER**  until HEADER is displayed

Press **UP**  for the screen shown below to be displayed



By using **UP**  and **STORE**  , any letter or number can be chosen from the following list:

**ABCDEFGHIJKLMNOPQRSTUVWXYZ**

**0123456789 ' space**

When the correct character is displayed, press **ENTER**  to move to the next digit.

Continue entering characters for the required name or telephone number to be displayed

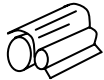
To return to edit a character, press **PRINT** 

Press **MENU**  three times to return to the user display

## 7. STORING AND RETRIEVING DATA

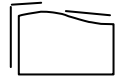

The KANE 400 can store up to 99 combustion tests. Once stored, the data can be viewed on the display or downloaded to the infra-red printer.

Options in the store menu are:

- **STORE** - Allows data to be stored in memory.
- **VIEW** - Stored data can be viewed or printed.
- **DATA** - Clears all data in memory.

Note! At any time in the store menu press  to exit.

### 7.1 STORING A 'LIVE' TEST

While performing a test and viewing the data on the MAIN display access the STORE menu by pressing 



**TIP :**

Make a note of the **location number** for your particular test as it may be useful when printing.

To record a test set to **STORE** and press . The current readings will be stored in the analysers memory. The analyser will return to the MAIN DISPLAY.

**Note!** The display above shows the location the live test will be stored in the memory of the analyser on the top numerical line. The bottom two lines are active flue gas readings.



### 7.3 VIEWING AND PRINTING A 'STORED' TEST

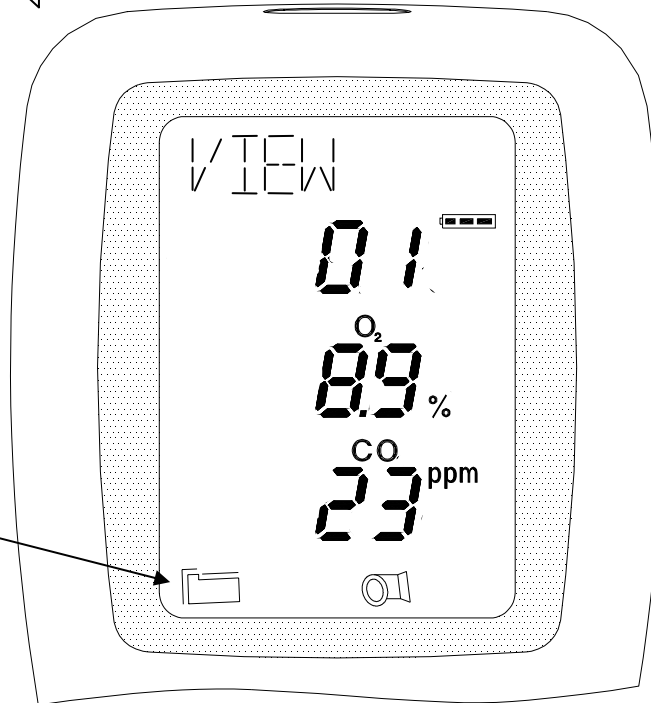

To retrieve a stored test from memory access the STORE menu by pressing 

Select VIEW using 

To indicate the data on the display is stored this symbol will be lit



Use  and  to select the location number to view. See section 5.3 Setting and changing numbers.

As with the main display use  and  to control the top and bottom two rows of data.

To print this location press 

To select another location in memory press  the view screen will be displayed.

Press  to return to the MAIN DISPLAY.

**NOTE!** Viewing stored readings uses the current value for the oxygen reference rather than the stored value.

## 7.4 CLEARING LOGGED DATA

To delete the data in stored memory press  to enter the STORE MENU (as above) :-

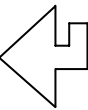
Use  to select DELETE

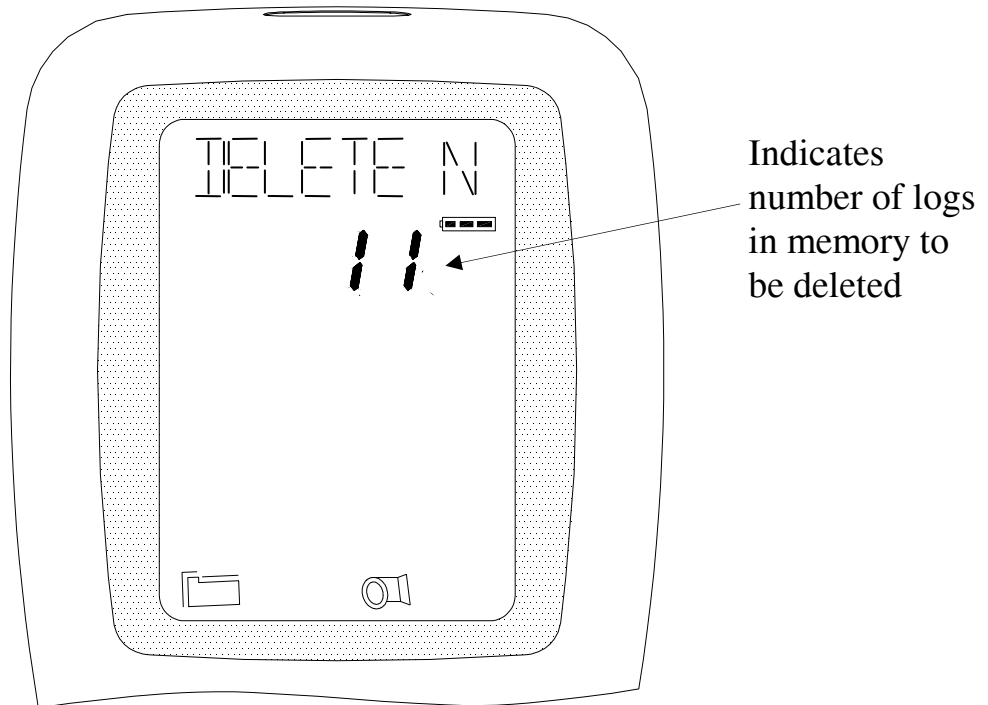



Use  to select DELETE Y and press .

Note! To exit at this point select DELETE N or press .

If DELETE Y is selected a message will scroll on the screen to ensure you wish to delete all of the data in memory.

PRESS STORE TO DELETE

Press  to delete data in memory, press  to exit delete data screen.

## 8. MAINTENANCE

### 8.1 EMPTYING AND CLEANING THE IN-LINE WATER TRAP

The in-line water trap should be checked and emptied on a regular basis. Water vapour will condense in the probe line, which may cause the water trap to fill suddenly if the probe is moved. Care should be taken at all times.

Emptying of the water trap is detailed below: -

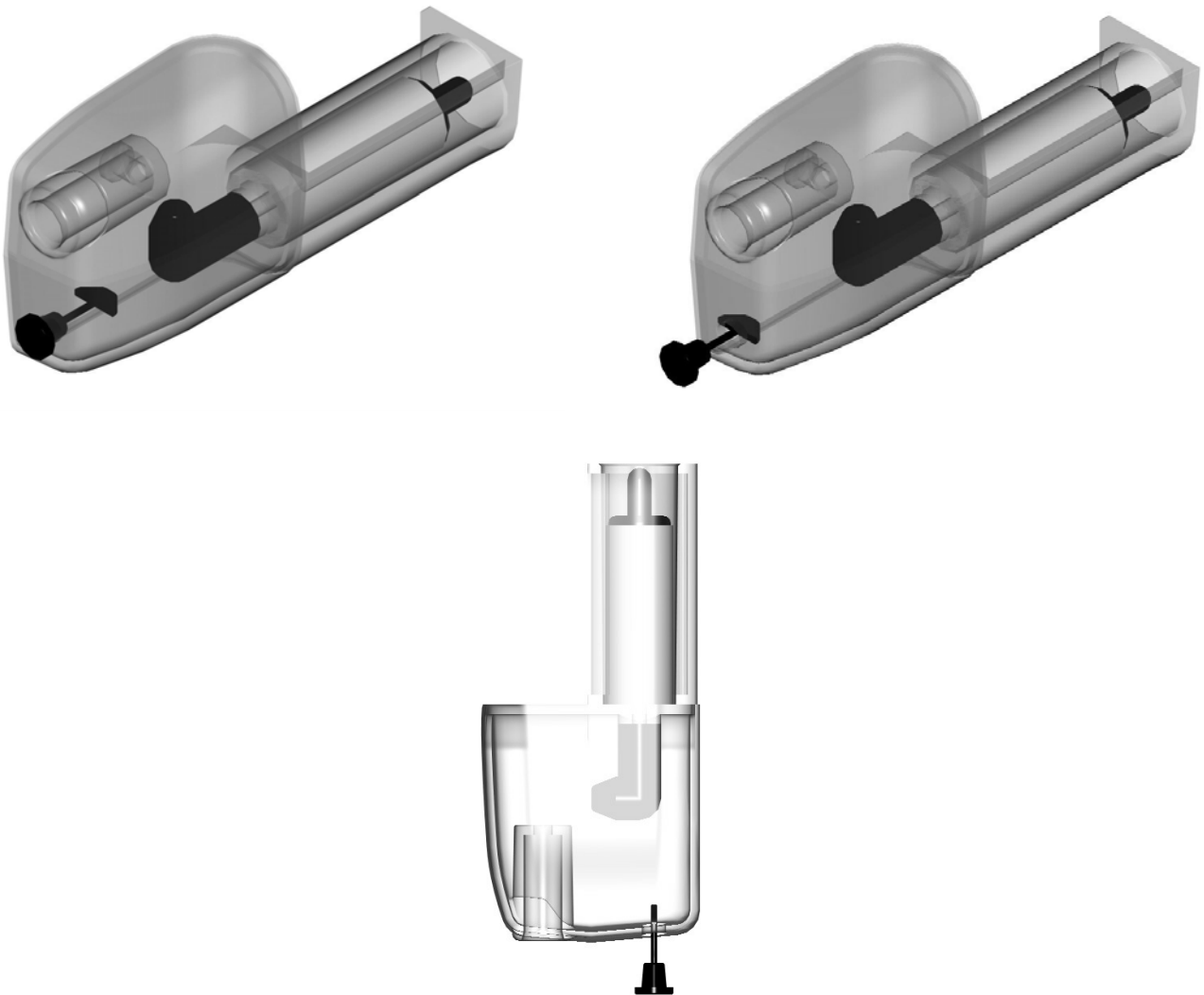

Carefully remove the rubber plug from the bottom of the water-trap housing. Dispose of the condensate in a suitable drain, care must be taken as it could be acidic.

If condensate spills onto the skin or clothing, clean off immediately using fresh water, seek medical advice if problems occur. Ensure plug is replaced before performing further combustion tests.

## 8.2 CHANGING THE PARTICLE FILTER

This is a very important part of the analyser and should be changed regularly. It prevents dust and dirt particles from entering the pump and sensors that will cause damage. The filter **MUST** be changed when it appears discoloured.



Remove water-trap assembly from the analyser as shown above. Remove the filter and plastic holder from the housing. Discard the filter element but keep the holder to fit to the new filter. Clean the inside of the filter housing with a suitable soft cloth. Fit the holder onto the new filter element and then insert into the housing. Refit the housing onto the analyser.

**TIP** It is the inner surface of the filter that becomes discoloured.

## 9. PROBLEM SOLVING

The following is a list of problems that may occur on the instrument through its operating life. If the cause of the fault is not easy to identify then we advise you contact the Kane International Ltd or an approved Service Agent.

<b>Fault symptom</b>	<b>Causes</b>
<ul style="list-style-type: none"> <li>• Oxygen too high</li> <li>• CO<sub>2</sub> too low</li> </ul>	<ul style="list-style-type: none"> <li>• Air leaking into probe, tubing, water trap, connectors or internal to instrument.</li> <li>• Oxygen cell needs replacing.</li> </ul>
<ul style="list-style-type: none"> <li>• Oxygen Error (- - - -)</li> <li>• CO sensor Error (- - - -)</li> </ul>	<ul style="list-style-type: none"> <li>• Instrument has been stored in a cold environment and is not at normal working temperature.</li> <li>• Oxygen cell or CO sensor needs replacing.</li> </ul>
<ul style="list-style-type: none"> <li>• Batteries not holding charge</li> <li>• Analyser not running on mains adapter.</li> </ul>	<ul style="list-style-type: none"> <li>• Batteries exhausted.</li> <li>• AC charger not giving correct output.</li> <li>• Fuse blown in charger plug.</li> </ul>
<ul style="list-style-type: none"> <li>• Analyser does not respond to flue gas</li> </ul>	<ul style="list-style-type: none"> <li>• Particle filter blocked.</li> <li>• Probe or tubing blocked.</li> <li>• Pump not working or damaged with contaminants.</li> </ul>
<ul style="list-style-type: none"> <li>• Net temperature or Efficiency calculation incorrect.</li> </ul>	<ul style="list-style-type: none"> <li>• Ambient temperature set wrong during Automatic Calibration.</li> </ul>
<ul style="list-style-type: none"> <li>• Flue temperature readings erratic</li> </ul>	<ul style="list-style-type: none"> <li>• Temperature plug reversed in socket.</li> <li>• Faulty connection or break in cable or plug.</li> </ul>
<ul style="list-style-type: none"> <li>• Instrument displays 'MEM ERR' briefly</li> </ul>	<ul style="list-style-type: none"> <li>• Memory fault.</li> <li>• Contact Kane International or approved Service Agent.</li> </ul>

## 10. ANNUAL RE-CALIBRATION

While the sensor has an expected life of more than two years in normal use it is recommended that the analyser is re-calibrated at least annually. This is so that long-term drift on the sensor and electronics can be eliminated. Local regulations may require more frequent re-calibration and users should check with appropriate authorities to ensure they comply with relevant guidelines.

## 11. PRODUCT SPECIFICATION

Parameter	Resolution	Accuracy	Range
<b>Temp Measurement</b>			
Flue Temperature	0.1°C/F	± 2°C (5.0°F) ±0.3% reading	0-600°C 32-1112°F
Inlet Temperature (Internal Sensor)	0.1°C/F	±1°C/F ±0.3% reading	0-100°C 32-212°F
Temp (Nett) *2	0.1°C/F	± 2°C (5°F) ±0.3% reading	0-600°C 32-1112°F
<b>Gas Measurement</b>			
Oxygen	0.1%	±0.2% *1	0-21%
Carbon Monoxide	1ppm	±10ppm <100ppm *1 ±5% of reading	0-2000ppm nom. 4000 ppm max for 15 minutes
Carbon Dioxide *2	0.1%	±0.3% reading	0-30%
Efficiency *2	0.1%	±1.0% reading	0-99.9%
Excess Air *2	0.1%	±0.2%	0-250%
Poison Index *2	0.1%	±5% reading	0-99.9%
CO/CO <sub>2</sub> ratio *2	0.001	±5% reading	0-0.999
Pressure (differential)	0.01 mbar (0.004 inWG 0.01 >20 inWG)	±1% of full scale	0-100 mbar (0-19.999 inWG 20-40 inWG)
<b>Pre-programmed Fuels</b>	Natural gas, Light Oil (28/35 sec), Propane, Butane, LPG.		
<b>Dimensions</b>			
Weight	1kg (2.2lb)		
Handset	200mm (7.9") x 45mm (1.8") x 90mm (3.5")		
Probe	L 300mm (11.8") x Dia 6mm (0.25") with 240mm (7.8") long stainless steel shaft, type K thermocouple and 3m (6') long neoprene hose		
<b>Ambient Operating Range</b>	0 to +40°C (+32°F to +104°F) 10% to 90% RH non- condensing		
<b>Battery Life</b>	4 AA cells >8 hours using Alkaline AA cells		
<b>AC adapters (optional)</b>	Input: 110Vac or 220 Vac nominal Output: 6.0 vdc 500mA		

\*1 Using dry gases at STP

\*2 Calculated

## APPENDICES

### A. MAIN PARAMETERS

The following section gives details of the main display parameters.

- O2 :** Oxygen reading in percentage (%)
- Tf :** Temperature is measured by the flue gas probe in Centigrade or Fahrenheit. Will show ambient temperature after fresh air calibration and ‘- - -’ if the flue probe is disconnected.
- CO:** Carbon Monoxide reading displayed in ppm (parts per million). ‘- - - -’ is displayed if there is a fault with the CO sensor or the instrument has not set to zero correctly, switch off instrument and try again.
- CO PPMN :** Carbon Monoxide reading referenced to a particular oxygen level. Do not confuse this reading with the actual CO reading as detailed above. See appendix C for more details.
- CO<sub>2</sub> :** Carbon Dioxide calculation determined by the type of fuel. This only shows a reading when a combustion test is being carried out. ‘- - - -’ is displayed while in fresh air.
- ΔT :** Net temperature calculated by deducting the **INLET** temperature from the measured **FLUE** temperature. Displays in either Centigrade (°C) or Fahrenheit (°F) and will display ‘- - - -’ if the flue probe is not connected.
- EFF (G) :** Combustion efficiency calculation displayed in percentage. Gross (G) or Net (N) can be set (see **MENU**). The calculation is determined by the fuel type and uses the calculation in British Standard BS845. The efficiency is displayed during a combustion test, ‘- - - -’ is displayed while in fresh air.
- XAIR % :** Excess air calculated from the measured oxygen and type of fuel used.  
Displays reading during a combustion test. ‘- - - -’ is displayed while in fresh air.
- Ti :** Boiler air **INLET** temperature used to calculate the **NET** temperature.

**CO/CO<sub>2</sub> :** The CO/CO<sub>2</sub> ratio is the ratio of measured CO divided by calculated CO<sub>2</sub>.

It gives an indication of:

- How good a gas sample the instrument is reading.
- How clean the boiler is running.





For example: A new or clean domestic boiler will display a ratio of less than 0.004, a unit in need of cleaning 0.004-0.008 and a unit in need of major overhaul will show greater than 0.008.

This only shows a reading when a combustion test is being carried out.

'- - -' is displayed while in fresh air.



Displays the approximate battery level as follows:

- Full battery level 
- Battery at 75% 
- Battery at 50% 
- Battery at 25% 

When the LO BAT symbol appears this indicates the batteries are at less than 10% of charge and should be replaced, readings may be affected if the analyser is used with low power batteries.

**DATE :** Date shown as day, month and year. The order can be changed using the menu function. Date is stored with a combustion test.

**TIME :** The time is shown in hours and minutes, these details are stored with each combustion test.

**PRS :** Pressure measured by the instrument. Can be displayed in mBar, mmWG, inWG or hPa.

## B. COMBUSTION EFFICIENCY CALCULATION

The efficiency calculation is based upon British Standard BS845.

This identifies three sources of loss associated with fuel burning:

**Losses due to flue gasses:** Dry Flue gas loss, Moisture and hydrogen,  
Sensible heat of water vapour, Unburned gas

**Losses due to refuse:** Combustible in ash, riddlings and dust

**Other losses:** radiation, convection, conduction  
other unmeasured losses

Net efficiency calculations assume that the energy contained in the water vapour (formed as a product of combustion and from wet fuel) is recovered and the wet loss term is zero. Gross efficiency calculations assume that the energy contained in the water vapour is not recovered.

Since the fuel air mixture is never consistent there is the possibility of unburned/partially unburned fuel passing through the flue. This is represented by the unburned carbon loss.

Losses due to combustible matter in ashes, riddlings, dust and grit, radiation, convection and conduction are not included.

### Efficiency Calculation:

Known Data - Fuel:  $Q_{gr}$  = Gross Calorific Value (kJ/kg)  
 $Q_{net}$  = Net Calorific Value (kJ/kg)  
 $K_1$  = Constant based on Gross or Net Calorific Value:  
 $K_{1g}$  = %Carbon in fuel /  $Q_{gr}$   
 $K_{1n}$  = %Carbon in fuel /  $Q_{net}$   
 $K_2$  = % max theoretical  $CO_2$  (dry basis)  
 $K_3$  = % Wet Loss  
 $H_2$  = % Hydrogen  
 $H_2O$  = % Water

Measured Data:  $T_f$  = Flue Temperature  
 $T_i$  = Inlet Temperature  
 $O_{2m}$  = % Oxygen in flue gas  
 $O_{2r}$  = Oxygen reference %

Calculated data:	Tnet = Net Temperature % CO <sub>2</sub> content in flue gas % Dry Flue Gas losses % Wet losses % Unburned carbon loss % Efficiency
<b>Tnet</b>	= Flue Temperature - Inlet Temperature
<b>Dry flue gas loss %</b>	= $20.9 \times K1 \times (Tnet) / K2 \times (20.9 - O_2m)$
<b>Wet loss %</b>	= $9 \times H_2 + H_2O / Qgr \times [2488 + 2.1Tf - 4.2 Ti]$
Simplified	= $[(9 \times H_2 + H_2O) / Qgr] \times 2425 \times [1 + 0.001 Tnet]$
Wet loss %	= $K3(1+0.001 \times Tnet)$
Where K3	= $[(9 \times H_2 + H_2O) / Qgr] \times 2425$
<b>Net Efficiency %</b>	= 100 - dry flue gas losses – unburnt fuel loss = $100 - 20.9 \times K1n \times (Tnet) / K2 \times (20.9 - O_2m) - \text{unburnt fuel loss}$
<b>Gross Efficiency %</b>	= 100 - {dry flue gas losses + wet losses} – unburnt fuel loss = $100 - \{[20.9 \times K1g \times (Tnet) / K2 \times (20.9 - O_2m)] + [K3 \times (1 + 0.001 \times Tnet)]\} - \text{unburnt fuel loss}$
<b>Excess Air</b>	= $[20.9 / (20.9 - O_2m) - 1] \times 100$
<b>CO<sub>2</sub> %</b>	= $[(20.9 - O_2m) \times K2 / 20.9]$
<b>Unburned fuel Loss %</b>	= $K4 \times CO / (CO + CO_2)$ Note: CO scaled in %
Where K4	= 70 for coke = 65 for anthracite = 63 for Bituminous coal = 62 for coal tar fuel = 48 for liquid petroleum fuel = 32 for natural gas

The formula for K4 is based on the gross calorific value Qgr. To obtain the loss based on net calorific value multiply by Qgr/Qnet. This loss is subtracted from the efficiency.

## C. OXYGEN REFERENCE AND CONVERTING TO mg/m<sup>3</sup>

Oxygen referencing is required by some regulations such as TA-LUFT. If a reference value is selected then the CO gas measurement will be displayed with the symbol (**n**) attached to the reading. i.e. PPM<sub>n</sub>

What does Oxygen reference mean?

If 3 % O<sub>2</sub> reference (O<sub>2r</sub>) is selected and 5 % O<sub>2</sub> is measured (O<sub>2m</sub>) in the flue then the CO gas value will be recalculated as if 3 % were measured. The equation for referencing is as follows :-

$$\text{CO PPM}_n = \text{CO PPM} \times (20.9 - \text{O}_{2r}) / (20.9 - \text{O}_{2m})$$

In our example if a reading of 95 PPM were measured then the referenced value would be calculated as follows: -

$$\text{CO PPM}_n = 95 \text{ PPM} \times (20.9 - 3) / (20.9 - 5)$$

$$\text{CO PPM}_n = 95 \text{ PPM} \times (17.9) / (15.9)$$

$$\text{CO PPM}_n = 107$$

We may be given a limit on our boiler by the local authority which stated that we must not emit more than 100 PPM Carbon Monoxide referenced to 3 % Oxygen. In the example we would be breaking the limit and corrective action should be taken to reduce the level of CO.

Oxygen referencing prevents false readings being submitted, e.g. allowing more air into the boiler will increase the oxygen level in the flue and dilute any toxic gas reading. Oxygen referencing gives readings as if they were undiluted.

Oxygen referencing is also referred to as :-

- Normalising
- Diluted and Undiluted readings
- 'Air Free' measurements when referenced to zero % oxygen.

Converting ppm to mg/m<sup>3</sup>

To convert Carbon Monoxide to mg/m<sup>3</sup> = CO ppm x 1.25

**NOTE!** Viewing stored readings uses the current value for the oxygen reference rather than the stored value.

## **D. ELECTROMAGNETIC COMPATIBILITY (EMC) STATEMENT**

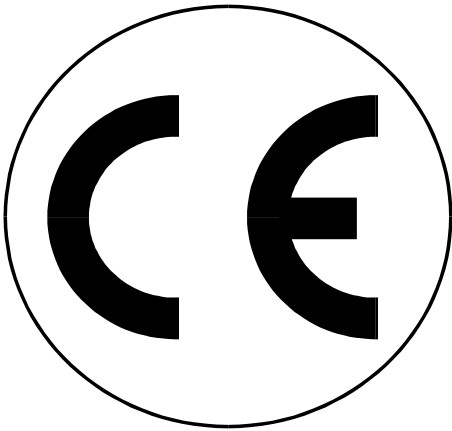

This product has been tested for compliance with the following generic standards:

EN 61000-6-3

EN 61000-6-1

and is certified to be compliant

Specification EC/EMC/KI/KANE 400 details the specific test configuration, performance and conditions of use.

### **Electromagnetic Compatibility**

The European Council Directive 89/336/EEC requires that electronic equipment does not generate electromagnetic disturbances that exceed defined levels and has an adequate level of immunity to enable it to be operated as intended. The specific standards applicable to this product are detailed in the appendices.

Since there are many electrical products in use that pre-date this Directive and may emit electromagnetic radiation in excess of the standards defined in the Directive there may be occasions where it would be appropriate to check the analyser before use. The following procedure should be adopted:

- Go through the normal start up sequence in the location where the equipment is to be used.
- Switch on all localised electrical equipment that might be capable of causing interference.
- Check that all readings are as expected. (A level of disturbance in the readings is acceptable).
- If not, adjust the position of the instrument to minimise interference or switch off, if possible, the offending equipment for the duration of the test.

At the time of writing this manual (January 2001) Kane International Ltd is not aware of any field based situation where such interference has ever occurred and this advice is only given to satisfy the requirements of the Directive.

## **E. PROTECTION AGAINST ELECTRIC SHOCK**

(in accordance with EN61010 – 1 : 1993)

This instrument is designated as Class III equipment and should only be connected to SELV circuits. The battery charger is designated as:

Class II equipment

Installation category II

Pollution degree 2

Indoor use only

Altitude to 2000m

Ambient temperature 0°C-40°C

Maximum relative humidity 80% for temperatures up to 31°C decreasing linearly to 50%RH at 40°C

Mains supply fluctuations not to exceed 10% of the nominal voltage

**Please Note:      Batteries used in this instrument should be disposed of in accordance with current legislation and local guidelines.**