

THIS DOCUMENT HAS BEEN PROVIDED BY

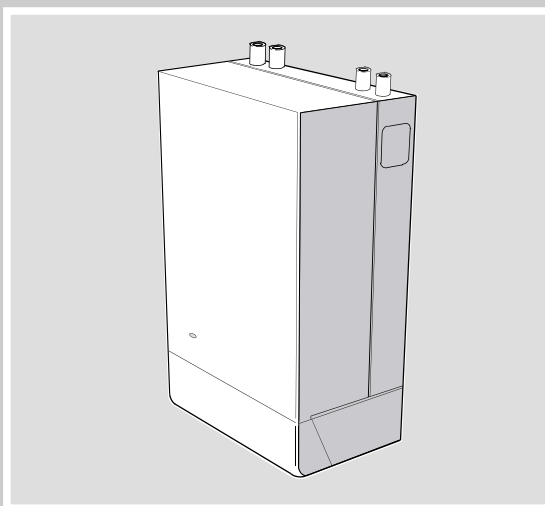

PLEASE VISIT WWW.HEATINGSPPARES247.COM FOR FURTHER INFORMATION AND GENUINE PARTS & SPARES AT LOW PRICES

USERS GUIDE



British/Scottish Gas RD1

the wall hung boiler

330 - 3100 RD1

Wall hung, gas fired
fanned flue boiler

British Gas 
Scottish Gas 

British Gas:

(Any internal reference to British Gas applies equally to Scottish Gas)

The British Gas RD1 is a range of cast iron wall mounted fanned flue gas central heating boilers. A complete range of natural gas models is available.

The ideal replacement boiler...

Easy to install, easy to operate and easy to service. The British Gas RD1 really is the ultimate replacement wall mounted range - you can depend on it.

Proven reliability...

Proven cast iron heat exchanger engineered and refined to be the most dependable wall mounted boiler ensuring totally calm operation and quiet running, whatever the system demands.

Complete range...

There are 7 models in the range. All models include a Downward Routing Pipe Kit and an overheat thermostat.

Full system suitability...

Most models are suitable for connection to pumped open vent central heating systems, pumped central heating combined with pumped or gravity indirect domestic hot water supply systems (note that the 100 model is not suitable for gravity installations).

They can also be used on sealed water systems.

Free Three Star Service Cover:

In addition to the guarantee, we will provide absolutely free a British Gas Services Three Star Service Cover agreement to cover your complete new system during the first year. The benefits of this cover include priority attention and a 24 hours a day 365 day a year helpline. Full details of the terms and conditions for Three Star Cover schemes are available separately on request.

British Gas RD1 (Natural Gas Models Only)

330	RD1	G.C. No. 41 392 13
340	RD1	G.C. No. 41 392 16
350	RD1	G.C. No. 41 392 17
360	RD1	G.C. No. 41 392 20
370	RD1	G.C. No. 41 392 21
380	RD1	G.C. No. 41 392 24
3 100	RD1	G.C. No. 41 392 25

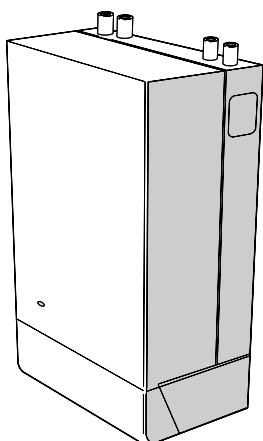

Introduction

It is essential that the instructions in this booklet are strictly followed, for safe and economic operation of the boiler.

Current Gas Safety (Installation & Use) Regulations or the rules in force.

In your own interest, and that of safety, it is the law that this boiler must be installed by a registered installer, in accordance with all national and local regulations.

Electricity Supply

This appliance must be efficiently earthed.

Supply: 230 V ~ 50 Hz. The fusing should be 3A.

Connection must be made in a way that allows complete isolation of the electrical supply such as a double pole switch having a 3mm (1/8") contact separation in both poles, or a plug and socket, serving only the boiler and system controls. The means of isolation must be accessible to the user after installation.

All CORGI Registered Installers carry a CORGI ID card, and have a registration number. Both should be recorded in your **Benchmark** Log Book. You can check your installer by calling CORGI direct on 0156 372 300.

THE LOG BOOK SHOULD BE COMPLETED AFTER EACH SERVICE AND KEPT WITH THESE INSTRUCTIONS



Remote appliance diagnostic system

This appliance is capable of automatically communicating operational data to a central computer processing system via the house ring main and telephone line, known as 'Remote Appliance Diagnostic System' (RADS). The information is transmitted in the early hours of the morning once every 30 days, or immediately if the boiler develops a fault. If an attempt is made to use the telephone during the transmission, some interference will be heard. In this event replace the receiver and try again after 30 seconds.

Important points

- This appliance must not be operated without the casing correctly fitted and forming an adequate seal.
- If the boiler is installed in a compartment then the compartment MUST NOT be used for storage purposes.
- The ventilation provided for the boiler during installation MUST NOT be blocked, and a check should be made periodically that the ventilation areas are free from any obstruction.
- If it is known or suspected that a fault exists on the boiler then it MUST NOT be used until the fault has been corrected by a CORGI registered installer.
- Flammable materials must not be placed in close proximity to the appliance. Materials giving off flammable vapours must not be stored in the same room as the appliance.
- Where the boiler is fitted with a Vertex flue system with a draught diverter in the loft, the loft MUST NOT be used as a dwelling area.
- Under NO circumstances should any of the sealed components on this appliance be used incorrectly or tampered with.

In cases of repeated or continuous shutdown a CORGI registered installer should be called to investigate and rectify the condition causing this and carry out an operational test after each intervention on the device. Only the manufacturer's original parts should be used for replacement.

Minimum clearances

A clearance of 533mm (21") MUST be available at the front of the boiler for servicing.

The minimum clearances given below MUST be complied with in order to maintain the safe running of the boiler. Refer to Table 1.

To light the boiler. Refer to Frame 1

- CHECK THAT THE ELECTRICITY SUPPLY TO THE BOILER IS OFF.
- Open the controls access door by hinging downwards.
- Ensure that the gas service cock (D) is OPEN.
- Press the overheat reset button (E), located as shown in Frame 1.
- Ensure that the thermostat on/off knob (B) is in the OFF position.
- Switch ON the electricity supply to the boiler. Check that all external controls, e.g. programmer, room thermostat etc., are ON.
- Set the boiler thermostat On/Off knob (B) to position 6. After about 25 seconds the boiler will light automatically - this can be viewed through the sight glass (A). Set the boiler thermostat to the desired position.
- Close the controls access door.

Note.

If the boiler fails to light after 5 attempts press the reset switch (C) and the ignition sequence will be repeated. If the boiler still fails to light consult a CORGI registered installer.

In winter conditions, i.e. central heating and domestic hot water, the thermostat should be set at position 5 or 6. For summer conditions, i.e. domestic hot water only, the thermostat should be set at position 3. These settings, however, are offered for general guidance only and other settings may be found preferable, dependent upon the type of system installed or as recommended by the installer.

1 BOILER CONTROLS

Table 1

Above the boiler	100 mm	(4")
At each side of the boiler	5 mm	(1/4")
Underneath the boiler	100 mm	(4")
In front of the boiler	75 mm	(3 ")

View inside boiler controls area

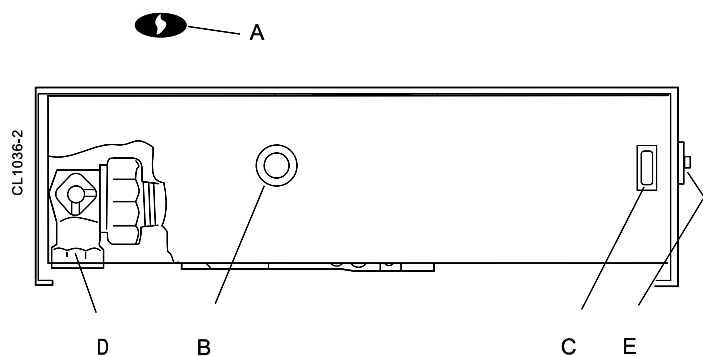

LEGEND

- A. Sightglass.
- B. Thermostat On/Off knob.
- C. Boiler reset switch.
- D. Gas service cock (shown in the OPEN position).
- E. Overheat thermostat reset button.

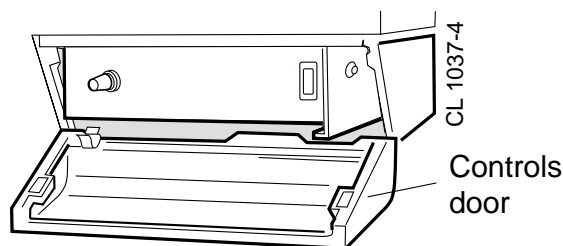

CAUTION. To avoid the possibility of injury during the installation, servicing or cleaning of this appliance care should be taken when handling edges of sheet steel components

Approximate flow temperatures for the boiler thermostat settings are:

Knob Setting	Flow Temperature	
	°C	°F
1	54	130
2	60	140
3	66	150
4	71	160
5	77	170
6	82	180

Control of water temperature

1. Adjust the boiler thermostat (B) to give the required temperature for central heating.
2. The boiler thermostat automatically switches the main burner OFF and ON to maintain the selected temperature.

To shut down the boiler

1. **For short periods**
Set the boiler On/Off knob (B) to OFF. When heating is again required, turn the knob to the desired position.
2. **For longer periods**
Set the boiler On/Off knob (B) to OFF. Switch OFF the electricity supply.

To relight the boiler

Repeat the procedure 1 - 8, detailed in 'To light the boiler'.

Frost protection

If no frost protection is provided and frost is likely during a short absence from home, leave the heating controls at a reduced temperature setting. For longer periods, the entire system should be drained - including the domestic water supply. If the system includes a frost thermostat then, during cold weather, the boiler

should be turned OFF at the time switch(es) ONLY. The mains supply should be left switched ON, with the boiler thermostat left in the normal running position.

Boiler Overheat Thermostat

The boiler is fitted with a safety 'cutout' thermostat. This will shut down the boiler in the event of overheating. Should this occur allow the boiler to cool, press the reset button (E) then relight as detailed in steps 1-8 in 'To light the boiler'. *If the cutout condition still persists turn off the boiler and consult a CORGI registered installer.*

Loss of system water pressure

Boilers fitted with Sealed System Units only

If the red arrow on the unit pressure gauge is set above zero and the system pressure is seen to fall below this value over a period of time then a water leak is indicated. In this event a CORGI registered installer should be consulted.

DO NOT OPERATE THE BOILER IF THE PRESSURE HAS REDUCED TO ZERO FROM THE ORIGINAL SETTING.

Escape of gas

Should a gas leak be suspected, contact your local gas supplier without delay.

Do NOT search for gas leaks with a naked flame.

Cleaning

For normal cleaning simply dust with a dry cloth. To remove stubborn marks and stains, wipe with a damp cloth and finish off with a dry cloth.

Do NOT use abrasive cleaning materials.

Maintenance

The appliance should be serviced at least once a year by a CORGI registered installer.

This boiler is exclusively manufactured for British Gas by Ideal Boilers



The code of practice for the installation, commissioning & servicing of central heating systems

British Gas Services Limited is a member of the Benchmark initiative and fully supports the aims of the programme. Benchmark has been introduced to improve the standards of installation and commissioning of central heating systems in the UK and to encourage the regular servicing of all central heating systems to ensure safety and efficiency.



CERTIFIED PRODUCT
Manufactured under a BS EN ISO 9001:1994 Quality System accepted by BSI.



British Gas Services Limited. Registered in England, No. 3141243. Registered Office: Millstream, Maidenhead Road, Windsor, Berkshire SL4 5GD. British Gas Services Ltd. has made every effort to ensure that the information contained in this leaflet is accurate. However, not all the information is within the control of British Gas Services Ltd., and it may have changed since publication. British Gas Services Ltd. does not accept any liability for changes which occur after publication. No guarantee takes away any rights you may have at law. Calls to this number may be monitored to maintain a high level of service and for training purposes.

British Gas pursues a policy of continuing improvement in the design and performance of its products. The right is therefore reserved to vary specification without notice.

September 2001 UIN 157 023 A01



If you would like this leaflet in an alternative format such as large print, Braille or audio cassette please call us on 0845 7 754 754



If you have impaired hearing and use a text phone please call us on 0845 6 040 345



Priority Helpline 08459 500 400