

IDEAL ELAN 2

RS 230, RS 240, RS 250, RS 260 & RS 275

Wall Mounted, Balanced Flue Gas Boilers.

Installation & Servicing.

CAUTION: To avoid the possibility of injury during the installation, servicing or cleaning of this appliance, care should be taken when handling edges of sheet steel components.

IMPORTANT: The appliances are for use with **NATURAL GAS ONLY.**

Ideal Elan 2	G.C. Number
RS 230	41 429 51
RS 240	41 429 52
RS 250	41 429 53
RS 260	41 429 54
RS 275	41 429 55

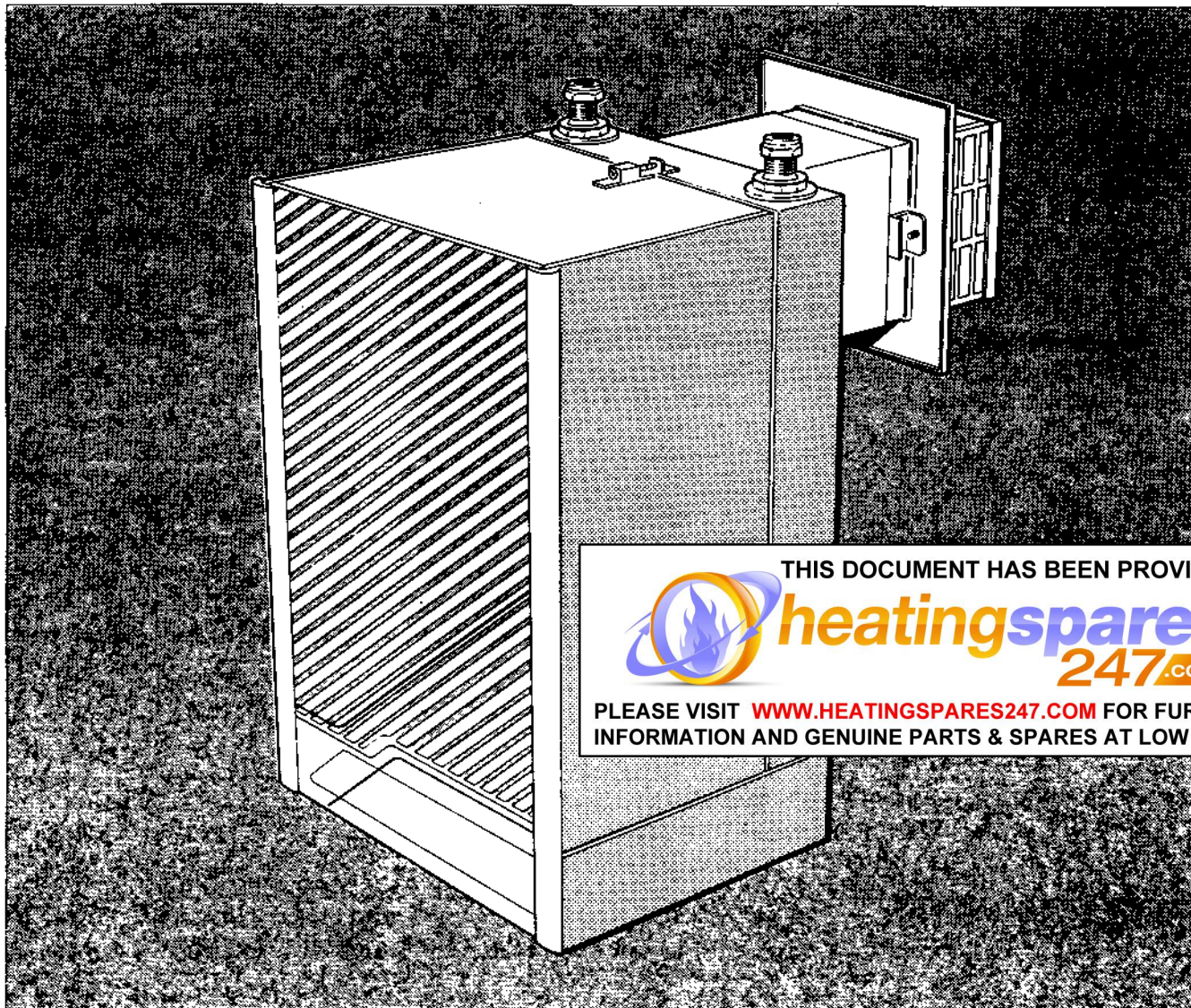

THIS DOCUMENT HAS BEEN PROVIDED BY
 **heating spares**
247.com
PLEASE VISIT WWW.HEATINGSPPARES247.COM FOR FURTHER
INFORMATION AND GENUINE PARTS & SPARES AT LOW PRICES

NOTE TO THE INSTALLER: Leave these instructions adjacent to the gas meter or with the user



Table 1- GENERAL DATA

Boiler Size		RS 230	RS 240	RS 250	RS 260	RS 275
Main burner bar		Aeromatic AC 19/123 278	Aeromatic AC 19/123 275	Aeromatic AC 19/123 276		Aeromatic AC 19/123 277
Gas control		HONEYWELL V 4700 E 1072, 240 V				
Burner Injector	BRAY	Cat. 16 Size 750	Cat. 16 Size 1100	Cat. 16 Size 1400	Cat. 16 Size 1700	Cat. 10 Size 2200
Pilot injector		HONEYWELL 459100421-001 (STAMPED) 38/36A				
Gas supply connection (in. BSP)		Rc 1/2 (1/2)				
Flow connection	Compression fittings	22 mm O.D.				28 mm O.D.
Return connection	Compression fittings	22 mm O.D.				28 mm O.D.
Maximum static water head	m (ft.)	30.5 (100)				
Minimum static water head	m (ft.)	0.45 (1.5)				
Electrical supply		240 V ~ 50 Hz				
External fuse rating		3 A				
Water content	litre (gal.)	1.0 (0.22)	1.2 (0.27)		1.5 (0.33)	
Dry weight	kg (lb)	18.6 (40.9)	20.6 (45.3)		26.9 (59.3)	
Maximum installation weight	kg (lb)	13.3 (29.3)	15.3 (33.7)		19.1 (42.1)	
Boiler size	Height	mm (in.)	600 (24.0)			
	Width	mm (in.)	380 (15.0)			465 (18.0)
	Depth	mm (in.)	300 (12)			

Table 2- PERFORMANCE DATA

Boiler Size		RS 230	RS 240	RS 250	RS 260	RS 275	
Boiler input To obtain gas consumption (a) For l/s; divide heat input (kW) by C.V. of the gas (MJ/m ³). (b) For ft ³ /h; divide heat input (Btu/h) by C.V. of the gas (Btu/ft ³). Heat inputs are pre-set to the highest nominal rating.	MINIMUM	kW (Btu/h)	5.8 (19 700)	11.1 (37 700)	14.7 (50 000)	18.6 (63 300)	22.3 (76 000)
	Gas consumption	l/s (ft ³ /h)	0.15 (19.4)	0.29 (36.3)	0.38 (48.2)	0.48 (61.0)	0.58 (73.2)
	MID	kW (Btu/h)	8.5 (28 900)	12.8 (43 800)	16.5 (56 300)	20.3 (69 200)	24.9 (84 900)
	Gas consumption	l/s (ft ³ /h)	0.22 (27.8)	0.33 (42.2)	0.43 (54.2)	0.52 (66.7)	0.64 (81.8)
	MAXIMUM	kW (Btu/h)	11.0 (37 500)	14.7 (50 000)	18.3 (62 500)	22.0 (75 000)	27.5 (93 800)
	Gas Consumption	l/s (ft ³ /h)	0.28 (36.1)	0.38 (48.2)	0.47 (60.2)	0.57 (72.3)	0.71 (90.4)
Boiler output	MINIMUM	kW (Btu/h)	4.4 (15 000)	8.8 (30 000)	11.7 (40 000)	14.7 (50 000)	17.6 (60 000)
	MID	kW (Btu/h)	6.6 (22 500)	10.3 (35 000)	13.2 (45 000)	16.1 (55 000)	19.8 (67 500)
	MAXIMUM	kW (Btu/h)	8.8 (30 000)	11.7 (40 000)	14.7 (50 000)	17.6 (60 000)	22.0 (75 000)
Burner setting pressure (HOT)	MINIMUM	mbar (in.w.g.)	5.2 (2.1)	8.3 (3.3)	8.8 (3.5)	9.7 (3.9)	9.6 (3.8)
	MID	mbar (in.w.g.)	10.2 (4.1)	10.8 (4.3)	10.9 (4.3)	11.0 (4.4)	12.0 (4.8)
	MAXIMUM	mbar (in.w.g.)	16.4 (6.5)	14.0 (5.6)	13.2 (5.3)	13.0 (5.2)	14.7 (5.9)

INTRODUCTION

The **Ideal Elan 2** RS 230, RS 240, RS 250, RS 260 and RS 275 are wall mounted, lightweight, natural draught, balanced flue gas boilers.

They are range rated to provide central heating outputs of 4.4kW (15,000 Btu/h) to 22.0 kW (75 000 Btu/h).

The boiler casing is of white enamelled mild steel, with a fascia of satinised white glass. The controls pod, also of white enamelled mild steel, has fixed sides and a removable bottom panel.

The glass fascia slides upwards to reveal the boiler thermostat (in the control box mounted on the gas valve) and the programmer (if fitted).

A **Programmer Kit**, which fits neatly within the casing, is available as an optional extra. Separate fitting instructions are included with the kit.

The boilers are suitable for connection to fully pumped, open vented or sealed water systems. Adequate arrangements for completely draining the system by provision of drain cocks **MUST** be provided in the installation pipework.

The boilers are suitable for the following wall thicknesses;

- 114 mm (4 1/2 in.) to 203 mm (8 in.),
- 229 mm (9 in.) to 203 mm (12 1/2 in.) and
- 330 mm (13 in.) to 394 mm (15 1/2 in.),

Wall thicknesses outside of these sizes cannot be accommodated.

Gas Safety (Installation and Use) Regulations, 1984

It is the law that all gas appliances are installed by competent persons (e.g. CORGI, identified by ) in accordance with the above Regulations. Failure to install appliances correctly could lead to prosecution. It is in your own interest, and that of safety, to ensure that the law is complied with.

The installation of the boiler **MUST** also be in accordance with the current I.E.E. Wiring Regulations, the Local Building Regulations, Building Standards (Scotland), the bye-laws of the Local Water Undertaking and any relevant requirements of the Local Authority.

Detailed recommendations are contained in the following British Standard Codes of Practice.

BS. 6891	Low pressure installation pipes.
BS. 6798	Installation of gas fired hot water boilers of rated input not exceeding 60 kW.
BS. 5449	Forced circulation hot water systems.
BS. 5546	Installation of gas hot water supplies for domestic purposes (2nd Family gases).
BS. 5440:1	Flues (for gas appliances of rated input not exceeding 60 kW).
BS. 5440:2	Ventilation (for gas appliances of rated input not exceeding 60 kW).

Manufacturer's notes must not be taken in any way as overriding statutory obligations.

IMPORTANT. These appliances are certificated by the British Standards Institution for safety and performance. It is, therefore, important that no external control devices, e.g. flue dampers, economisers, etc., are directly connected to these appliances - unless covered in these 'Installation and Servicing Instructions' or otherwise recommended by Caradon Heating Ltd. in writing.

INTRODUCTION - GAS SUPPLY

Any direct connection of a control device not approved by Caradon Heating Ltd. could invalidate the B.S.I. certification and the normal appliance warranty. It could also infringe the Gas Safety Regulations and the above regulations.

LOCATION OF BOILER

The boiler **MUST** be installed on a flat and vertical external wall, capable of adequately supporting the weight of the boiler and any ancillary equipment.

The boiler may be fitted on a combustible wall and insulation between the wall and boiler is not necessary - unless required by the Local Authority. **THE BOILER IS NOT SUITABLE FOR EXTERNAL INSTALLATION.**

IMPORTANT NOTICE. If the boiler is to be fitted in a timber framed building it should be fitted in accordance with the British Gas publication 'Guide for Gas Installations in Timber Frame Housing', Reference DM2. If in doubt advice must be sought from the Local Gas Region of British Gas.

The boiler may be installed in any room or internal space, although particular attention is drawn to the requirements of the current I.E.E. Wiring Regulations and, in Scotland, the electrical provisions of the Building Regulations applicable in Scotland with respect to the installation of the boiler in a room or internal space containing a bath or shower.

Where a room-sealed appliance is installed in a room containing a bath or shower then the appliance and any electrical switch or appliance control utilising mains electricity should be so situated that it cannot be touched by a person using the bath or shower.

Where installation will be in an unusual location, special procedures may be necessary and BS. 6798 gives detailed guidance on this aspect.

A compartment used to enclose the boiler **MUST** be designed and constructed specially for this purpose. An existing cupboard or compartment may be used, provided it is modified for the purpose. Details of essential features of cupboard / compartment design, including airing cupboard installation are given in BS. 6798.

In siting the boiler, the following limitations **MUST** be observed:

1. The position selected for installation **MUST** allow adequate space for servicing in front of the boiler and for air circulation around the boiler. For the minimum clearances required for safety and subsequent service, see the Wall Mounting Template and Frame 4. In addition sufficient space may be required to allow lifting access onto the wall mounting plate.
2. This position **MUST** also permit the provision of a satisfactory flue termination.

GAS SUPPLY

The Local Gas Region should be consulted at the installation planning stage in order to establish the availability of an adequate supply gas.

An existing service pipe must **NOT** be used without prior consultation with the Local Gas Region.

A gas meter can only be connected by the Local Gas Region, or by a local Gas Region Contractor. An existing meter should be checked, preferably by the Gas Region, to ensure the meter is adequate to deal with the rate of gas supply required.

Installation pipes should be fitted in accordance with BS 6891.

Pipework from the meter to the boiler MUST be of an adequate size. Do NOT use pipes of smaller size than the boiler inlet gas connection.

The complete installation MUST be tested for gas soundness and purged as described in the above Code.

FLUE INSTALLATION

The flue must be installed in accordance with the recommendations of BS. 5440:1.

The following notes are intended for general guidance.

1. The boiler MUST be installed so that the terminal is exposed to external air.
2. It is important that the position of the terminal allows the free passage of air across it at all times.
3. Minimum acceptable spacings from the terminal to obstructions & ventilation openings are specified in Table 3.
4. Where the lowest part of the terminal is fitted less than 2 m (6.6 ft.) above a balcony, above ground or above a flat roof to which people have access then the terminal MUST be protected by a purpose designed guard.

Terminal guards are available from:

Quinnel, Barret & Quinnel Ltd.,
884 Old Kent Road, London, SE 15
RS 230 to RS 260 - Model P6.
RS 275 - Model M4

and from,
Tower Flue Components Ltd.,
Vale Rise, Tonbridge, Kent, TN9 1TB
RS 230 to RS 260 - Model C.
RS 275 - Model F.

Ensure that the guard is fitted centrally.

5. Where the terminal is fitted within 850 mm (34 in.) of a plastic or painted gutter or 450 mm (18 in.) of painted eaves then an aluminium shield at least 750 mm (30 in.) long should be fitted to the underside of the gutter or painted surface.
6. The air inlet / products outlet duct and the terminal of the boiler MUST NOT be closer than 25 mm (1 in.) to combustible material. Detailed recommendations on the protection of combustible material are given in BS. 5440:1 1990.

IMPORTANT. It is absolutely ESSENTIAL to ensure, in practice, that products of combustion discharging from the terminal cannot re-enter the building or any other adjacent building through ventilators, windows, doors, other sources of natural air infiltration, or forced ventilation/ air conditioning.

If this should occur, the appliance MUST be turned OFF immediately and the Local Gas Region consulted.

TERMINAL

The terminal assembly can be adapted to accommodate various wall thicknesses, refer to Frame 1 'Unpacking'.

AIR SUPPLY

Detailed recommendations for air supply are given in BS. 5440:2. The following notes are for general guidance:

1. It is NOT necessary to have a purpose provided air vent in the room or internal space in which the boiler is installed.
2. If the boiler is to be installed in a cupboard or

cooling purposes) in the cupboard/ compartment, at both high and low levels. The air vents must either communicate with room/internal space, or be direct to outside air. The minimum effective areas of the permanent air vents, required in the cupboard/ compartment, are specified as follows and are related to maximum rated heat input.

3. Both air vents MUST communicate with the same room or internal space, or MUST be on the same wall to outside air.
4. In siting the air vents care must be taken to avoid the freezing of pipework.

Refer to Tables 4 - 8 for details of air vent position and sizing.

Table 3 - BALANCED FLUE TERMINAL POSITION

Terminal Position	Minimum Spacing
1. Directly below an opening window, air vent or other ventilation opening.	300 mm (12 in.)
2. Below guttering, drain pipes or soil pipes.	300 mm (12 in.)
3. Below eaves.	300 mm (12 in.)
4. Below balconies or a car port roof.	600 mm (24 in.)
5. From vertical drain pipes or soil pipes.	75 mm (3 in.)
6. From internal or external corners.	600 mm (24 in.)
7. Above adjacent ground, roof or balcony level.	300 mm (12 in.)
8. From a surface facing the terminal.	600 mm (24 in.)
9. From a terminal facing a terminal.	600 mm (24 in.)
10. From an opening in a car port (eg. door or window) into dwelling.	1200 mm (48 in.)
11. Vertically from a terminal on the same wall.	1500 mm (60 in.)
12. Horizontally from a terminal on the wall.	300 mm (12 in.)

Table 4 - RS 230 AIR SUPPLY

Position of air vent	Air from room/ internal space	Air direct from outside
HIGH LEVEL cm ² (in ²)	100 (16)	50 (8)
LOW LEVEL cm ² (in ²)	100 (16)	50 (8)

Table 5 - RS 240 AIR SUPPLY

Position of air vent	Air from room/ internal space	Air direct from outside
HIGH LEVEL cm ² (in ²)	133 (21)	67 (11)
LOW LEVEL cm ² (in ²)	133 (21)	67 (11)

Table 6 - RS 250 AIR SUPPLY

Position of air vent	Air from room/ internal space	Air direct from outside
HIGH LEVEL cm ² (in ²)	165 (26)	88 (13)
LOW LEVEL cm ² (in ²)	165 (26)	88 (13)

Table 7 - RS 260 AIR SUPPLY

Position of air vent	Air from room/ internal space	Air direct from outside
HIGH LEVEL cm ² (in ²)	200 (31)	100 (16)
LOW LEVEL cm ² (in ²)	200 (31)	100 (16)

Table 8 - RS 275 AIR SUPPLY

Position of air vent	Air from room/ internal space	Air direct from outside
HIGH LEVEL cm ² (in ²)	248 (39)	124 (20)
LOW LEVEL cm ² (in ²)	248 (39)	124 (20)

Table 9 - WATER FLOW RATE AND PRESSURE LOSS

Boiler Size	RS 230	RS 240	RS 250	RS 260	RS 275
Boiler output kW	8.8	11.7	14.7	17.6	22.0
Btu/h	30 000	40 000	50 000	60 000	75 000
Water flow rate l/min	11.4	15.2	19.0	22.8	28.5
gal/h	150	200	250	300	375
Pressure loss mbar	27	45	70	102	80
in.w.g.	11	18	28	41	32

WATER CIRCULATION SYSTEM

The boiler must NOT be used for direct hot water supply.

The boiler is suitable for connection to fully pumped open vented or sealed water central heating systems or central heating combined with indirect domestic hot water systems.

The central heating system should be in accordance with BS. 6798 and in addition, for Smallbore and Microbore systems, BS. 5449

The domestic hot water system, if applicable, should be in accordance with relevant recommendations to BS. 5546.

Copper tubing to BS. 2871: 1 is recommended for water carrying pipework.

The hot water storage cylinder MUST be of the indirect type and should be, preferably, manufactured of copper.

Single-feed, indirect cylinders are not recommended and MUST NOT be used on sealed systems.

The hot water cylinder and ancillary pipework not forming part of the useful heating surface should be lagged to prevent heat loss and any possible freezing, particularly where pipes run through roof spaces and ventilated under floor spaces.

Draining taps MUST be located in accessible positions, which permit the draining of the whole system, including the boiler and hot water storage vessel.

Draining taps should be at least 1/2 in. nominal size and be in accordance with BS. 2879.

The hydraulic resistances of the boilers, at MAXIMUM OUTPUT with an 11°C (20°F) temperature differential, are shown in Table 9.

ELECTRICAL SUPPLY

Wiring external to the appliance MUST be in accordance with the current I.E.E. Wiring Regulations and any Local Regulations which apply.

The boiler is supplied for 240 V ~ 50 Hz

Single Phase

Fuse Rating is 3 A

The method of connection to the mains electricity supply MUST facilitate complete electrical isolation of the boiler, preferably by the use of a fused, unswitched three pin plug and a shuttered socket outlet, both complying with the requirements of BS. 1363.

Alternatively, a fused double pole switch, having at least a 3 mm (1/8 in.) contact separation in both poles and servicing only the boiler, may be used.

The point of connection to the mains should be readily accessible and adjacent to the boiler, except that for bathroom installations, the point of connection to the mains MUST be situated outside of the bathroom.

Note. Where a room sealed appliance is installed in a room containing a bath or shower then the appliance and any electrical switch or appliance control utilising mains electricity should be so situated that it cannot be touched by a person using the bath or shower.

1 UNPACKING

The boiler is supplied fully assembled in one pack 'A', together with a Flue Pack (B, B1 or C) containing the flue terminal appropriate to the wall thickness. Optional extras, if ordered (Programmer Kit) are available in separate boxes. Unpack and check the contents.

PACK 'A' CONTENTS

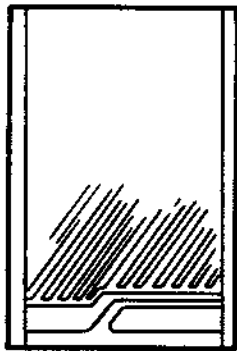

Complete boiler

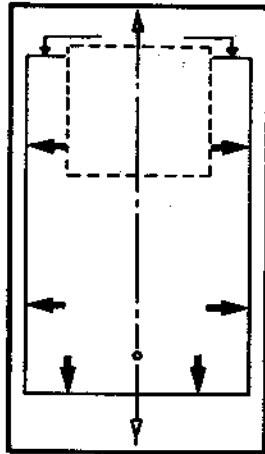

Wall mounting template

Also contained in Pack A; the Hardware pack, these Installation & Servicing instructions, and the User's Instructions.



Wall mounting plate

Hardware Pack

- No. 10 x 50 mm wood screws, 3 - off.
- Wall plug (TP2B), 6 - off.
- No. 14 x 50 mm wood screw, 3 - off
- Output setting indicator, 1 - off
- Back panel to wall sealing strip, 3 - off

FLUE PACKS

Note. All flue packs contain 2 sachets of sealant

PACK B. Contains a balanced flue terminal suitable for wall thicknesses from 229 mm (9 in.) to 318 mm (12 1/2).

PACK B1. Contains a balanced flue terminal suitable for wall thicknesses from 330 mm (13 in.) to 394 mm (15 1/2).

PACK C. Contains a balanced flue terminal suitable for wall thicknesses from 114 mm (4 1/2 in.) to 203 mm (8).

2 BOILER ASSEMBLY - Exploded View

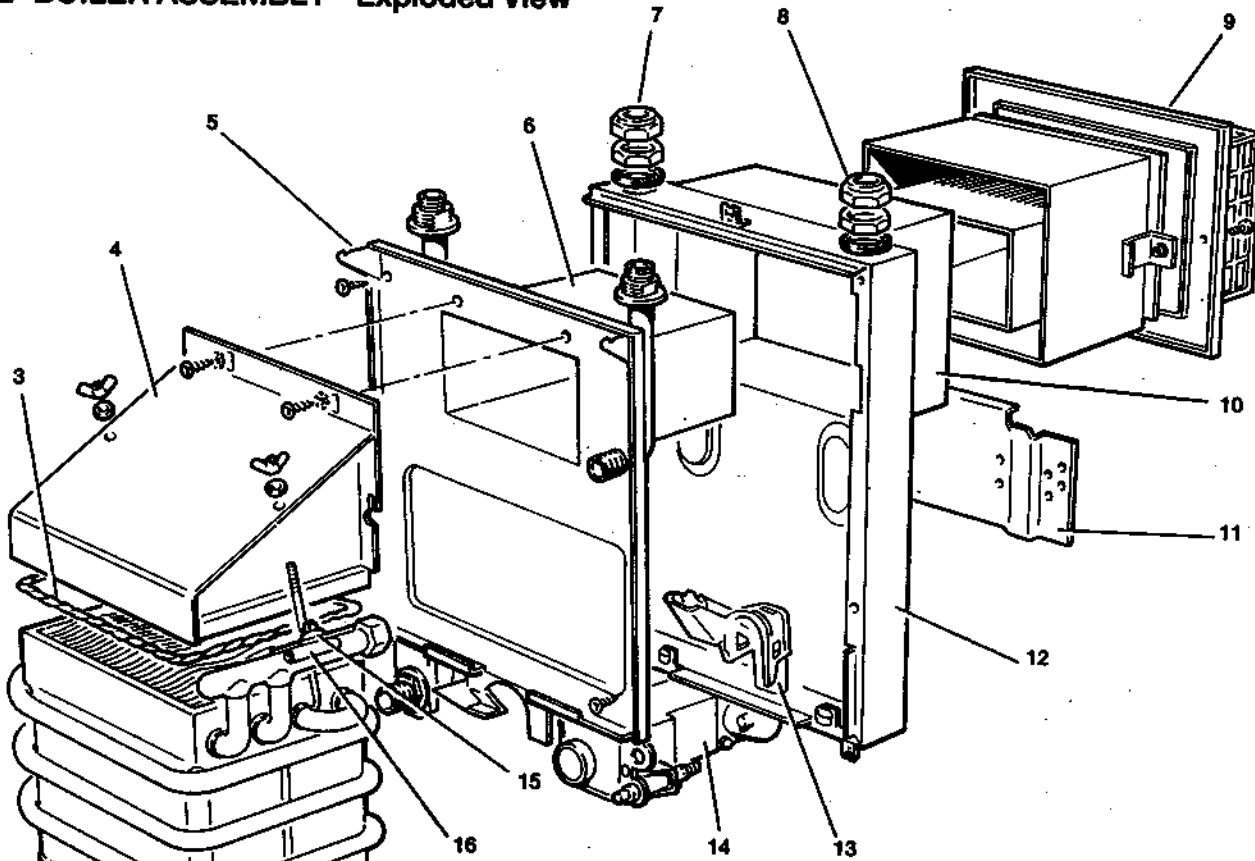

LEGEND

- | | | |
|---------------------------|------------------------------|---|
| 1. Main burner. | 7. Return connection. | 13. Air box & pilot assembly. |
| 2. Heat exchanger. | 8. Flow connection. | 14. Control box (mounted on gas control valve). |
| 3. Collector hood gasket. | 9. Terminal grille assembly. | 15. Overheat thermostat. |
| 4. Collector hood. | 10. Air duct. | 16. Control thermostat pocket. |
| 5. Interpanel. | 11. Wall mounting plate. | |
| 6. Flue duct. | 12. Back panel. | |

3 WALL MOUNTING AND WALL THICKNESS

IMPORTANT. The boiler **MUST** be installed in a vertical position.

1. The flue duct should be horizontal, but a slight downwards slope away from boiler is acceptable.
2. The wall must be of suitable load bearing capacity.
3. Use the jacking screw to align the boiler.

WALL THICKNESS Dimension 'X'	Flue Pack Required
114 to 203 mm (4 1/2 to 8 in.)	C
229 to 318 mm (9 to 12 1/2 in.)	B
330 to 394 mm (13 to 15 1/2 in.)	B1

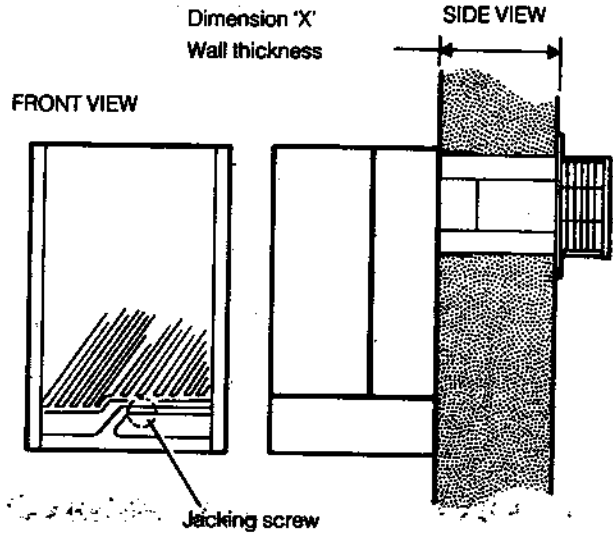

4 BOILER CLEARANCES

The following minimum clearances must be maintained for operation and servicing.

Additional space will be required for installation depending, upon site conditions

Boiler size	Width Dimension A	Depth	Height
RS 230 to RS 260	390 (16)	300 (12)	800 (32)
RS 275	475 (19)	300 (12)	800 (32)

In addition a minimum of 450 mm (18 in.) **MUST** be available at the front of the boiler for servicing.

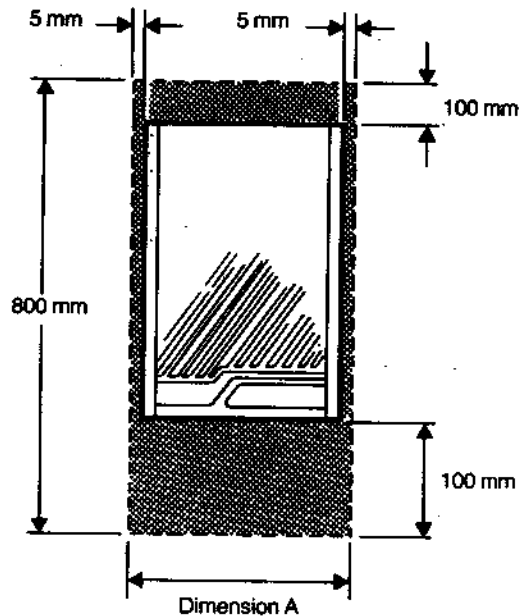

5 BOILER CASING REMOVAL

To install the boiler, the casing **MUST** be removed.

1. Release the top captive screw.
2. Slide the glass fascia upwards until it locates in the retaining catch.
3. Remove the two securing screws, slide the bottom panel forward slightly & then sideways to remove from the casing.
4. Release the 2 bottom captive screws and lift the casing off the boiler. Place the casing safely to one side, taking care not to damage the glass fascia panel. (Slide the glass panel down in the casing for safe keeping.)

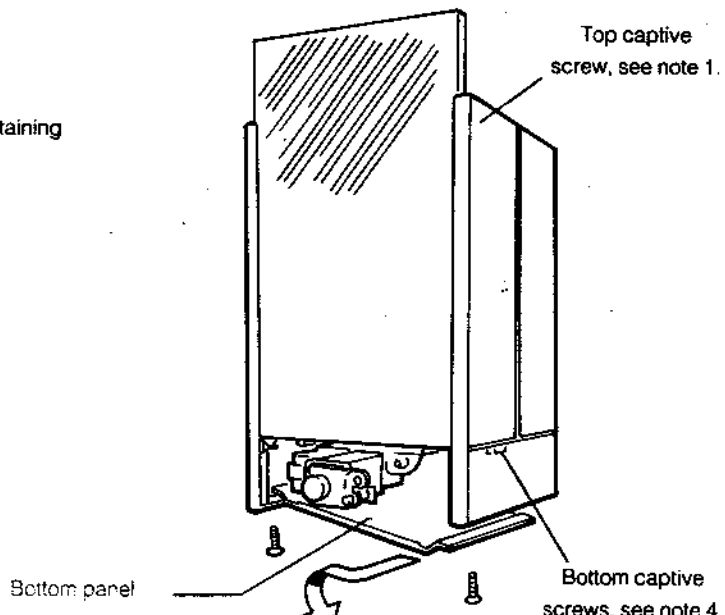

6 WALL MOUNTING TEMPLATE

1. Tape the template into the selected position. Ensure squareness by use of a plumbline - as shown.
2. Mark onto the wall the two mounting plate screw positions, the lower fixing screw position and the positions of the top cover plate screws.

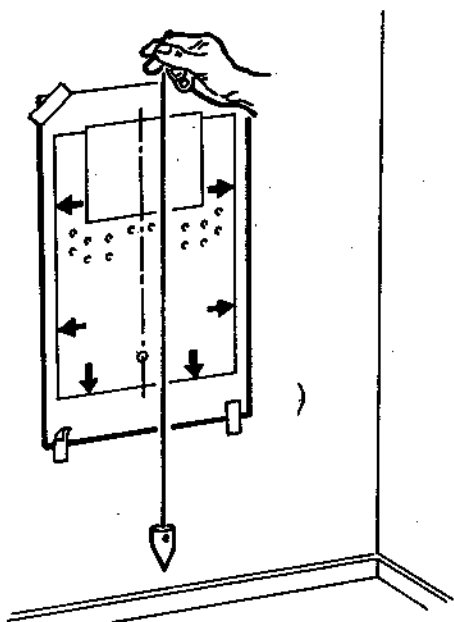

3. Mark onto the wall the position of the flue duct.
4. Remove the template from the wall.

7 PREPARING THE WALL

NOTE. THE WALL MUST BE OF A SUITABLE LOAD BEARING CAPACITY

1. Drill the three fixing holes and top cover plate screw holes with an 8 mm (5/16 in.) masonry drill and insert the plastic plugs provided.
2. Cut the appropriate hole in the wall for insertion of the terminal assembly. **Note.** The terminal **MUST** not come into contact with a combustible material such as that used in the non-standard construction of timber framework and plaster board etc.

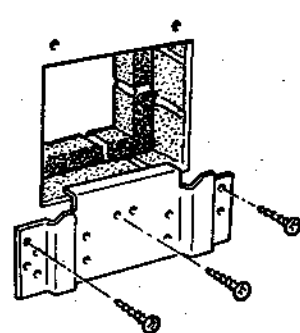

Wall mounting plate

Note. Check all hole positions before drilling.

3. Fix the mounting plate to the wall with the three No. 14 x 50 mm long screws provided.

8 PREPARING & MOUNTING THE BOILER

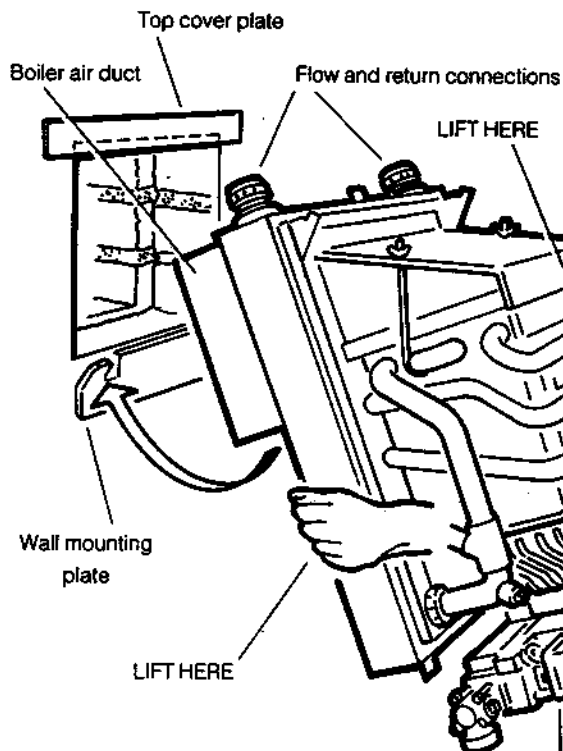

1. Carefully place the boiler on its side and stick the self adhesive sealing tape to the boiler back panel as shown.

REAR VIEW OF BOILER

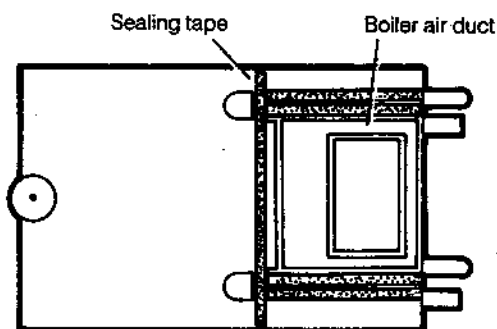

2. Remove the compression nuts and olives. If side access is less than 25 mm (1 in.), fit stub connections to the flow and return connections.
3. Lift the boiler onto the wall mounting plate, entering the projecting air duct into the opening cut into the wall & lowering the two slots in the boiler back panel onto the angled tabs on the top of the wall mounting plate. **DO NOT USE THE BURNER ASSEMBLY FOR LIFTING.**
4. Adjust the flue to its horizontal position by tilting the boiler forward at the bottom and then turning the jacking plate. Release and check the alignment with a spirit level.

5. Locate a No. 10 x 50 mm screw in the boiler lower fixing hole (on the jacking plate) and secure to the wall.
6. Fit the top cover plate in position above the boiler air duct

9 FITTING THE FLUE ASSEMBLY - Ideal Elan 2 RS 230, RS 240, RS 250 & RS 260 only

FLUE TERMINAL ASSEMBLY

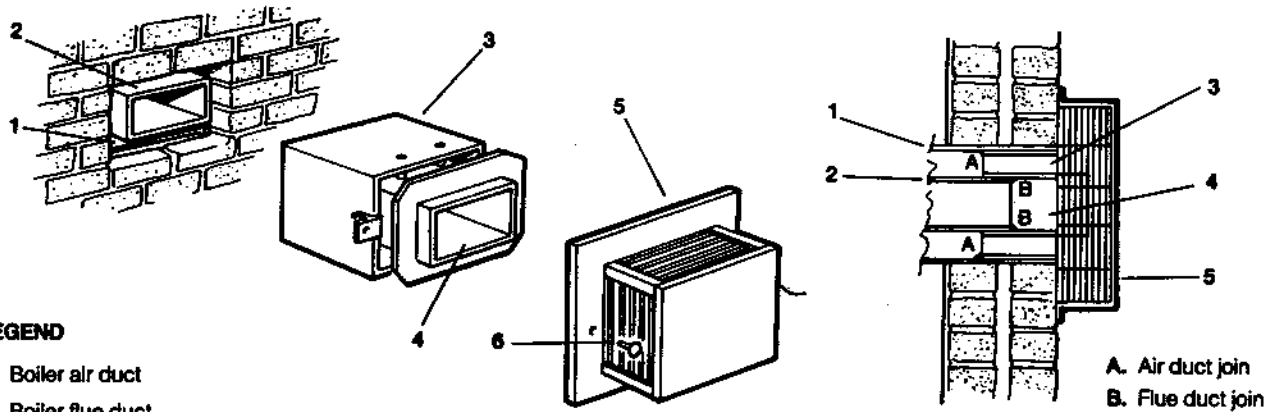

LEGEND

- 1. Boiler air duct
- 2. Boiler flue duct
- 3. Terminal air duct
- 4. Terminal flue duct
- 5. Terminal grille
- 6. Terminal grille securing screws

FLUE TERMINAL SHOWN IN POSITION

- A. Air duct join
- B. Flue duct join

1. Remove the two securing screws and separate the terminal grille from the terminal assembly.
2. Remove the four securing screws and separate the terminal flue duct from the terminal air duct.
3. From OUTSIDE of the building, pass the terminal air duct through the wall opening and slide it into the boiler air duct, locating it as shown.
4. Push the terminal air duct fully in - until the fixing brackets contact the wall face.
5. Make good between the wall and duct, from OUTSIDE of the building.
6. From OUTSIDE the building, seal the air duct join (A) with the sachet of sealant supplied.
7. From OUTSIDE of the building, pass the terminal flue duct through the wall opening and slide it into the boiler flue duct. Locate it as shown and fix in position with the screws previously removed.
8. From OUTSIDE of the building seal the flue duct join (B) with the sachet of sealant supplied.
9. Fasten the terminal grille to the duct assembly.

10 FITTING THE FLUE ASSEMBLY - Ideal Elan 2 RS 275 only

FLUE TERMINAL ASSEMBLY

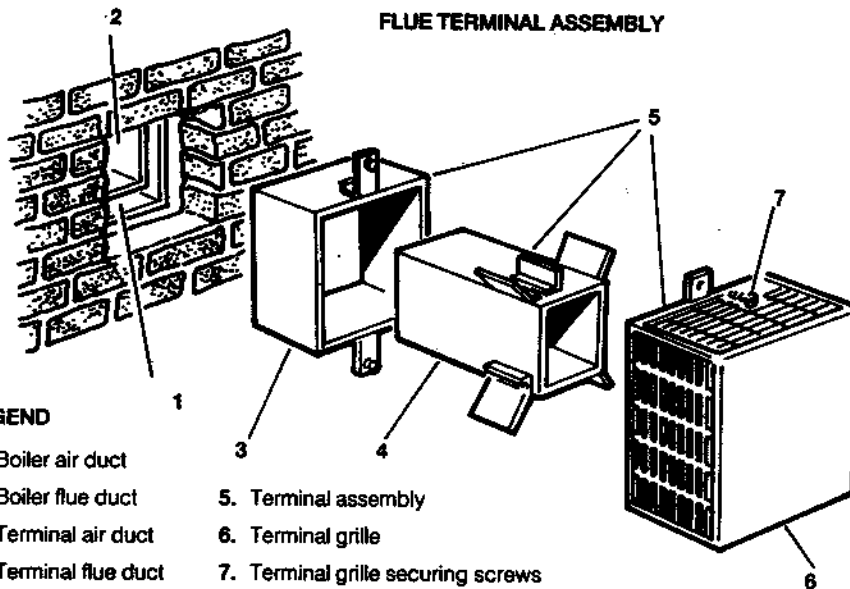

LEGEND

- 1. Boiler air duct
- 2. Boiler flue duct
- 3. Terminal air duct
- 4. Terminal flue duct
- 5. Terminal assembly
- 6. Terminal grille
- 7. Terminal grille securing screws

FLUE TERMINAL SHOWN IN POSITION

- A. Air duct join
- B. Flue duct join

1. Remove the two securing screws and separate the terminal air duct, flue duct and grille.
2. From OUTSIDE of the building, pass the terminal air duct through the wall opening and slide it into the boiler air duct, locating it as shown.
3. Push the terminal air duct fully in - until the fixing brackets contact the wall face.
4. Make good between the wall and duct, from OUTSIDE of the building.
5. From OUTSIDE the building seal the air duct join (A) with the sachet of sealant supplied.
6. From OUTSIDE of the building, pass the terminal flue duct through the wall opening and slide it into the boiler flue duct, locate it as shown.
7. Push the flue duct fully in, up to the locating stops.
8. From OUTSIDE of the building, seal the flue duct join (B) with the sachet of sealant supplied.
9. Fasten the terminal grille to the duct assembly.

11 GAS CONNECTION

1. A MINIMUM working gas pressure of 20 mbar (8 in.wg) MUST be available at the boiler inlet.
2. Extend a gas supply pipe NOT LESS THAN 15 mm O.D. to the boiler and connect to the gas service cock situated at the bottom left hand side of the boiler.
Note. If the pipe run from the meter to the boiler is greater than 3 m (10 ft.), it is recommended that 22 mm O.D. pipe is used.

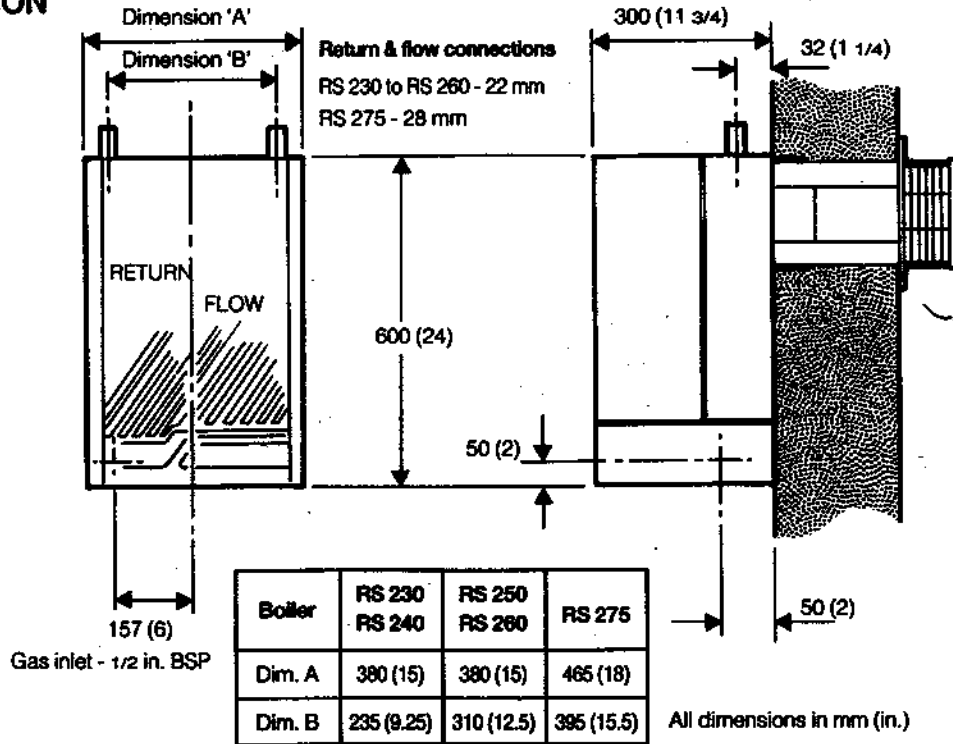

3. To facilitate connection, it is recommended that the gas service cock is not removed from the gas control valve. A 1/2 in. BSP x 15 mm connector prefitted with a short stub connection should be screwed into the cock using a suitable sealant. Ensure that the gas supply pipe does not foul the boiler casing when fitted.

IMPORTANT. The gas service cock contains a non-metallic seal, so must not be overheated when making capillary connections.

4. Test the gas installation for soundness and purge in accordance with BS. 6891.

12 WATER CONNECTIONS

1. Connect the system flow and return pipework to the two water connections at the top of the boiler.

Note. When the required output exceeds 16.1 kW (55 000 Btu/h) then 28 mm (1 in.) flow and return pipes should be used, both to and from the boiler. On the RS 260 boiler only, connect to the boiler in 22 mm (1/2 in.) pipe and increase to 28 mm (1 in.) as soon as is practical.

2. Ensure that all valves are open, fill and vent the system and check for water soundness.

Note. This appliance is NOT suitable for use with a direct hot water cylinder.

IDEAL ELAN NF RS 275 ONLY

When venting the heat exchanger using the manual airvent on the flow header, protect the electrical controls with a waterproof sheet or similar.

13 OPEN VENT SYSTEM REQUIREMENTS

The system should be vented directly off the boiler FLOW pipe, as close to the boiler as possible. The cold feed entry should be inverted and MUST be positioned between the pump and the vent, and not more than 150 mm (6 in.) away from the vent connection.

Note. Combined feed and vent pipes may also be fitted.

There should be a minimum height - 450 mm (18 in.) of open vent above the cistern water level. If this is not possible then refer to Frame 14. The vertical distance between the highest point of the system and the feed / expansion cistern water level MUST not be less than 450 mm (18 in.)

The pump must be fitted on the flow side of the boiler.

A suitable pump is a domestic circulator capable of providing an 11°C (20°F) temperature differential (e.g. Grundfoss UPS 15/50 or equivalent).

The vertical distance between the pump and the feed / expansion cistern MUST comply with the pump Manufacturer's minimum requirements to avoid cavitation.

Isolation valves should be fitted as close to the pump as possible.

Should these conditions not apply, either lower the pump position or raise the cistern above the pump.

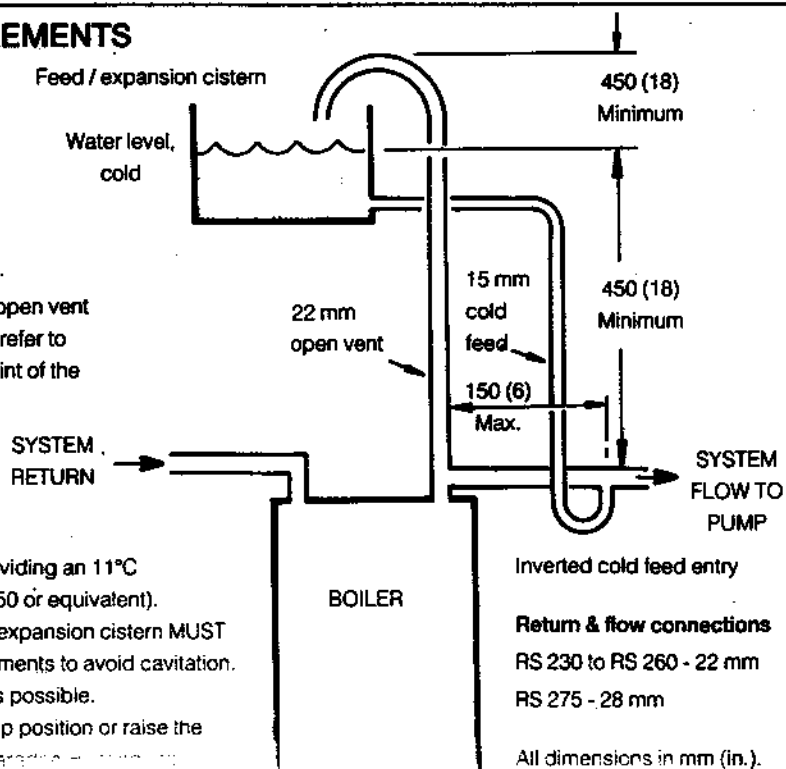

14 LOW HEAD INSTALLATIONS - OPEN VENT

The Ideal Elan 2 RS range of boilers can be installed in low head situations by fitting a surge arrester in the expansion pipe.

The following conditions **MUST** be observed.

1. The surge arrester must be at least 42 mm diameter x 150 mm long.
 2. The cistern water level must be at least 200 mm above the highest point of the system.
 3. The height of water in the surge arrester must be at least 75 mm.
 4. The vent connection must **NOT** be made directly off the top of the boiler.
- Note.** The pump manufacturer's minimum requirements must be complied with.

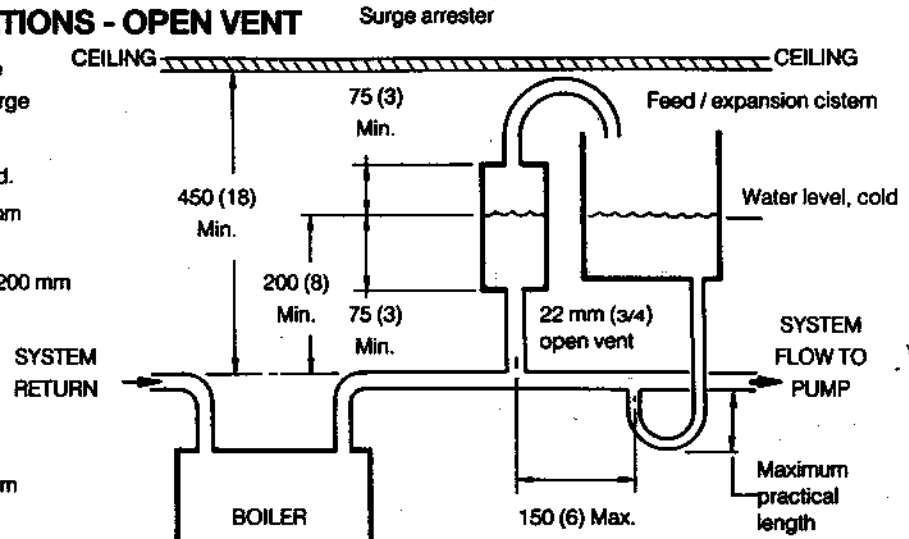

15 SCHEMATIC PIPEWORK AND BY-PASS ADJUSTMENT - OPEN VENT

WATER FLOW RATE AND PRESSURE LOSS

Boiler size		RS 230	RS 240	RS 250	RS 260	RS 275
Boiler output	kW (Btu/h)	8.8 (30 000)	11.7 (40 000)	14.7 (50 000)	17.6 (60 000)	22.6 (75 000)
Water flow rate for 11° C differential	l/min. (gal./h)	11.4 (150)	15.2 (200)	19.0 (250)	22.8 (300)	28.5 (375)
Pressure loss for 11° C differential	mbar (in.w.g)	27 (11)	45 (18)	70 (28)	102 (41)	80 (32)
Water flow rate for 9° C differential	l/min. (gal./h)	13.8 (183)	18.5 (244)	23.2 (306)	27.8 (367)	34.6 (458)
Pressure loss for 9° C differential	mbar (in.w.g)	40 (16.4)	67 (26.9)	105 (41.8)	152 (61.2)	120 (47.8)

1. The temperature differential across the boiler **MUST NOT** be more than 11° C.
2. When the RS 260 (with output above 16.1 kW (55 000 Btu/h)) and RS 275 units are used, 28 mm (1 in.) flow and return pipes **MUST** be used - both to and from the boiler.
3. The control system used with the boiler **MUST** provide a load in circuit with the boiler of at least 10 % of the boiler output whenever the boiler fires. In order to achieve this load it may be necessary to provide 'uncontrolled' radiator(s) which cannot be manually turned off by the user.
4. A by-pass **MUST** be fitted as far from the boiler as possible, consisting of the following:
 - (a) 15 mm pipe not more than 1 metre long for boilers up to 50,000 Btu/h output.
 - (b) 22 mm pipe for boilers of over 60,000 Btu/h output.

The by-pass should incorporate a balancing valve which **CANNOT** be adjusted by the householder.
5. The circulating pump used should have adequate performance to give a maximum temperature differential across the boiler of 9° C when the by-pass & the 'uncontrolled' radiator(s) (when fitted) are closed, with either the heating or the domestic hot water controls calling for heat.

BY-PASS ADJUSTMENT

6. With the heating circuit **OPEN** and the by-pass and 'uncontrolled' radiator(s) (if fitted) **CLOSED**, set the pump to give a maximum of 9° C differential across the boiler and system. The system should be at full temperature for this operation and this is a convenient point to balance the system flows.

7. Open the valve on the 'uncontrolled' radiator(s) (if fitted) and set its temperature differential to approximately 10° C.

8. Open the by-pass until the differential across the boiler is 11° C.

9. Check that the water flow through the boiler is adequate when the heating controls are satisfied and the domestic hot water controls are calling for heat.

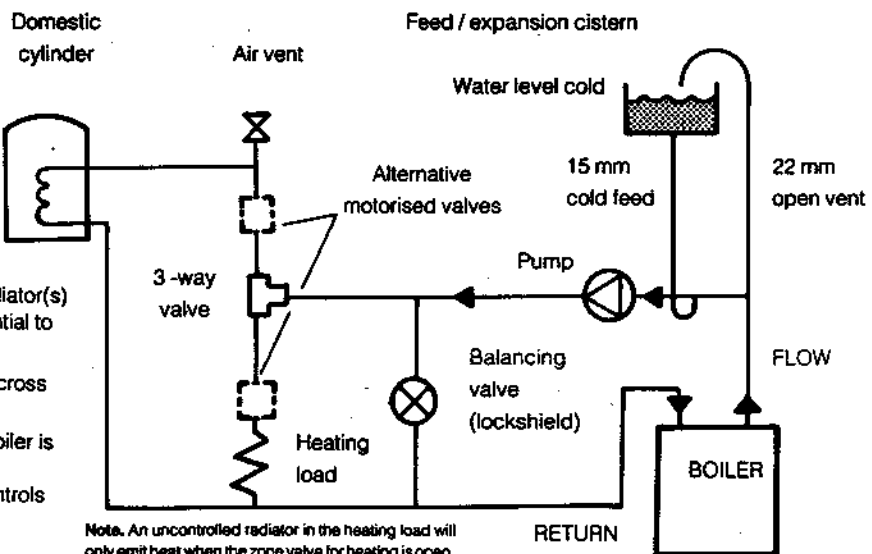

Thermostatic Radiator Valves

Caradon Heating Ltd. support the recommendations made in BS. 5449 and by leading manufacturers of domestic heating controls that heating systems utilising the full thermostatic radiator valve control of temperature in individual rooms should also be fitted with a room thermostat controlling the temperature in a space served by radiators not fitted with such a valve.

Such an arrangement will provide for a potentially more efficient control of the environment and will also avoid the continuous running of the circulation pump during programmed heating 'ON' periods - thus saving electrical energy. It is therefore strongly recommended that, when thermostatic radiator valves are used, space heating temperature control over a living / dining area or a hallway having a heating requirement of at least 10 % of the boiler heat output is achieved using a room thermostat whilst other rooms are individually controlled by thermostatic radiator valves. If a room thermostat is not fitted as described above then the system should have an uncontrolled radiator having a minimum heat loss of 10 % of the boiler's output.

16 SEALED SYSTEM REQUIREMENTS

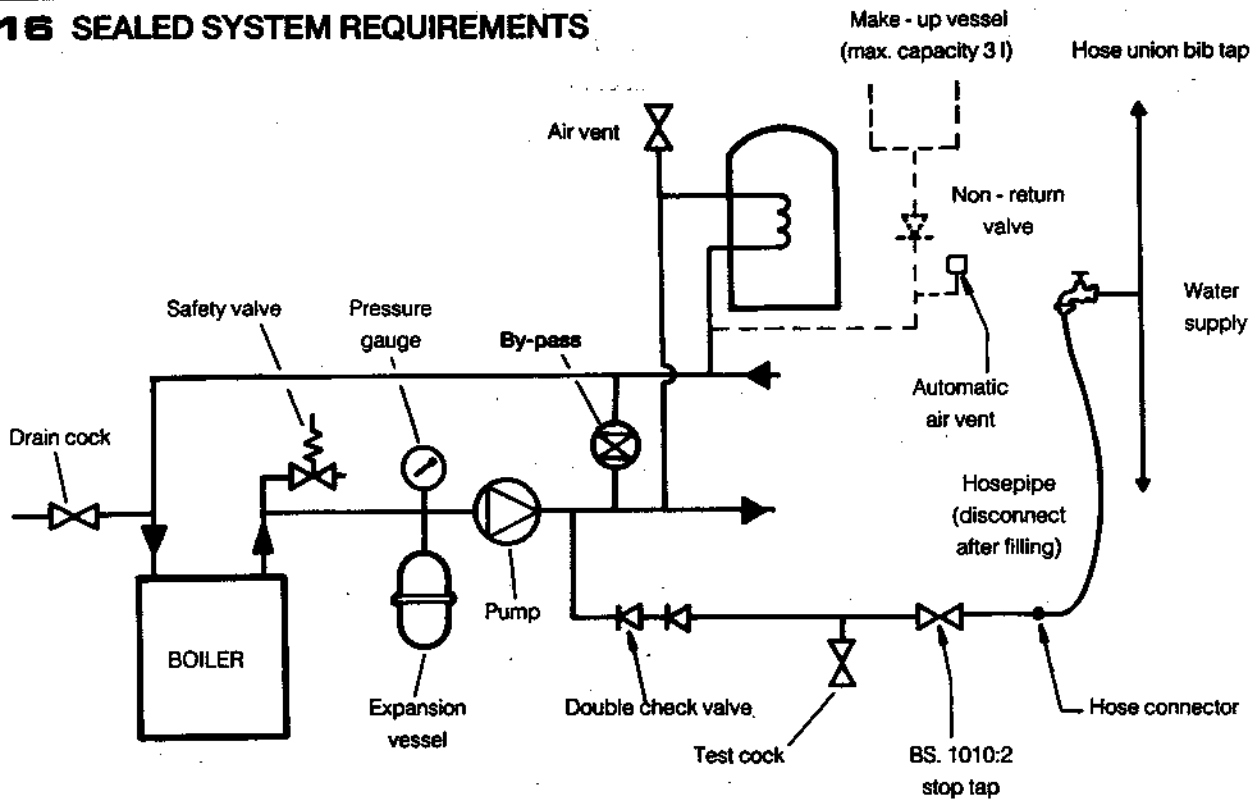

Notes.

- A. Any connection for filling or replenishing of a sealed primary circuit from a supply pipe is conditional upon a water undertaking seeking and obtaining consent for a relaxation of its Byelaws 38.8 (1), from the Secretary of State.
- B. The method of filling, re-filling, topping up or flushing sealed primary hot water circuits from the mains via a temporary hose connection is only allowed if acceptable to the Local Water Authority.

1. General.

- (a) The installation must comply with the requirements of BS. 6798 and BS. 5449.
- (b) The installation should be designed to work with flow temperatures of up to 82° C.
- (c) All components of the system, including the heat exchanger of the indirect cylinder, must be suitable for a working pressure of 3 bar (45 lb.ft. / in²) and temperature of 110° C. Care should be taken in making all connections so that the risk of leakage is minimised.

2. Safety Valve.

A spring loaded safety valve complying with the relevant requirements of BS. 6759 must be fitted in the flow pipe as close to the boiler as possible and with no intervening valve or restriction. The valve should have the following features:

- (a) A non-adjustable pre-set lift pressure not exceeding 3 bar (45 lb.ft. / in²).
- (b) A manual testing device.
- (c) Provision for connection of a discharge pipe.
The valve or discharge pipe should be positioned such that the discharge of water or steam cannot create a hazard to the occupants of the premises, or cause damage to electrical components and wiring.

3. Pressure Gauge.

A pressure gauge covering at least the range 0 - 4 bar (0 - 60 lb.ft. / in²) must be fitted to the system. The gauge should be easily seen from the fitting point and should preferably be connected to the system as the expansion vessel.

4. Expansion Vessel.

- (a) A diaphragm type expansion vessel must be connected at a point close to the inlet side of the pump, the connecting pipe being not less than 15 mm (1/2 in. nominal) size and not incorporating valves of any sort.
- (b) The vessel capacity must be adequate to accept the expansion of the system water when heated to 110° C (230° F).
- (c) The charge pressure must not be less than the static water head above the vessel. The pressure attained in the system when heated to 110° C (230° F) should be at least 0.35 bar (5 lb.ft. / in²) less than the lift pressure of the safety valve.

For guidance on vessel sizing refer to the Table in Frame 17.

For further details refer to BS. 5449, BS. 7074:1 & the British Gas Corporation publication - 'Material and Installation Specifications for Domestic Central Heating & Hot Water'.

5. Cylinder.

The cylinder must be either of the indirect coil type or a direct cylinder fitted with an immersion calorifier, which is suitable for operating on a gauge pressure of 0.35 bar (5 lb.ft. / in²) in excess of the safety valve setting. Single feed indirect cylinders are not suitable for sealed systems.

6. Make-up Water.

Provision must be made for replacing water loss from the system either,

- (a) From a manually filled make-up vessel with a readily visible water level. The vessel should be mounted at least 150 mm (6 in.) above the highest point of the system, and be connected through a non-return valve to the system, fitted at least 300 mm (12 in.) below the make-up vessel on the return side of the domestic hot water cylinder or radiators.
- (b) Where access to a make-up vessel would be difficult, by pre-pressurisation of the system. Refer to 'Filling'.

7. Mains Connection.

There must be no direct connection to the mains water supply or to the water storage tank supplying domestic water, even through a non-return valve, without the approval of the Local Water Authority.

17 SEALED SYSTEM REQUIREMENTS

8. Filling.

The system may be filled by one of the following methods:

(a) Through a cistern, used for no other purposes, via a ball valve permanently connected directly to a service pipe and / or a cold water distributing pipe.

The static head available from the cistern should be adequate to provide the desired initial system design pressure. The cold feed pipe from the cistern should include a non-return valve & a stop valve with an automatic air vent connected between them, the stop valve being located between the system & the automatic air vent. The stop valve may remain open during normal operation of the system if automatic water make-up is required.

(b) Through a self-contained unit comprising a cistern, pressure booster pump if required, and if necessary, an automatic pressure reducing valve and flow restrictor. The cistern should be supplied through a temporary connection from a service pipe or cold water distributing pipe.

This unit may remain permanently connected to the heating system to provide limited automatic water make-up. Where the temporary connection is supplied from a service pipe or distributing pipe which also supplies other 'draw-off' points at a lower level then a double check valve shall be installed upstream of the draw off point.

(c) Through a temporary hose connection from a draw off tap supplied from a service pipe under mains pressure. Where the mains pressure is excessive a pressure reducing valve shall be used to facilitate filling.

The following fittings shall form a permanent part of the system and shall be fitted in the order stated.

A stop valve complying with the requirements of BS. 1010 Part 2 (the hose from the draw off tap shall be connected to this fitting).

A test cock.

A double check valve of an approved type.

- Thoroughly flush out the whole of the system with cold water without the pump in position.
- With the pump fitted, fill & vent the system until the pressure gauge registers 1.5 bar (21.5 lb.ft. / in²), Examine for leaks.
- Check the operation of the safety valve by manually raising the water pressure until the valve lifts. This should occur within ± 0.3 bar (± 4.3 lb.ft. / in²) of the pre-set lift pressure.
- Release water from the system until the initial system design pressure is reached.
- Light the boiler and heat the system to the maximum working temperature. Examine for leaks.
- Turn off the boiler and drain the system while still hot.
- Refill and vent the system.
- Adjust the initial pressure to the required value.

Sizing procedure for expansion vessels: The volume of the expansion vessel (litres) fitted to a sealed system shall not be less than that given by the table below multiplied by a factor of 0.8 (for flow temperatures of less than 88° C).

Safety valve setting	3.0 bar			3.5 bar			3.5 bar	
Vessel charge and initial system pressure	0.5 bar	1.0 bar	1.5 bar	0.5 bar	1.0 bar	1.5 bar	0.5 bar	1.0 bar
Total water content of system	Expansion vessel volume (litres)							
25 (litres)	2.1	2.7	3.9	2.3	3.3	5.9	2.8	5.0
50	4.2	5.4	7.8	4.7	6.7	11.8	5.6	10.0
75	6.3	8.2	11.7	7.0	10.0	17.7	8.4	15.0
100	8.3	10.9	15.6	9.4	13.4	23.7	11.3	20.0
125	10.4	13.6	19.5	11.7	16.7	29.6	14.1	25.0
150	12.5	16.3	23.4	14.1	20.1	35.5	16.9	30.0
175	14.6	19.1	27.3	16.4	23.4	41.4	19.7	35.0
200	16.7	21.8	31.2	18.8	26.8	47.4	22.6	40.0
225	18.7	24.5	35.1	21.1	30.1	53.3	25.4	45.0
250	20.8	27.2	39.0	23.5	33.5	59.2	28.2	50.0
275	22.9	30.0	42.9	25.8	36.8	65.1	31.0	55.0
300	25.0	32.7	46.8	28.2	40.2	71.1	33.9	60.0
Multiplying factors for other system volumes	0.0833	0.109	0.156	0.094	0.134	0.237	0.113	0.20

18 ELECTRICAL CONNECTIONS

WARNING. This appliance MUST be efficiently earthed.

A mains supply of 240V ~ 50 Hz is required.

All external controls & wiring MUST be suitable for mains voltage. Wiring should be 3-core PVC insulated cable, NOT LESS than 0.75 mm² (24 x 0.2 mm) and to BS. 6500, Table 16. Wiring external to the boiler MUST be in accordance with the current I.E.E. Wiring Regulations and any Local Regulations.

The supply connection may be made via a removable plug to an unswitched shuttered socket/outlet, preferably adjacent to the boiler, & should such a plug be used for connection to the mains, it must be of the 3-pin type-wired as shown, fused at 3A & comply with the requirements of BS.1363. Alternatively, a fused double-pole switch, having a 3mm contact separation in both poles, serving only the boiler & its external controls may be used.

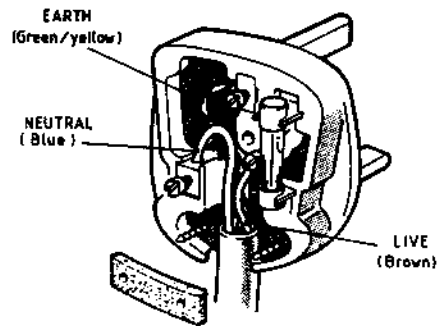

19 INTERNAL WIRING

Note. If the Programmer Kit is to be fitted, refer to the instructions provided with the kit & Frame 20.

A Pictorial Wiring diagram is shown in Frame 21 and a wiring diagram is included in the Lighting Instructions label on the casing bottom panel.

DETAIL OF BOILER CONTROL BOX

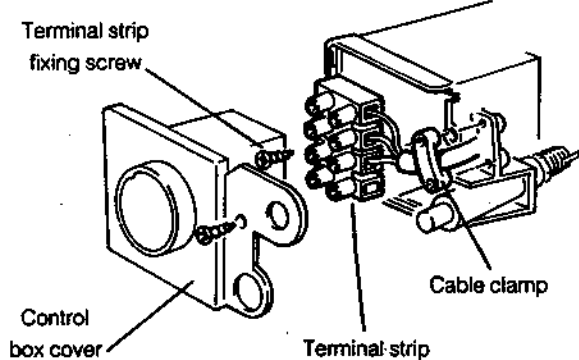

1. Remove the control box cover securing screw, disengage the lugs and draw the cover forward.

2. Remove the terminal strip securing screw, withdraw the strip & connect the mains supply into the terminals marked 'L', 'N' & '⊕'. Ensure that the earth lead is longer than the live & neutral leads and the cable is routed through the cable clamp.
3. Re-locate the terminal strip within the control box and route the mains supply lead through the slot in the control box side. Secure with the cable clamp provided. Ensure that no basic insulation is accessible outside of the control box.

Note. The mains lead connection MUST be made in such a way that, should the lead slip from the anchorage, the current-carrying conductors become taut before the earthing conductor.

4. Refit the control box cover.

FLOW WIRING DIAGRAM

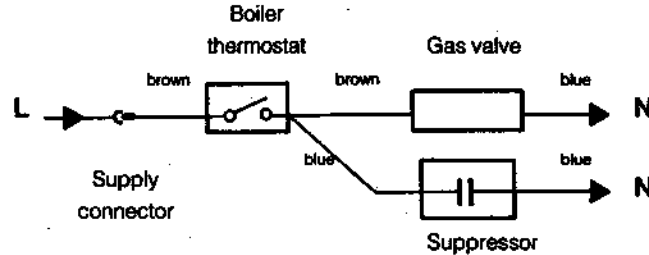

20 EXTERNAL WIRING

External wiring MUST be in accordance with the current I.E.E. Wiring Regulations.

The wiring diagrams illustrated in Frames 22 to 24 cover the systems most likely to be used with this appliance.

For wiring external controls to the **Ideal Elan 2 RS** boiler, reference should be made to the systems wiring diagram supplied by the relevant Manufacturer in conjunction with the wiring diagrams shown in Frame 21.

Difficulty in wiring should not arise, providing the following directions are observed:

1. Controls that switch the system ON & OFF, e.g. a time switch, MUST be wired in series, in the live mains lead to the boiler.
2. Controls that over-ride an ON / OFF control, e.g. a frost

thermostat, MUST be wired into the mains lead in parallel with the controls to be over-ridden. Refer to Frame 25.

3. If a proprietary system is used, follow the instructions supplied by the Manufacturers.
4. The pump must always be wired in 'parallel' with the boiler.
5. System designs featuring controls or wiring arrangements which allow the boiler to fire when there is no pumped circulation taking place, should not be fitted.

Advice on required modifications to wiring may be obtained from the component Manufacturers.

- Connections between a frost thermostat and the time control should be made without disturbing other wiring.
- A frost thermostat should be sited in a cool place in the house, but where it can sense heat from the system.

21 PICTORIAL WIRING

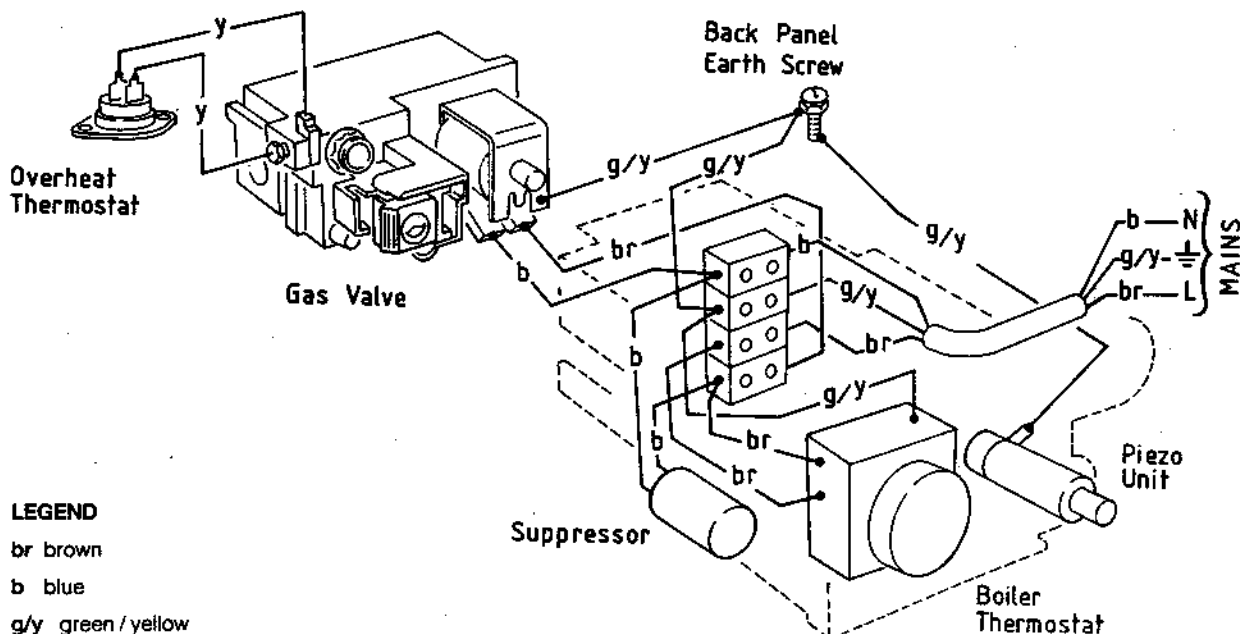

LEGEND

- br brown
- b blue
- g/y green / yellow
- y yellow

23 ONE VALVE IN HEATING CIRCUIT - Pumped only

1. Some earth wires are omitted for clarity. Ensure proper earth continuity when wiring.
2. Numbering of thermostat terminals applies ONLY to the Manufacturer mentioned.
3. Switchmaster valve also has grey and orange wires, but the GREY wire (not the orange), must be connected to the incoming supply.

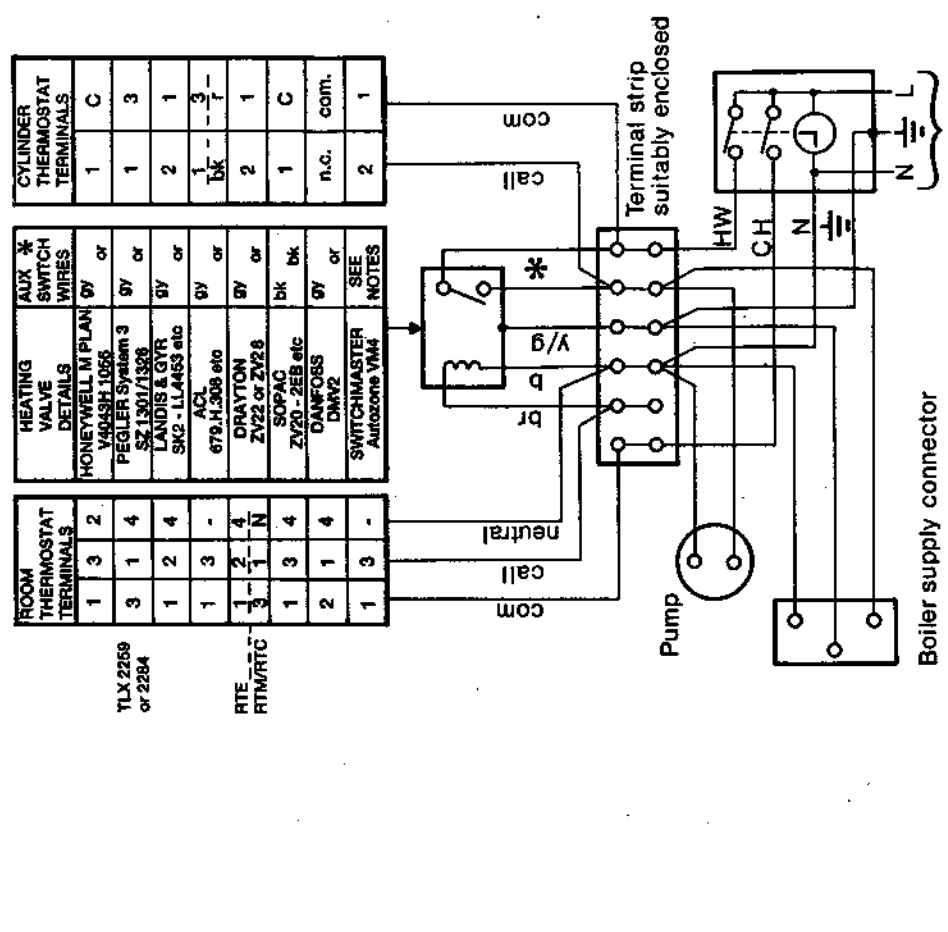

- LEGEND
- b blue
 - r red
 - g/y green or orange
 - ØV yellow
 - bk black
 - w white
 - y yellow
 - g grey
 - v violet
 - ØV grey
 - pk pink
- Typical Programmer
CH Cannot be selected without HW

22 MID POSITION VALVE - Pumped only

1. Some earth wires are omitted for clarity. Ensure proper earth continuity when wiring.
- This is a fully controlled system - set the boiler thermostat to HIGH.
- Numbering of thermostat terminals applies ONLY to the Manufacturer mentioned.
- Switchmaster Midi operates similarly, but the wiring is not identical - see the manufacturer's wiring diagram.

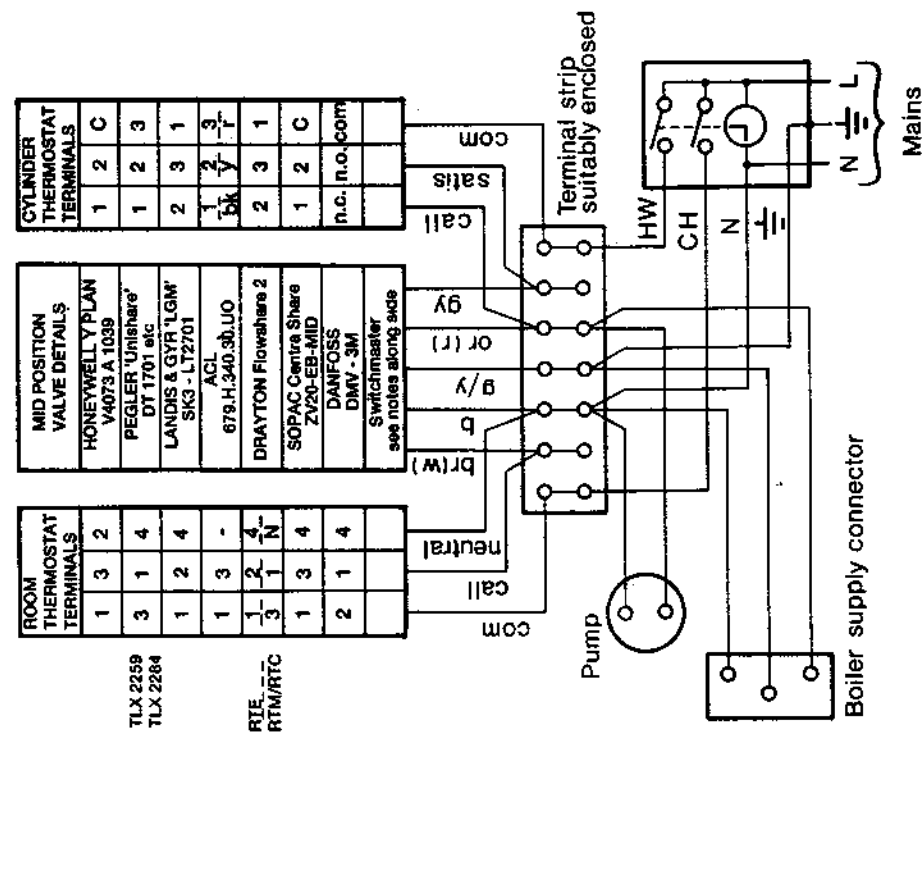

- LEGEND
- b blue
 - r red
 - g/y green or orange
 - ØV yellow
 - bk black
 - w white
 - y yellow
 - g grey
 - v violet
 - ØV grey
 - pk pink
- Typical Programmer
CH Cannot be selected without HW

25 FROST PROTECTION

1. The frost thermostat should be wired to the programmer as shown, without disturbing the existing wiring.
2. The frost thermostat should be sited in a cool place in the house, but where it can sense heat from the system.
3. The occupier should be advised that, during frosty weather, the system should be turned OFF at the programmer switches ONLY. All other controls should be left in the normal running position.

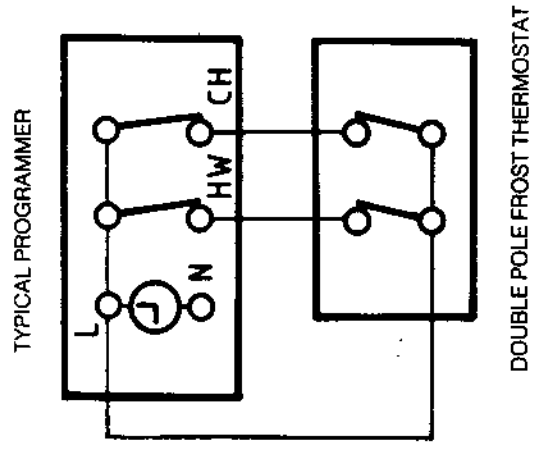

24 TWO SPRING CLOSED VALVES - Pumped only

1. Some earth wires are omitted for clarity. Ensure proper earth continuity when wiring.
2. This is a fully controlled system - set the boiler thermostat to HIGH.
3. Numbering of thermostat terminals applies ONLY to the Manufacturer mentioned.
4. Switchmaster Autozone also has grey and orange wires, but the GREY (not the orange) wire must be connected to the incoming live supply.

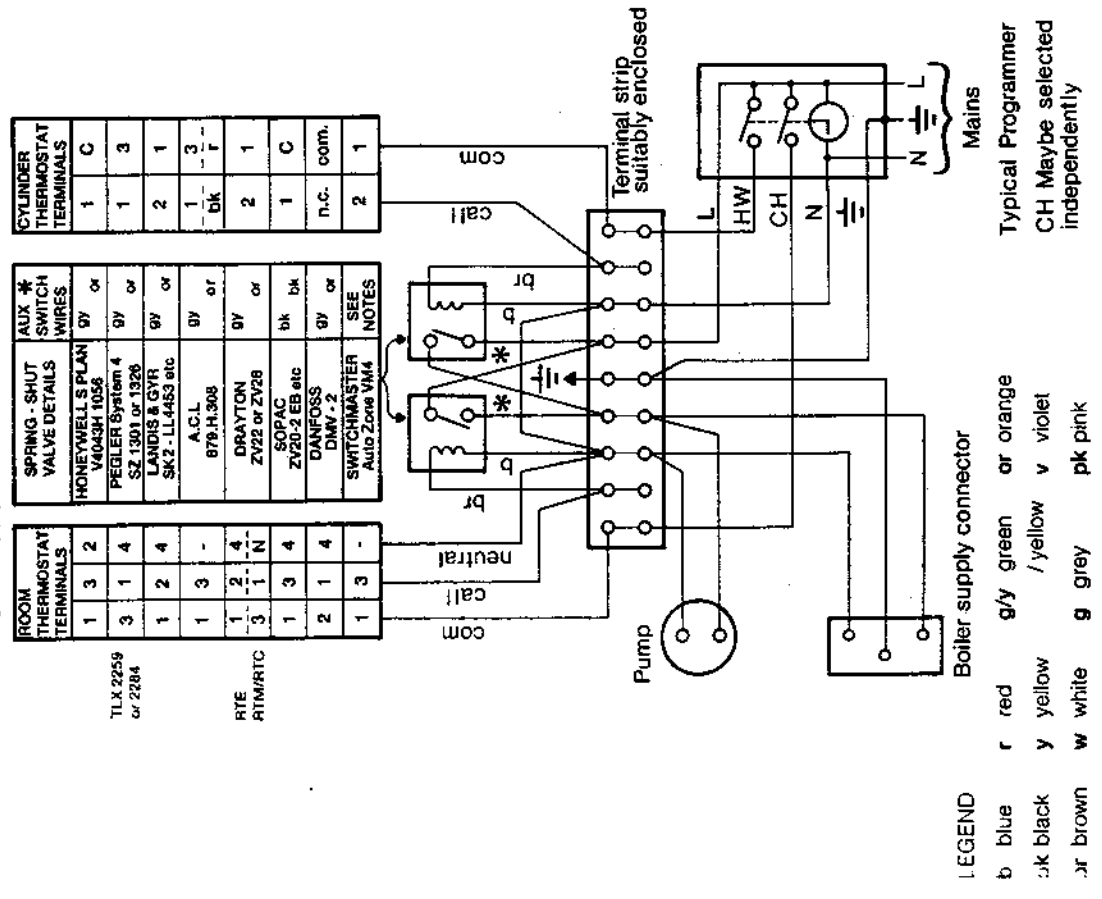

26 COMMISSIONING AND TESTING

(a) Electrical Installation

1. Checks to ensure electrical safety should be carried out by a competent person.
2. ALWAYS carry out the preliminary electrical system checks, i.e. earth continuity, polarity, resistance to earth and short circuit, using a suitable test meter.

(b) Gas Installation

1. The whole of the gas installation, including the meter, should be inspected & tested for soundness and purged in accordance with the recommendations of BS. 6891.
2. Purge air from the gas installation by loosening the four extended nuts securing the gas service cock and purging until gas is smelled.
3. Retighten the nuts and test for gas soundness.

WARNING. Whilst effecting the required gas soundness test & purging air from the gas installation, open all windows & doors, extinguish naked lights & DO NOT SMOKE.

27 INITIAL LIGHTING

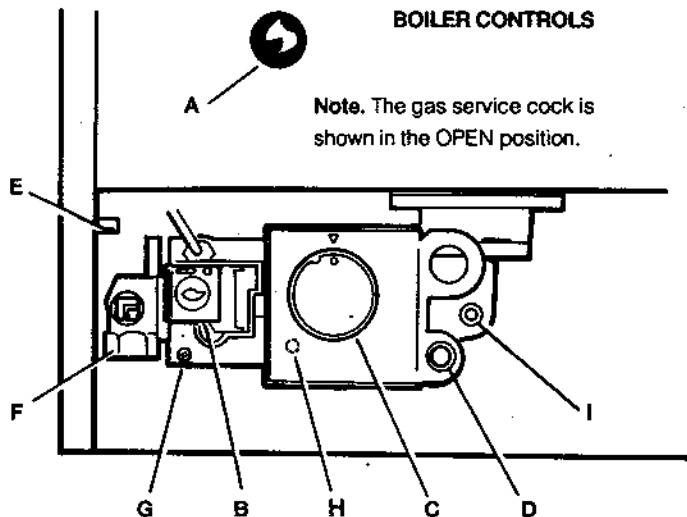

- LEGEND**
- | | |
|-----------------------------|-------------------------------------|
| A Sightglass. | E Fascia retention catch. |
| B Gas control valve button. | F Gas service cock. |
| C Thermostat knob. | G Inlet pressure test nipple. |
| D Piezo ignition button. | H Main burner pressure adjuster. |
| | I Main burner pressure test nipple. |

1. Check that the electricity supply is OFF.
2. Check that the gas service cock (F) is ON and the boiler thermostat control knob (C) is OFF.
3. Slacken the screw in the burner pressure test nipple (I) and connect a gas pressure gauge via a flexible tube.
4. Slide the gas control button (B) to the RIGHT until resistance is felt and then release it.
5. Push in and retain fully depressed the gas control button (B), press and release the piezo ignition button (D) repeatedly until the pilot lights.
6. Hold the gas control button (B) depressed for 15 seconds after the pilot burner has ignited.
7. If the pilot burner fails to remain alight at this stage then repeat the procedure detailed above, but wait longer than 15 seconds before releasing the gas control button.
8. Check the appearance of the pilot flame to ensure that it envelops the tip of the thermocouple and is approximately 25mm (1 in.) long. If the pilot flame appears incorrect then refer to Frame 7 of 'Servicing'.
 - (a) The pilot flame is factory set & no adjustment is possible.
 - (b) The recommended range of thermocouple output is 8-15 mV closed circuit.
9. Test for gas soundness around ALL boiler gas components

10. Set the boiler thermostat knob (C) to OFF and switch OFF the electricity supply.
11. If the boiler output is to be set to MID or MINIMUM, affix the appropriate output indicator to the Data Plate, located on the bottom R.H. side of the back panel:

FITTING THE BOILER CASING

IMPORTANT. This appliance **MUST NOT** be operated with the casing removed.

12. Lift the boiler casing, with the glass fascia in the down position, up to the boiler assembly and secure with the top captive screw.

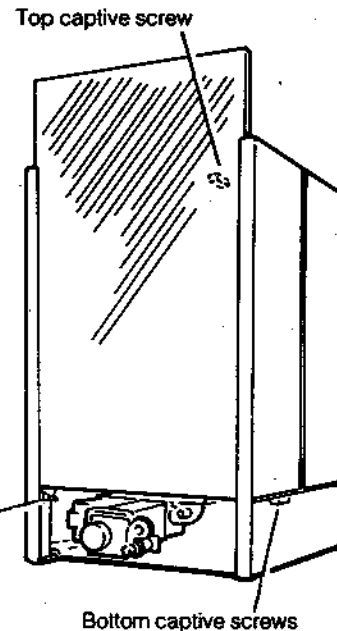

13. Slide the fascia up until it locates in the retaining catch.

14. Secure the bottom two captive screws.

The casing **MUST** seat correctly and compress the sealing strip to make an airtight joint. If the side clearance is limited then this may be checked by ensuring that the top and bottom edges of the casing are correctly located.
15. Switch the electricity supply ON and check that all external controls are calling for heat.
16. Set the boiler thermostat knob (C) to position '6' and check that the main burner cross lights smoothly from the pilot flame.
17. Operate the boiler for ten minutes to stabilise the burner temperature.
18. The boiler is pre-set at the factory to its highest nominal rating, but can be range rated to suit the system design requirements. Refer to Table 2 on page 2.

Turn the adjusting screw (H) **CLOCKWISE** to **DECREASE** the pressure.
19. Set the boiler thermostat knob (C) to OFF.
20. Remove pressure gauge and tube.

Retighten the sealing screw in the pressure test nipple - ensure that a gas-tight seal is made

28 GENERAL CHECKS

Make the following checks for correct operation:

1. Turn the boiler thermostat knob ON and OFF. Check that the main burner lights and extinguishes in response.
2. The correct operation of ANY programmer and all other system controls should be proved. Operate each control separately and check that the main burner or circulating pump, as the case may be, responds.
3. **Flame Failure Device.**
Check the operation of the flame device in the gas control valve as follows:
 - (a) Extinguish the pilot flame by closing the gas service cock (F) and note the time taken for the flame failure device to shut down - identified by a click within the gas control valve. This MUST NOT be longer than 60 seconds.
 - (b) Open the gas service cock and re-light the pilot.
 - (c) Set the boiler thermostat knob (C) to position '6' and the burner should light.
 - (d) Slide the gas control button (B) to the RIGHT until resistance is felt and then release it. The main burner and pilot flame should shut down immediately.
Note. A latch in the gas control valve provides a safety delay period of approximately 30 seconds before the boiler can be re-lit.
3. Check that the casing is sealed correctly and compressing the sealing strip all around the casing.

4. Water Circulation System

- (a) With the system HOT, examine all water connections for soundness.
 - (b) With the system still hot, turn off the gas, water and electricity supplies to the boiler and drain down in order to complete the flushing process.
 - (c) Re-fill and vent the system, clear all air locks and again check for water soundness.
 - (d) Balance the system and set the by-pass.
5. Finally set the controls to the User's requirements and slide the glass fascia down into the closed position.
- If an optional Programmer Kit is fitted then refer to the instructions supplied with the kit.
 - The temperatures quoted below are approximate and vary between installations.

Knob Setting	Flow Temperature	
	°C	°F
1	56	133
2	61	142
3	66	152
4	72	161
5	77	170
6	82	180

WARNING. The boiler MUST NOT be operated with the casing removed.

29 HANDING OVER

After completing the installation and commissioning of the system, then the installer should hand over to the householder by the following actions:

1. Hand the User's Instructions to the Householder and explain his or her responsibilities under the Gas Safety (Installation and Use) Regulations 1984.
2. Draw attention to the Lighting Instruction label affixed to the casing front and visible through the observation window in the glass fascia when in the raised position.
3. Explain and demonstrate the lighting and shutting down procedures.
4. The operation of the boiler and the use and adjustment of ALL system controls should be fully explained to the Householder, to ensure the greatest possible fuel economy, consistent with household requirements of both heating and hot water consumption.

Advise the User of the precautions necessary to prevent damage to the system and to the building, in the event of the system remaining inoperative during frosty conditions.

5. Explain the function and the use of the boiler thermostat and external controls.
6. Explain the function of the boiler over-heat thermostat and emphasise that if cut-out persists, the boiler should be turned off and the local Heating Installer consulted.
7. Explain and demonstrate the function of time and temperature controls, radiator valves, etc for the economic use of the system.
8. If any Programmer Kit is fitted, then draw attention to the Programmer Kit User's instructions and hand them to the Householder.
9. Stress the importance of regular servicing by the Local Gas Region or by a qualified Heating Engineer and that a comprehensive service should be carried out AT LEAST ONCE A YEAR.

1 SCHEDULE

To ensure the continued safe and efficient operation of the appliance, it is recommended that it is checked at regular intervals and serviced as necessary. The frequency of servicing will depend upon the installation condition and usage, but should be carried out at least annually. It is the law that any service work must be carried out by a competent person.

- (a) Light the boiler and carry out a pre-service check, noting any operational faults.
- (b) Clean the main burner.
- (c) Clean the heat exchanger.
- (d) Clean the main and pilot injectors.
- (e) Check the condition of the thermocouple.
- (f) Check that the flue terminal is unobstructed and that the flue system is sealed correctly.
- (g) If the appliance has been installed in a compartment, check that the ventilation areas are clear.

The servicing procedures are covered more fully in Frames 2 to 7 and must be carried out in sequence.

WARNING. Always turn OFF the gas service cock and disconnect the electrical supply BEFORE servicing.

IMPORTANT. After completing the servicing or exchange of components always test for gas soundness and carry out functional checks as appropriate.

Note. In order to carry out either servicing or replacement of components, the boiler casing must be removed (Frame 2).

IMPORTANT. When work is complete the casing MUST be correctly refitted, ensuring that a good seal is made.

The boiler must NOT be operated if the casing is not fitted.

2 BOILER CASING REMOVAL

1. Release the top captive screw.
2. Slide the glass fascia upwards until it locates in the retaining catch.
3. Remove the two securing screws, slide the bottom panel forward slightly and then sideways to remove from the casing.

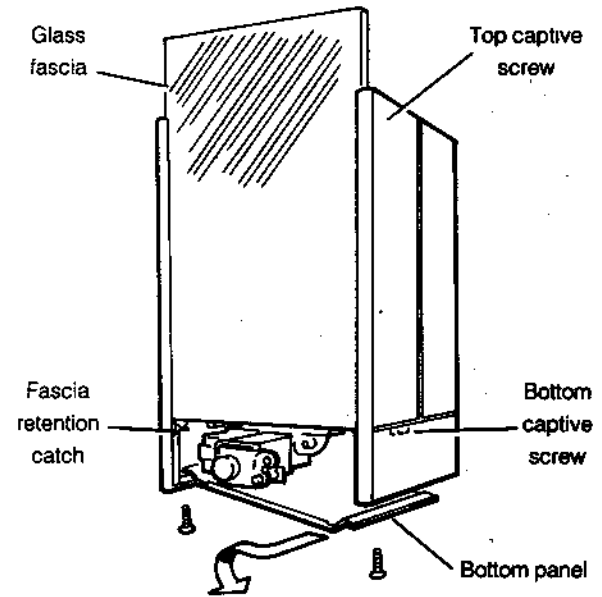

4. Release the 2 bottom captive screws and lift the casing off the boiler. Place the casing safely to one side, taking care not to damage the glass fascia panel. Slide the glass panel down in the casing for safe keeping.

3 BURNER AND AIR BOX REMOVAL

1. Remove the wing nut securing the burner front support bracket.
2. Remove the M5 pozi screw situated at the left hand, bottom rear of the burner and pull the burner downwards in order to disengage the retention tab. Remove the burner to a safe place for inspection and cleaning.
3. Unscrew the thermocouple connection at the gas control.

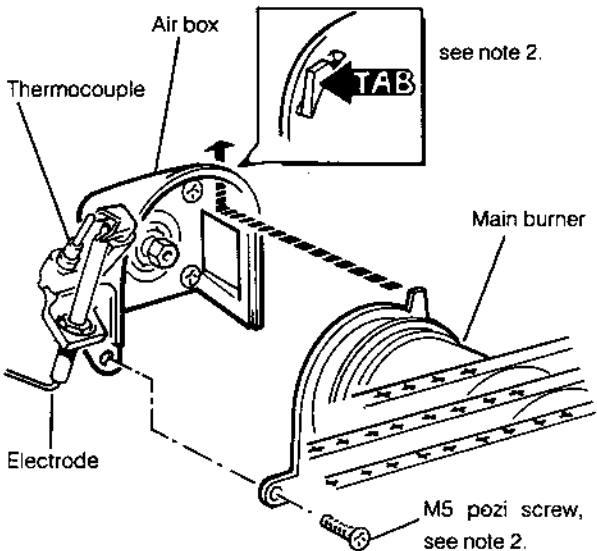

3. Remove the four screws retaining the air box / pilot assembly to the vertical manifold.
4. Pull off the electrode lead at the piezo unit.
5. Unhook the clip retaining the thermocouple and remove the thermocouple to a safe place for inspection and cleaning.

4 CLEANING THE FLUEWAYS

1. Remove the two securing screws and washers from the collector hood flange.

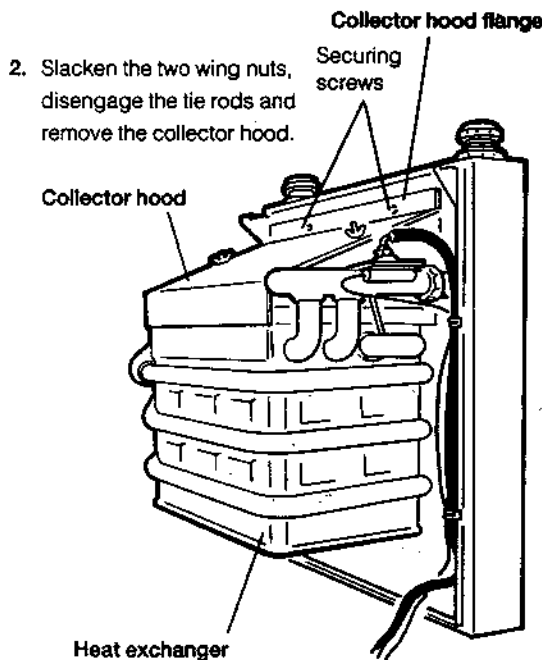

2. Slacken the two wing nuts, disengage the tie rods and remove the collector hood.
3. Place a plastic sheet or similar beneath the boiler and remove all loose deposits from the heat exchanger finned block and copper skirt using a suitable brush and / or clearing rod - brushing from above and below.
4. Check that the flue outlet duct is unobstructed

5 CLEANING THE BURNER AND PILOT ASSEMBLY

Refer to Frame 3 for illustration of the procedure below.

- Brush off any deposits that may have fallen onto the burner head, ensuring the flame ports are un-obstructed and remove any debris that may have collected.
Note. Brushes with metallic bristles **MUST NOT** be used.
- Remove the main burner injector and ensure that there is no blockage or damage. Clean or renew as necessary.
- Refit injector using an approved jointing compound sparingly.
- Inspect the pilot burner, thermocouple and spark electrode; ensure they are clear and in good condition. Check that:
 - The pilot burner injector is not blocked or damaged (refer to Frame 11 for removal details).
 - The pilot burner is clean and unobstructed.

- The spark electrode is clean and undamaged.
 - The spark lead is in good condition and securely connected.
 - The spark gap is correct. Refer Frame 7.
 - The thermocouple tip is not burned or cracked.
 - The position of the thermocouple relative to the pilot burner and main burner is correct. Refer to Frame 7.
 - The thermocouple terminal at the gas valve is clean.
- Re-assemble the burner air box assembly in reverse order. Ensure that the burner tab is correctly located, refer to Frame 3.
Note. The pilot shield is positioned around the pilot assembly bracket and is located by the electrode retaining nut.

6 RE-ASSEMBLY

Re-assemble in reverse order to that shown in Frames 2 to 5.

- Refit the flue collector hood renewing, any damaged or deteriorating sealing gasket.
- Refit the burner and air box assembly.
- Turn on the gas supply at the gas service cock.
- Re-connect the electricity supply.
- Check the sightglass in the boiler casing. Clean or renew as necessary. Refer to frame 9.
- Refit the boiler casing.

7 GAS PRESSURE ADJUSTMENT

PILOT

Light the pilot (refer to Frame 27 'Installation') and check that the pilot flame envelopes the tip of the thermocouple and is approximately 25 mm (1 in.) long.

The pilot is factory set to maximum and no further adjustment is possible. However, if the pilot flame appears small, check the pilot injector. Refer to Frame 11.

MAIN BURNER

After each occasion of servicing reference should be made to Table 2, which quotes details of the rated output, with the related burner setting pressure and the heat input. Any required adjustment should be made by using the pressure adjustment screw. Refer to Frame 27 'Installation'.

DETAIL OF PILOT BURNER FLAME LENGTH

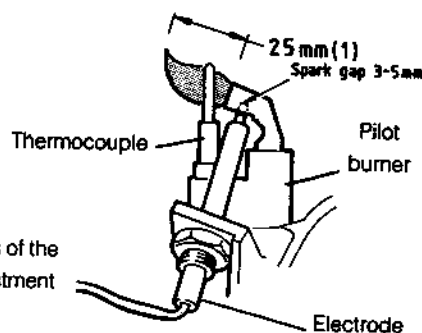

REPLACEMENT OF PARTS

8 GENERAL

When replacing any component:

- Isolate the electricity supply.
- Turn off the gas supply at the boiler, refer to the illustration below. **Note.** The gas cock is shown in the CLOSED position.

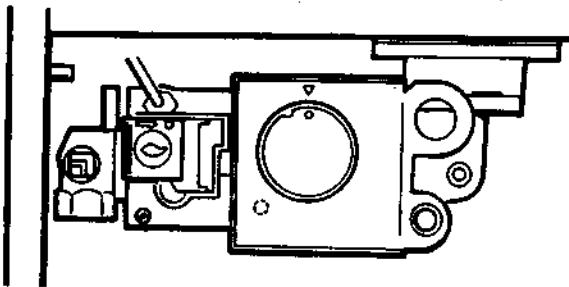

- Remove the boiler casing (refer to Frame 2).

IMPORTANT. When work is complete the casing **MUST** be correctly refitted - ensuring that a good seal is made.

*The boiler **MUST NOT** be operated if the casing is not fitted.*

9 SIGHTGLASS REPLACEMENT

- Refer to Frame 8.
- Remove the glass fascia panel from the casing.
- Unfasten the 2 nuts & washers & remove the assembly.
Note. The gas cock is shown in the CLOSED position.
- Fit the new sightglass and re-assemble as shown.
- Retighten the two nuts to ensure an airtight seal. **DO NOT OVERTIGHTEN.**
- Refit the fascia panel & replace the boiler casing (Frame 6).

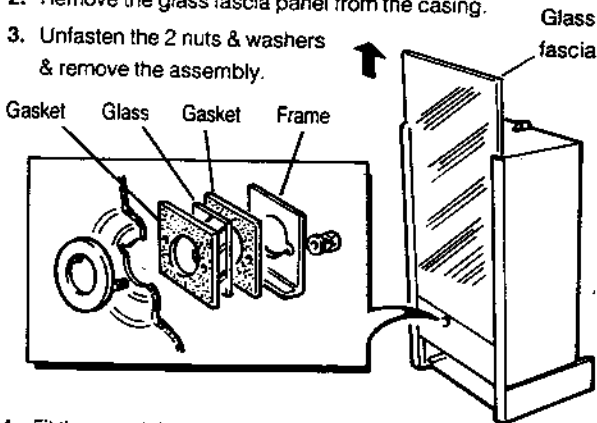

10 PIEZO UNIT REPLACEMENT

1. Refer to Frame 8.
2. Disconnect the ignition and earth leads from the Piezo unit.
3. Unscrew the locking nut at the rear of the piezo unit mounting bracket.
4. Remove the control box cover
5. Remove the piezo unit.
Re-fit the new unit and re-assemble in reverse order.
6. Replace the boiler casing. Refer to Frame 6.
7. Check the operation of the new piezo unit.

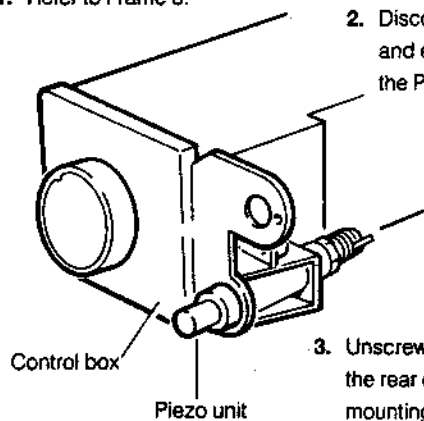

11 PILOT BURNER REPAACEMENT

1. Refer to Frame 8.
2. Remove burner and air box assembly. Refer to Frame 3.
3. Remove the electrode retaining nut. Remove the pilot shield and electrode.
4. Unscrew the central pilot fixing screw and lift the pilot clear of thermocouple and pilot injector.
If required, the pilot injector may now be unscrewed & the injector checked or replaced as necessary.
5. Replace the pilot burner and retain with the M4 screw previously removed.
6. Replace the electrode and pilot shield - retaining both with the electrode nut.
7. Replace the air box assembly and ensure that the gasket is in position.
8. Replace the burner.
9. Check the pilot burner relationship to the main burner and spark gap. Refer to Frame 7.
10. Replace the boiler casing. Refer to Frame 6.
11. Check the pilot length. Refer to Frame 7.
12. Check the pilot operation (cross lighting, holding in time, etc.).

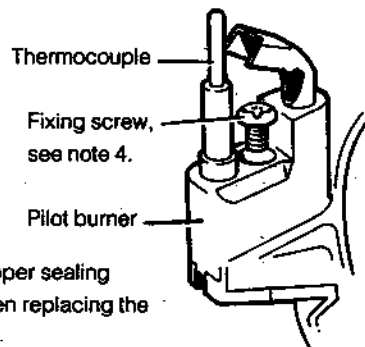
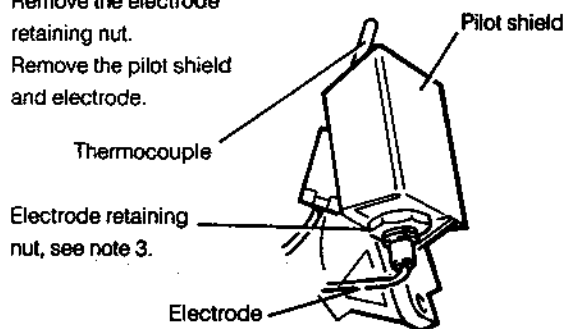

12 SUPPRESSOR REPLACEMENT

1. Refer to Frame 8.
2. Remove the screw retaining the control box cover and remove the cover, c/w with thermostat.
3. Remove the suppressor by removing the screw retaining the terminal block, lifting the terminal block and unscrewing the suppressor lead connections.
4. Fit the new suppressor and re-assemble in reverse order. Ensure that all of the electrical connections are correctly re-made - refer to 'Wiring Diagrams'.
5. Replace the boiler casing. Refer to Frame 6.
6. Check the operation of the control thermostat.

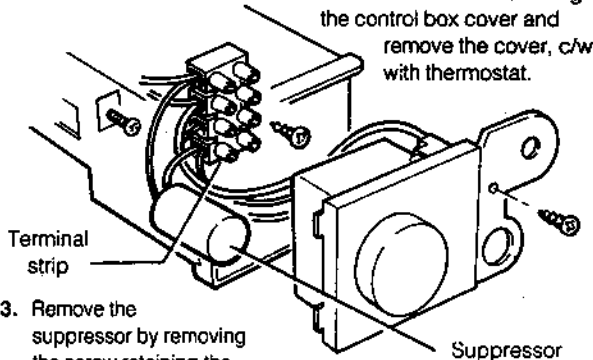

13 CONTROL THERMOSTAT REPLACEMENT

1. Refer to Frame 8.
2. Disengage the thermostat capillary from the three retaining clips on the back panel.
3. Remove the retaining cap and
4. Pull off the thermostat knob. Remove the control box cover retaining screw and remove the cover complete with thermostat.
5. Remove the two screws securing the thermostat.
6. Disconnect the electrical leads and withdraw the thermostat from the boiler.
7. Fit the new thermostat and re-fit in reverse order. Ensure that the dial is correctly replaced in the pocket and the capillary routed as previously.
8. Replace the boiler casing. Refer to frame 6.

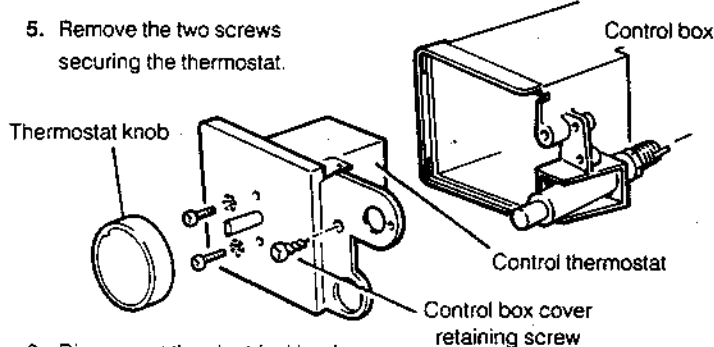
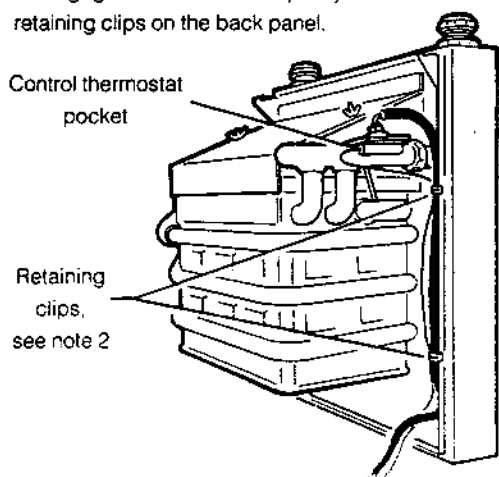

14 OVERHEAT THERMOSTAT REPLACEMENT

1. Refer to Frame 8.

DETAIL OF THERMOCOUPLE & INTERRUPTER

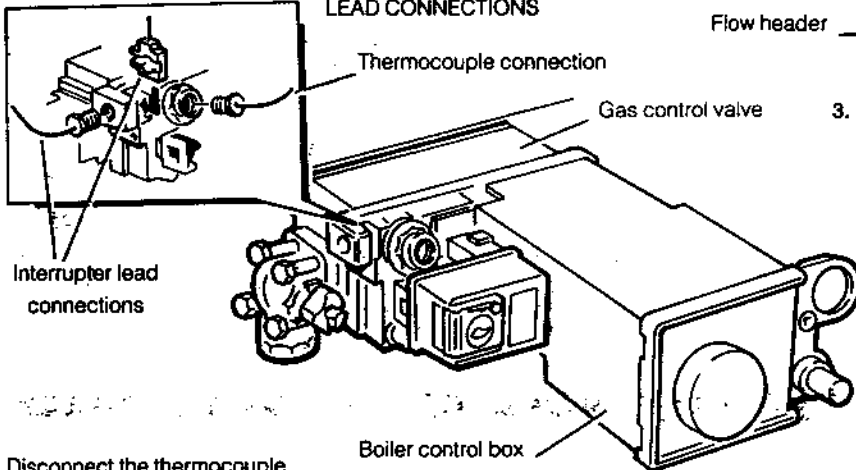

2. Disconnect the thermocouple and two interrupter leads from the gas control valve.

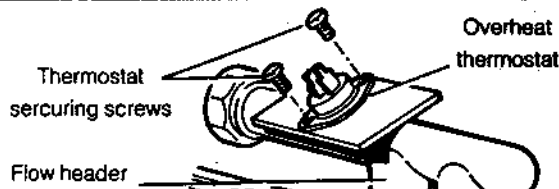

3. Remove the thermostat securing screws. To improve access to the screws it may be necessary to remove the collector hood (Refer to Frame 4 'Servicing')

4. Disengage the thermostat lead from the three retaining clips on the backpanel (refer to frame 13) and withdraw the thermostat from the boiler.

5. Fit the new thermostat and re-assemble in reverse order.

6. Replace the boiler casing. Refer to Frame 6.

15 SPARK ELECTRODE AND LEAD REPLACEMENT

1. Refer to Frame 8.

DETAIL OF PILOT BURNER

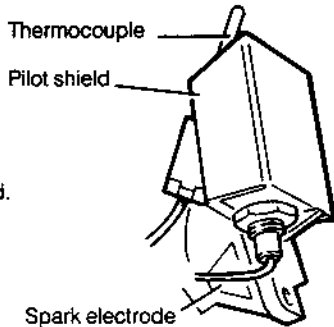

2. Remove burner and air box assembly. Refer Frame 3.

3. Remove the electrode retaining nut.

4. Remove the pilot shield.

5. Remove the spark electrode and integral lead.

6. Fit the new electrode & lead in reverse order, taking care to replace the pilot shield.

7. Check the spark gap. Refer to Frame 7.

8. Refit the burner.

9. Replace the boiler casing. Refer to Frame 6.

10. Check the pilot ignition.

16 THERMOCOUPLE REPLACEMENT

1. Refer to Frame 8.

2. Remove the burner and air box assembly. Refer to Frame 3.

3. Remove the electrode retaining nut. Refer to Frame 11.

4. Remove the pilot shield and electrode.

5. Unscrew the central pilot fixing screw. Lift the pilot clear of the thermocouple and pilot injector. Refer to Frame 11.

6. Withdraw the thermocouple and fit the replacement.

Re-assemble in reverse order, ensuring that no sharp bends are used on the thermocouple, and the pilot shield is refitted.

7. Replace the boiler casing. Refer to Frame 6.

8. Check the operation of the thermocouple.

17 MAIN BURNER AND MAIN BURNER INJECTOR REPLACEMENT

1. Refer to Frame 8.

2. Remove the wing nut securing the burner front support bracket.

3. Remove the M5 pozi screw and washer, situated at the left hand bottom rear of the burner. Pull the burner downwards to disengage the retention tab and remove the burner.

4. At this stage the main burner injector can be removed, checked, cleaned or replaced as required. Ensure that an approved jointing compound is used sparingly.

5. Fit new burner, ensuring that the retention tab is correctly located in the air box slot.

6. Refit the M5 retaining screw and washer.

7. Refit burner front support bracket.

8. Refit boiler casing. Refer to Frame 6.

9. Check the burner front lighting as follows:

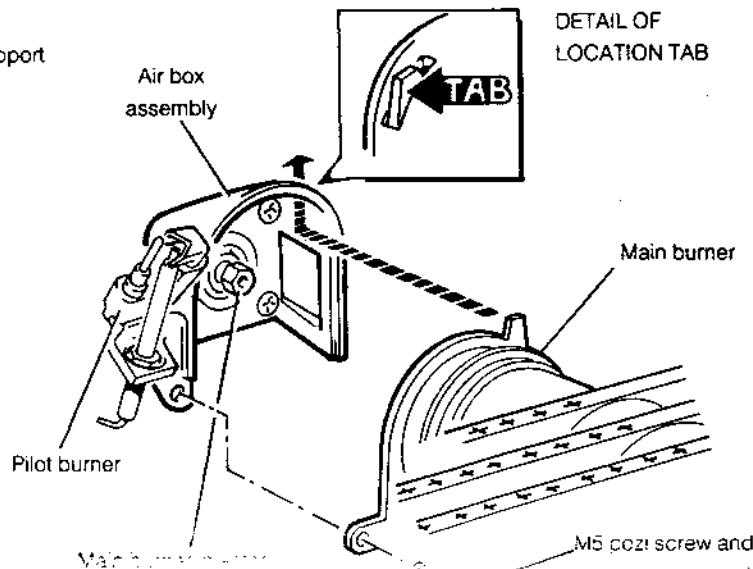

18 GAS CONTROL VALVE REPLACEMENT

Note. Also refer to Frame 24 (Servicing) 'BURNER ASSEMBLY - Exploded View' for illustration of the procedure detailed below.

1. Refer to Frame 8.
2. Remove the burner and air box assembly. Refer to Frame 3.
3. Turn off the gas supply at the service cock.
4. Remove the control box cover fixing screw and withdraw the cover.
5. Pull off the two electrical connections and the earth connection at the boiler thermostat.
6. Remove the control box central fixing screw, situated behind the suppressor and draw the box forward.

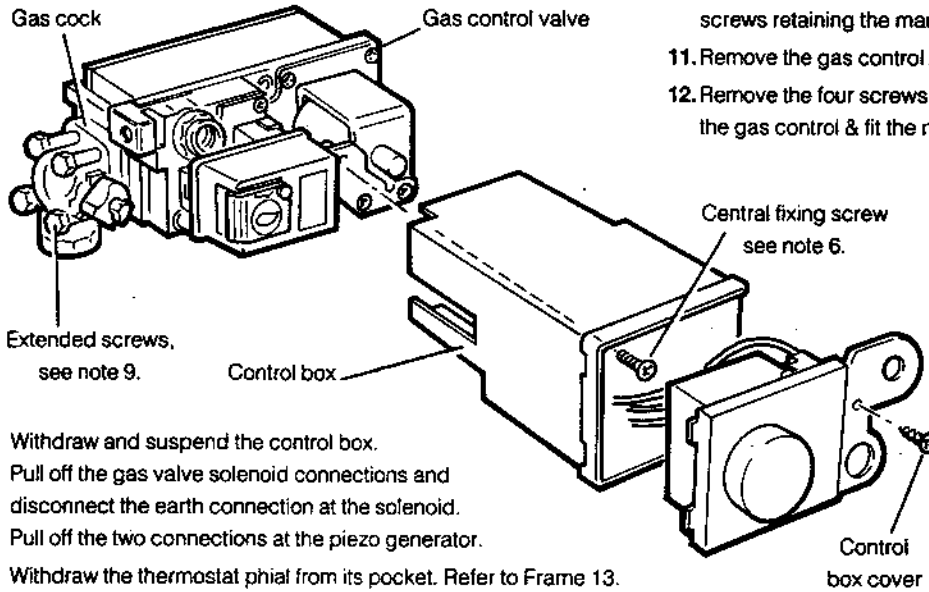

7. Withdraw and suspend the control box. Pull off the gas valve solenoid connections and disconnect the earth connection at the solenoid. Pull off the two connections at the piezo generator.
8. Withdraw the thermostat phial from its pocket. Refer to Frame 13.

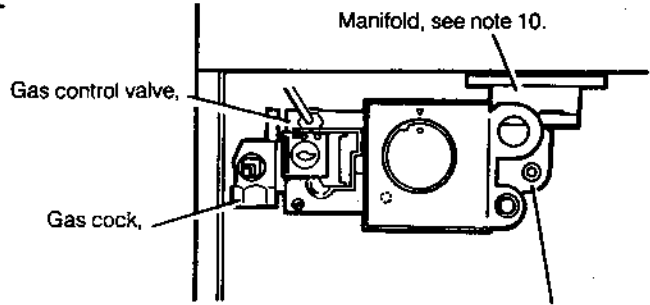

9. Remove the four M4 extended screws retaining the gas service cock to the gas control valve.
10. Whilst supporting the gas control valve, remove the two screws retaining the manifold to the back panel.
11. Remove the gas control / manifold assembly.
12. Remove the four screws retaining the manifold extension to the gas control & fit the new gas control valve, ensuring that:

- (a) The new gas control is fitted the correct way round (an arrow engraved on the valve indicates the direction of flow).
- (b) The sealing gasket and 'O' ring, supplied with the valve, are correctly fitted.

13. Re-assemble in reverse order.
14. Replace the burner and air box assembly.
15. Replace the boiler casing. Refer to Frame 6.
16. Check the gas valve operation.

19 GAS CONTROL VALVE SOLENOID REPLACEMENT

1. Refer to Frame 8.
2. Remove the control box from the gas control valve. Refer to Frame 18.
3. Slide out the spring clip and remove the solenoid and mounting bracket from the gas control valve.
4. Fit the new solenoid and re-assemble in reverse order.
5. Replace the boiler casing. Refer to Frame 6.
6. Check the gas valve operation.

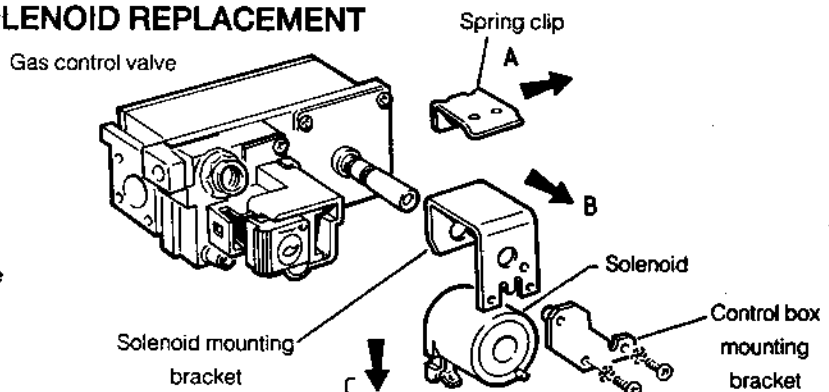

20 HEAT EXCHANGER REPLACEMENT

Note. Also refer to Frame 24 (Servicing) 'BURNER ASSEMBLY - Exploded View' for illustration of the procedure detailed below.

IMPORTANT. Before starting the removal procedure protect the gas and electrical controls with a waterproof sheet or similar.

1. Refer to Frame 8.
2. Drain down the system and heat exchanger. Refer to Frame 21.
3. Remove the burner and air box assembly. Refer to Frame 3.
4. Remove the flue collector hood. Refer to Frame 4.
5. Remove the control thermostat phial from the pocket. Refer to Frame 13.
6. Remove the overheat thermostat from the mounting plate. Refer to Frame 14.
7. Undo the heat exchanger flow and return connections.

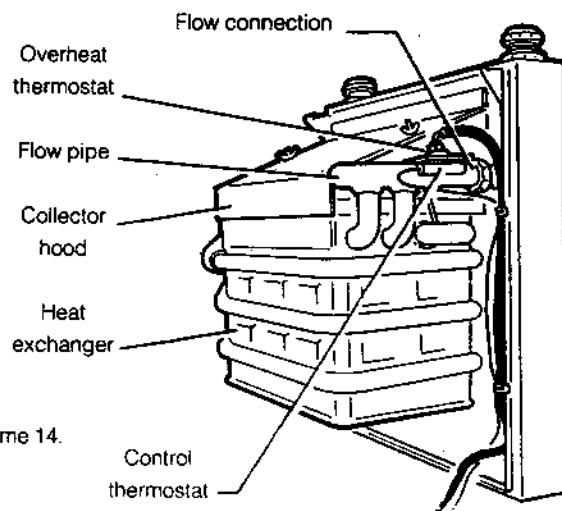

Continued in Frame 21

21 HEAT EXCHANGER REPLACEMENT

Continued from Frame 20.

7. Disengage the back of the heat exchanger skirt from the retaining bracket.
8. Ease the heat exchanger forwards and downwards and withdraw it from the interpanel.
9. Fit the new heat exchanger and re-assemble in reverse order. Renew any damaged or deteriorating flue collector hood gasket.

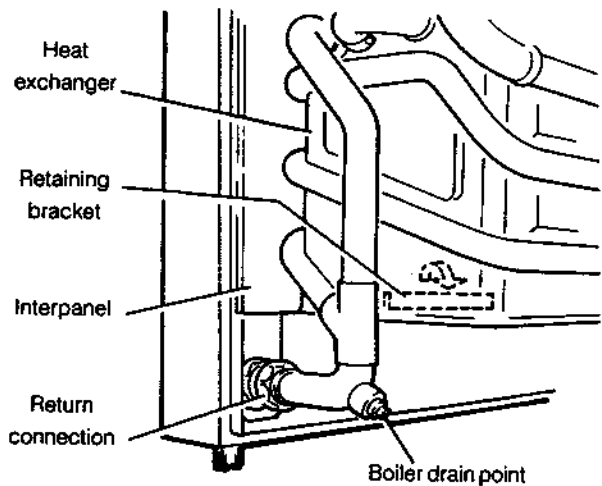

22 CASING SEAL REPLACEMENT

1. Refer to Frame 8.

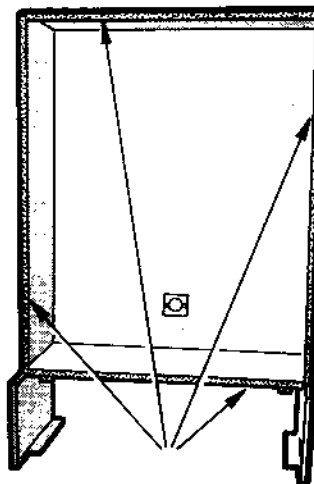

2. Remove the old seals from the channel in the casing, and press in the new seals (4 pieces).
3. Replace the boiler casing. Refer to Frame 6.

Note. Ensure that the casing is correctly seated - compressing the sealing strip to make an airtight joint. If side clearances are limited, then this can be checked by ensuring that top and bottom edges of the casing are correctly located.

23 PROGRAMMER REPLACEMENT (if fitted)

1. Refer to Frame 8.
2. Remove the boiler control box lid and release the terminal strip fixing screw. Disconnect the 'L', 'N' & '⏏' connections from the terminal strip and release the cable clamp.

DETAIL OF PROGRAMMER

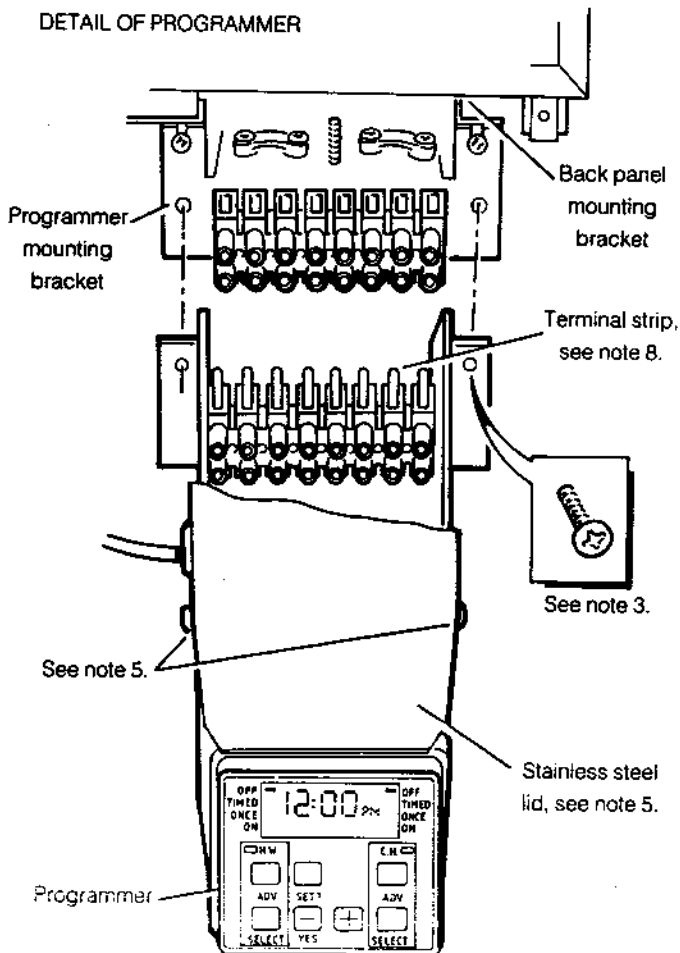

DETAIL OF BOILER CONTROL BOX

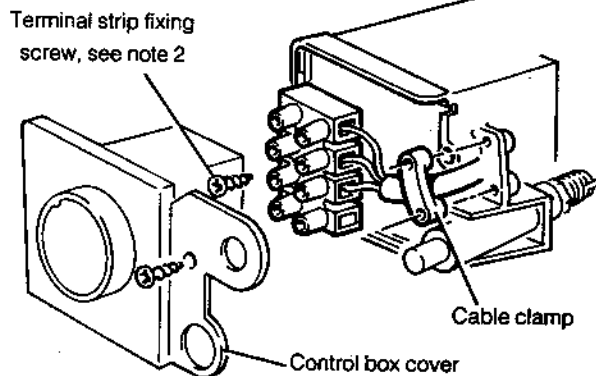

3. Remove the 2 screws retaining the programmer mounting bracket to the back panel mounting bracket.
4. Pull the programmer mounting bracket downward and forward in order to disengage the terminal strip connection.
5. Remove the 2 screws fastening the stainless steel lid to the programmer mounting bracket and remove the lid.
6. Slide the programmer upwards in order to clear the mounting bracket.
7. Remove the strain relief bush retaining the control box feed cable and remove the earth lead from the earth post.
8. Remove the 3 screws retaining the terminal strip to the programmer mounting bracket.
9. Remove the programmer, complete with its terminal strip and wiring harness.
10. Fit the new programmer, terminal strip and wiring harness in reverse order.
11. Set the programmer to the desired programme and test its functions.

24 BURNER AND CONTROLS - Exploded view

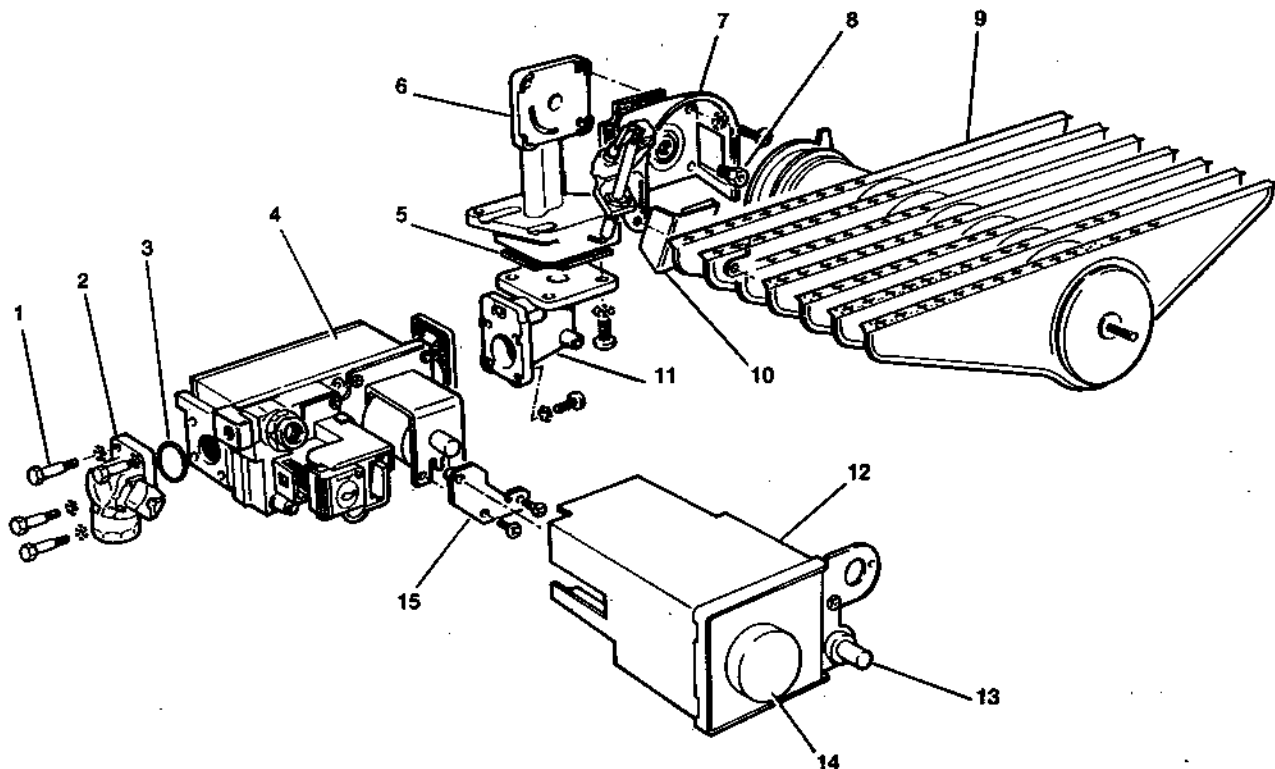

LEGEND

- | | | | |
|-----------------------|--------------------------------------|--------------------------|-----------------------------------|
| 1. Extended nuts. | 5. Sealing gasket. | 8. Main burner injector. | 12. Control box. |
| 2. Gas service cock. | 6. Burner manifold. | 9. Main burner. | 13. piezo unit. |
| 3. 'O' ring. | 7. Air box and pilot burner assembly | 10. Pilot burner shield. | 14. Boiler thermostat knob. |
| 4. Gas control valve. | | 11. Manifold extension. | 15. Control box mounting bracket. |

FAULT FINDING

Before attempting any electrical fault finding, ALWAYS carry out the preliminary electrical system checks as detailed in the Instructions for the British Gas Multimeter, or similar test meter.

Detailed instructions on the cleaning & adjustment or replacement of faulty components are contained in the 'Servicing' section of this publication.

25 PILOT WILL NOT LIGHT

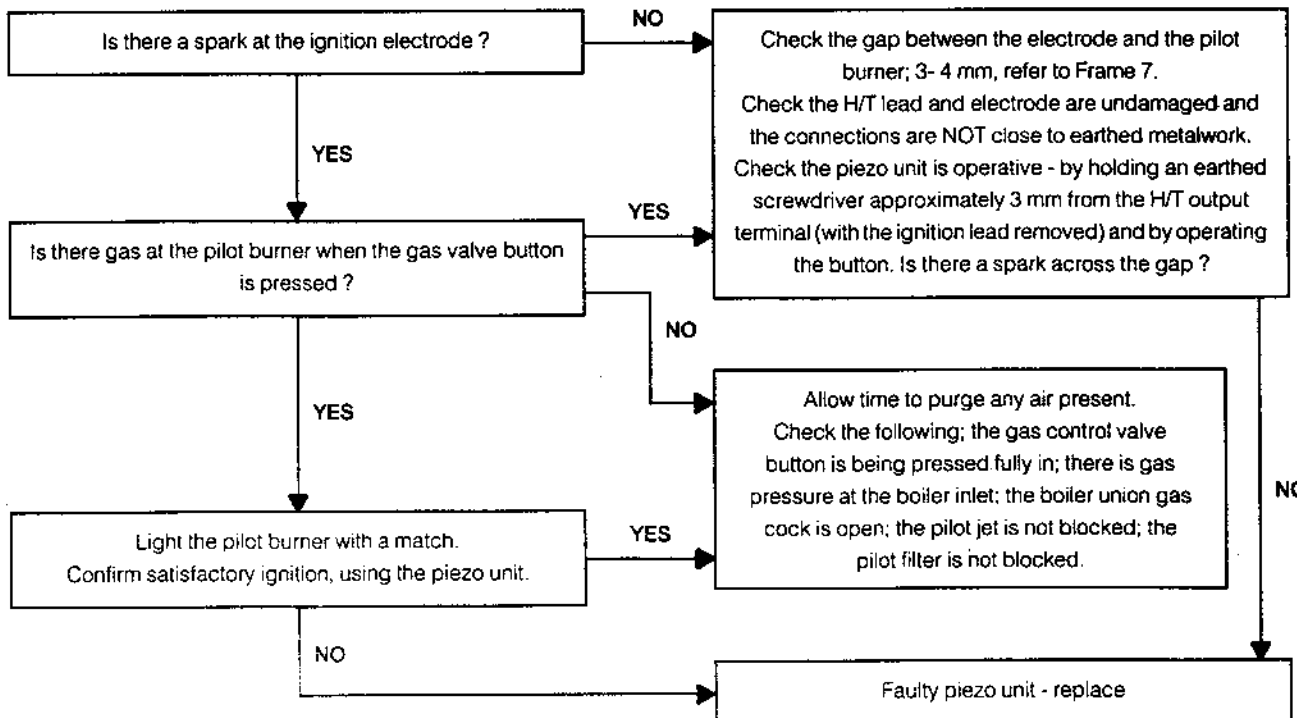

26 PILOT WILL NOT STAY LIT WHEN THE GAS VALVE BUTTON IS RELEASED

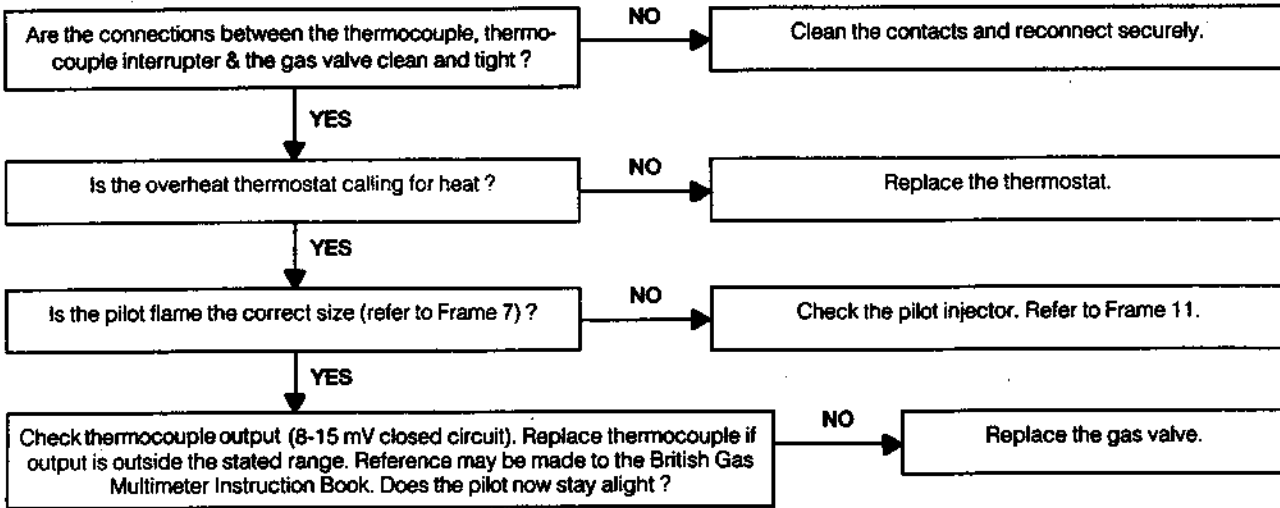

27 PILOT LIT BUT NO MAINS GAS

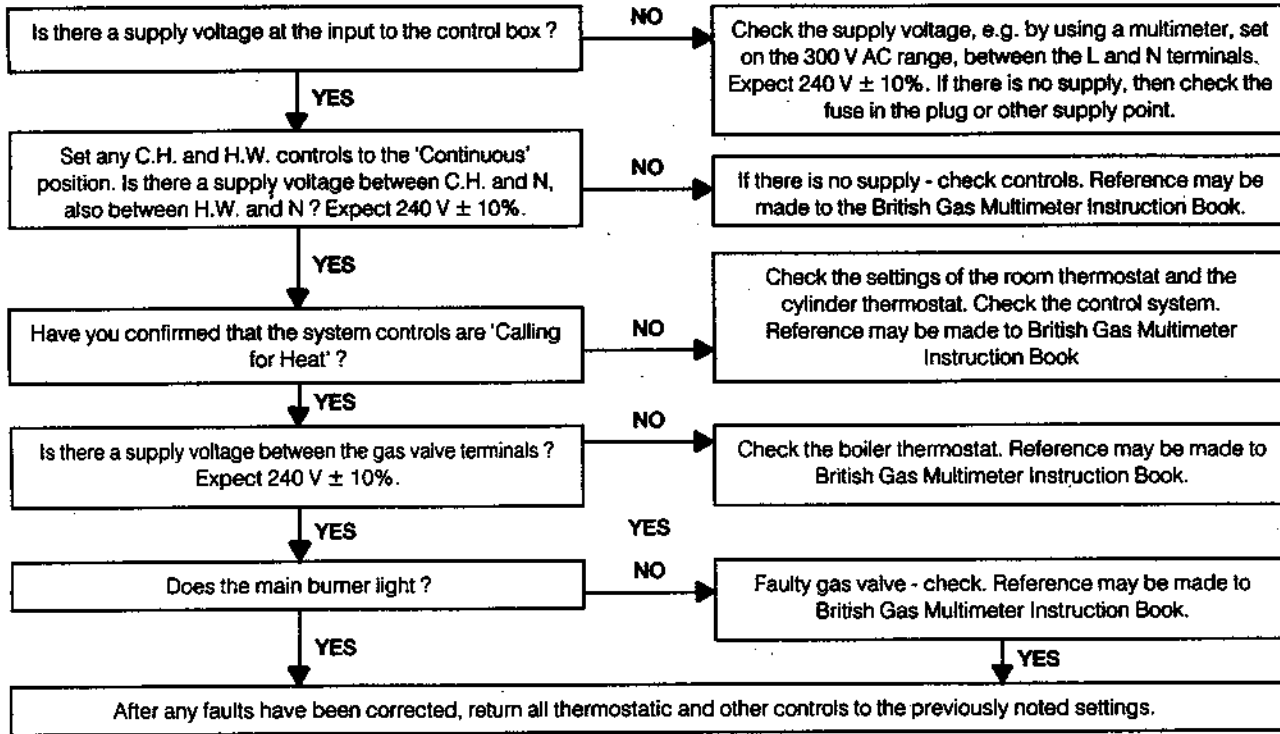

28 MAIN BURNER IS SHUT DOWN BY THE OVERHEAT THERMOSTAT

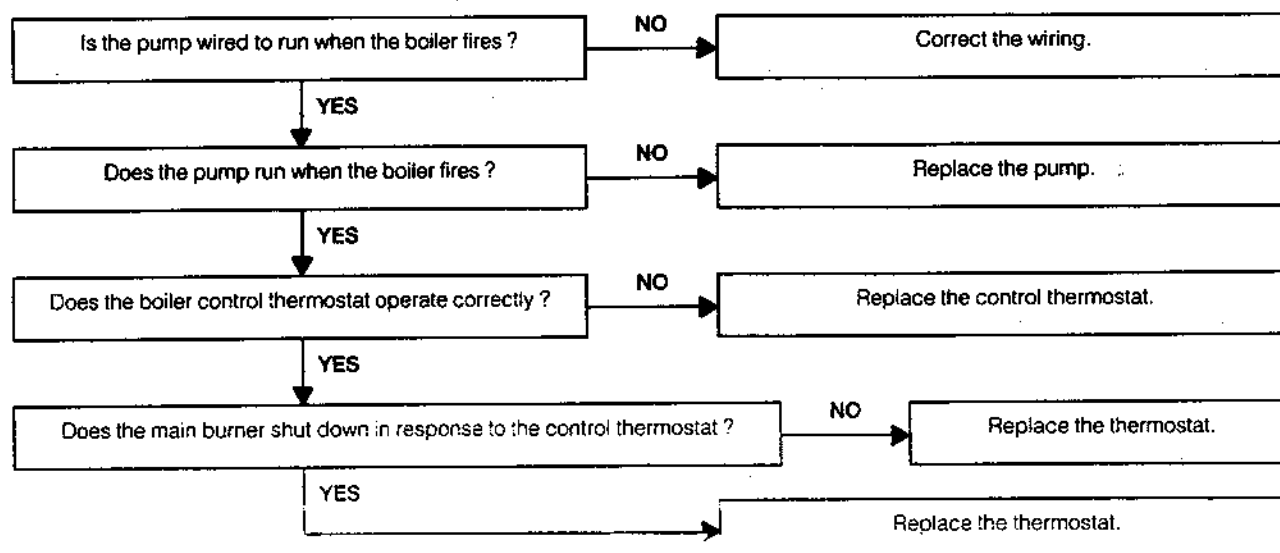

Ideal Elan 2 RS 230, RS 240, RS 250, RS 260 and RS 275 Gas Boilers.

The following list comprises parts commonly required as replacement components due to damage, expendability, or such that their failure or absence is likely to affect safety or performance. The list is extracted from the British Gas List of Parts, which contains all available spare parts.

Details of the British Gas Lists are held by Gas regions, CARADON Distributors and by Merchants.

When ordering spares please quote:

1. Boiler Model
2. Appliance G.C. Number
3. Description
4. Maker's Part Number
5. Quantity

Key No.	G.C. Part No.	Description	No. Off	Makers Part No.
3	319 493	Sightglass assembly kit.	1	160 079 333
6		Main burner.		
	386 232	AEROMATIC No. AC 19/123 275; RS 240	1	160 113 211
	386 235	AEROMATIC No. AC 19/123 278; RS 230	1	160 113 207
	386 233	AEROMATIC No. AC 19/123 276; RS 250 and RS 260	1	160 113 209
	386 234	AEROMATIC No. AC 19/123 277; RS 275	1	160 113 210
8		Main burner injector.		
	398 315	BRAY Cat. 16 - size 750; RS 230	1	169 110 435
	398 339	BRAY Cat. 16 - size 1100; RS 240	1	129 298 736
	398 329	BRAY Cat. 16 - size 1400; RS 250	1	189 746 060
	398 332	BRAY Cat. 16 - size 1700; RS 260	1	189 456 061
	398 064	BRAY Cat. 10 - size 2200; RS 275	1	189 776 060
9	308 347	Pilot burner. HONEYWELL Q 359 A 1124	1	589 614 085
10		Pilot burner injector.		
	386 131	HONEYWELL 45900421 - 001	1	589 624 084
12	308 348	Gas control valve. HONEYWELL V 4700 E 1072, 240 V	1	586 611 900
14	397 705	Piezo unit, VERNITRON 60080	1	589 830 086
15	308 317	Ignition electrode, VERNITRON No. 1414	1	589 614 088
16	390 131	Thermocouple, HONEYWELL Q 309 A 2846, 18 in. lg.	1	586 811 720
20	308 319	Control box, including thermostat, thermostat knob and suppressor assembly.	1	589 610 065
22	384 689	Suppressor assembly	1	589 040 030
23	386 139	Thermostat, FRANCO K 36 - L 1016 with 48 in. capillary	1	589 610 051
24	308 012	Thermostat knob	1	589 070 052
25	392 922	Overheat thermostat, THERMODISC with E.C.O. leads and HONEYWELL interrupter	1	589 220 074
26		Boiler casing assembly - white stove enamel, with sightglass, foil insulation & bottom panel (less glass fascia).		
	308 388	Ideal Elan 2 RS 230, RS 240, RS 250 & RS 260.	1	189 734 035
	308 398	Ideal Elan 2 RS 275.	1	189 774 035
27		Controls casing bottom panel.		
	308 229	Ideal Elan 2 RS 230, RS 240, RS 250 & RS 260.	1	189 730 080
	308 238	Ideal Elan 2 RS 275.	1	189 770 080
28		Glass fascia.		
	308 389	Ideal Elan 2 RS 230, RS 240, RS 250 & RS 260.	1	189 732 289
	308 390	Ideal Elan 2 RS 275.	1	189 772 289
31		Casing seal.		
	319 125	Ideal Elan 2 RS 230, RS 240, RS 250 & RS 260.	1	189 744 033.
	319 126	Ideal Elan 2 RS 275.	1	189 774 033

29 SHORT PARTS

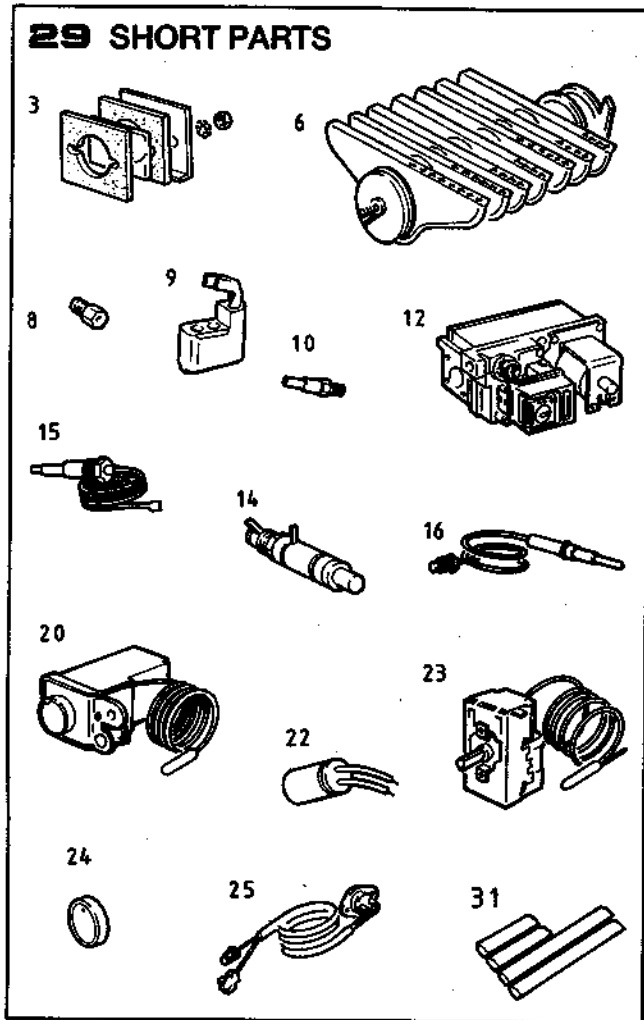

30 BOILER CASING ASSEMBLY

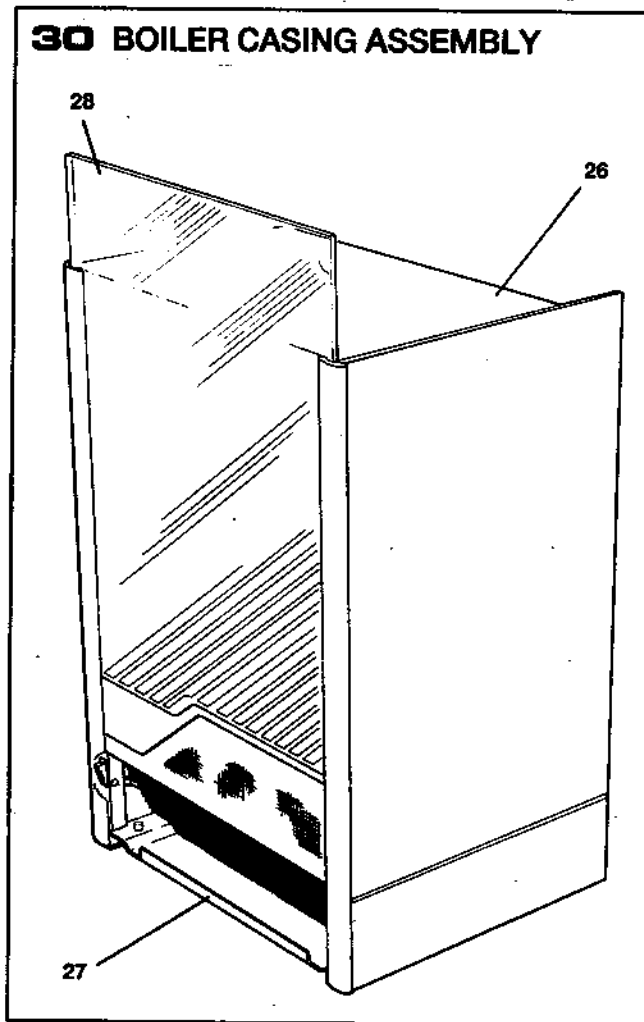

CARADON IDEAL Ltd. pursues a policy of continuing improvement in the design and performance of its products. The right is therefore reserved to vary specification without notice.

CARADON IDEAL Ltd,

P.O. Box 103, National Avenue,
Kingston upon Hull,
North Humberside. HU5 4JN.

Telephone: 01482 492 251 Fax: 01482 448 858.

Registration No. London 322 137.

Registered Office; National Avenue, Kingston upon Hull,
North Humberside, HU5 4JN.

A subsidiary of Caradon p.l.c

August 1994 101 267 A04



THIS SYMBOL IS YOUR ASSURANCE OF QUALITY

These appliances are designed for use with Natural Gas only. They have been tested and conform with the provisions of BS. 6332 and BS. 5258.

Products bearing this Kitemark are made to a safety and performance standard under a stringent scheme of supervision and control monitored by the British Standards Institute.