  
**Glow worm**  
 Instructions for Use  
 Installation and Servicing  
 To be left with the user

# Ultimate

## 60CF

G.C. No. 41 319 50

### Open Flue Boiler



This is a Cat I<sub>2H</sub> Appliance

Reference in these instructions to British Standards and Statutory Regulations/Requirements apply only to the United Kingdom.

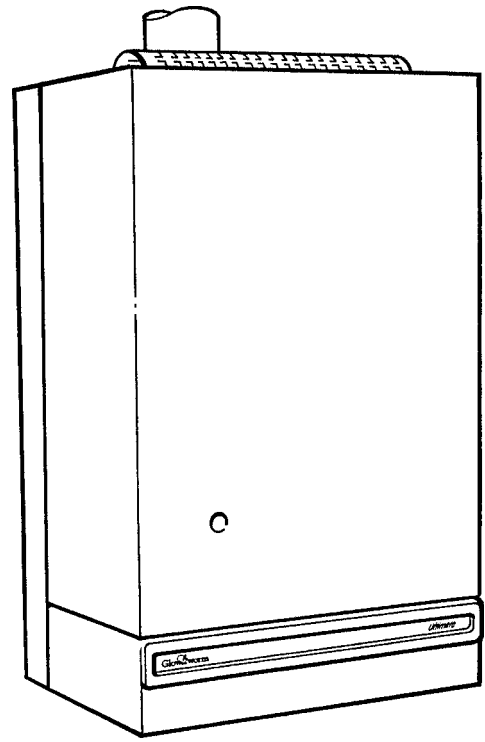

THIS DOCUMENT HAS BEEN PROVIDED BY  
  
 PLEASE VISIT [WWW.HEATINGSAPRES247.COM](http://WWW.HEATINGSAPRES247.COM) FOR FURTHER INFORMATION AND GENUINE PARTS & SPARES AT LOW PRICES

*The instructions consist of three parts, User, Installation and Servicing Instructions, which includes the Guarantee Registration Card. The instructions are an integral part of the appliance and must, to comply with the current issue of the Gas Safety (Installation and Use) Regulations, be handed to the user on completion of the installation.*

### Guarantee Registration

Thank you for installing a new Glow-worm appliance in your home.

Glow-worm appliances' are manufactured to the very highest standard so we are pleased to offer our customers' a Comprehensive First Year Guarantee.

Attached to the centre of these instructions is your Guarantee Registration Card, which we recommend you complete and return as soon as possible.

If this card is missing you can obtain a copy or record your registration by telephoning the Heatcall Customer Service number 01773 828100.

Our Guarantee gives you peace of mind plus valuable protection against breakdown by covering the cost of:

- All replacement parts**
- All labour charges**
- All call-out charges**

**REGISTER YOUR GLOW-WORM APPLIANCE  
 FOR 1ST YEAR GUARANTEE PROTECTION**

## CALL 0208 247 9857

**Customer Services:**  
 Tel: (01773) 828100  
**One Contact Local Service** Fax: (01773) 828070

**Hepworth Heating Ltd.,**  
 Nottingham Road, Belper, Derbyshire. DE56 1JT  
**General/Sales enquiries:**  
 Tel: (01773) 824141 Fax: (01773) 820569

## Important Information

### Testing and Certification

This boiler is tested and certificated for safety and performance. It is therefore important that no alteration is made to the boiler, without permission, in writing, from Hepworth Heating Ltd.

Any alteration not approved by Hepworth Heating Ltd., could invalidate the certification, boiler warranty and may also infringe the current issue of the Statutory Requirements, see Section 1.4.

### CE Mark

This boiler is exempt from the general requirements of the Boiler (Efficiency) Regulations (1993) and Directive 92/42/EEC by reason of its conformity to Schedule 3.1.7 of those Regulations and Article 4.3 of that Directive.

The CE mark on this appliance shows compliance with:

1. Directive 90/396/EEC on the approximation of the laws of the Member States relating to appliances burning gaseous fuels.
2. Directive 73/23/EEC on the harmonization of the Laws of the Member States relating to the electrical equipment designed for use within certain voltage limits.
3. Directive 89/336/EEC on the approximation of the Laws of the Member States relating to electromagnetic compatibility.

### INFORMATION FOR THE INSTALLER AND SERVICE ENGINEER.

Under Section 6 of The Health and Safety at Work Act 1974, we are required to provide information on substances hazardous to health.

#### CERAMIC FIBRE/INSULATION PADS, GLASSYARN.

These can cause irritation to skin, eyes and the respiratory tract. If you have a history of skin complaint you may be susceptible to irritation. High dust levels are usual only if the material is broken. Normal handling should not cause discomfort, but follow normal good hygiene and wash your hands before eating, drinking or going to the lavatory. If you do suffer irritation of the eyes or severe irritation to the skin seek medical attention.

#### THERMOSTATS

These contain very small amounts of xylene in the sealed phial and capillary. If broken, under normal circumstances the fluid does not cause a problem, but in case of skin contact, wash with cold water. If swallowed drink plenty of water and seek medical attention.

#### COMBUSTION PRODUCTS SAFETY DEVICE

These contain a very small amount of ethylene glycol and methanol in the capillary. If broken, under normal circumstances the fluid does not cause a problem, but in cases of skin or eye contact, wash with cold water. If ingested, drink plenty of water and seek medical attention.

CONTENTS	DESCRIPTION	SECTION	PAGE No.
<b>INSTRUCTIONS FOR USE</b>	Introduction		3
	Lighting the Boiler		4
<b>INSTALLATION INSTRUCTIONS</b>	General Data	1	5
	Flue & Ventilation	2	6
	Water Systems	3	7
	Installation	4	8
	Electrical Connection	5	10
	Commissioning	6	11
	User Information	7	13
<b>SERVICING INSTRUCTIONS</b>	Servicing and Replacement Parts	8	13
	Fault Finding	9	17
	Spare Parts	10	20

# Instructions for Use

## Introduction

Please read these instructions and follow them carefully for the safe and economical use of your boiler.

The Ultimate series are central heating boilers designed to provide heating and indirect domestic hot water.

## Important Notice

This boiler is for use only on natural gas G20.

## The Gas Safety (Installation and Use) Regulations

In your interests and that of gas safety it is the Law that ALL gas appliances are installed by competent person in accordance with the current issue of the above regulations.

## Gas Leak or Fault

If a gas leak or fault exists or is suspected, the BOILER MUST BE TURNED Off, including the electrical supply and MUST NOT BE USED UNTIL THE FAULT HAS BEEN PUT RIGHT. Advice/help should be obtained from your installation/servicing company or the local gas undertaking.

## Maintenance

To ensure the continued efficient and safe operation of the boiler it is recommended that it is checked and serviced as necessary at regular intervals. The frequency of servicing will depend upon the particular installation conditions and usage, but in general once a year should be enough.

If this appliance is installed in a rented property there is a duty of care imposed on the owner of the property by the current issue of the Gas Safety (Installation and Use) Regulations, Section 35.

It is the Law the any servicing be carried out by a competent person.

To obtain service, please call your installer or Heatcall (Glow-worm's own service organisation) using the telephone number given on the control tray.

Please be advised that the 'Benchmark' logbook should be completed by the installation engineer on completion of commissioning and servicing.

All CORGI Registered Installers carry a CORGI ID card, and have a registration number. Both should be recorded in your boiler Logbook. You can check your installer is CORGI registered by calling CORGI direct on :- 01256 372300.

## Boiler Clearances

If fixtures are positioned close to the boiler space must be left as shown in diagram 1. Enough space must also be left in front of the boiler to allow for servicing.

The convection air openings on top of the boiler must never obstructed.

### Boiler Installed in a Compartment or Cupboard

If the boiler is installed in a compartment or cupboard do not obstruct any ventilation openings.

Do not use the compartment or cupboard for storage.

## Cleaning

**WARNING.** This appliance contains metal parts (components) and care should be taken when handling and cleaning, with particular regard to edges.

Clean the casing occasionally by wiping it over with a damp soapy cloth or dry polishing duster.

Do not use an abrasive cleaner.

## Boiler Electrical Supply

**Warning.** This boiler must be earthed.

The boiler must be connected to a 230V~50Hz supply, protected by a 3A fuse.

All wiring must be in accordance with the current issue of BS7671.

Cables, PVC insulated type, to the current issue of BS6500 Table 16, 0.75mm<sup>2</sup> (24/0.20mm) only may be used to connect the boiler up.

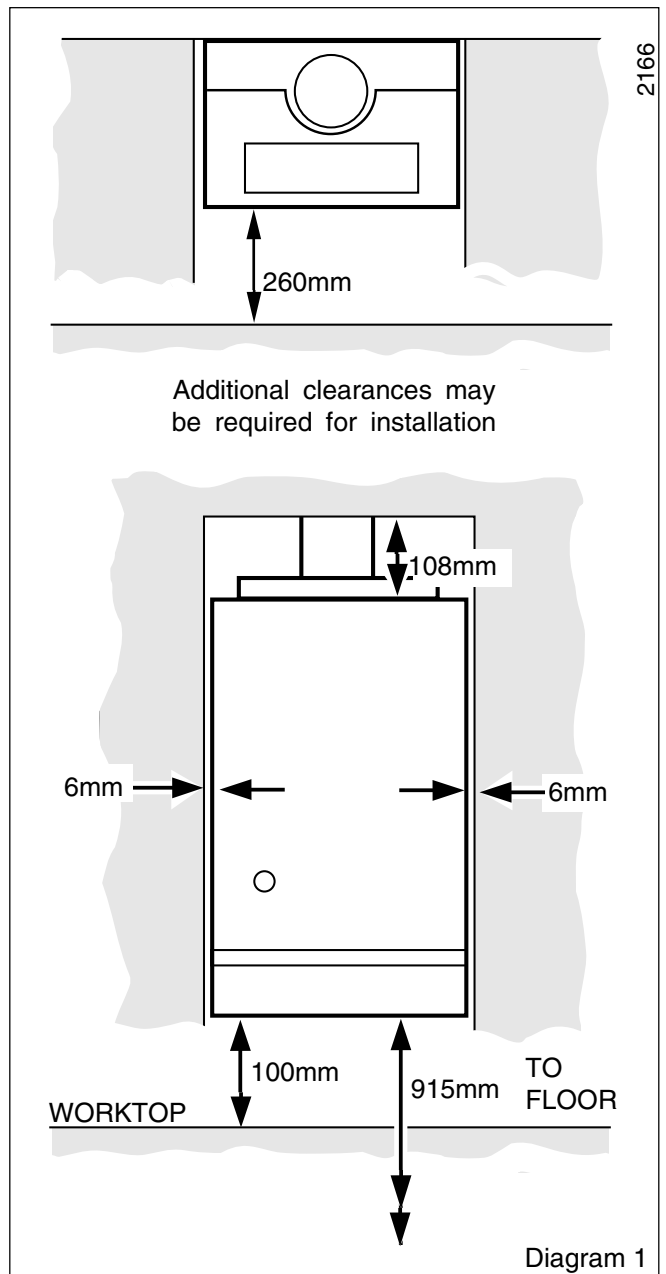

# Instructions for Use

## Connecting an Electrical Plug

The colours of three core flexible cable are, Brown - live, Blue - neutral, Green and Yellow - earth.

As the marking on your plug may not correspond with these colours continue as follows:

The wire coloured brown must be connected to the terminal marked "L" or Red.

The wire coloured blue must be connected to the terminal marked "N" or Black.

The wire coloured green and yellow must be connected to the terminal marked "E" or Green or the earth symbol  $\perp$ .

## Safety Device

The boiler is fitted with a flue blockage safety device which will shut it down if there is a problem with the chimney. This device is NOT a substitute for an independently mounted Carbon Monoxide detector.

The safety device is reset, after three minutes, by pushing in the button shown in diagram 2.

Shut down can occur during certain climate conditioned, but if it recurs the chimney flue and air inlet into the room must be checked and any problems found corrected by a competent person, before the boiler is used again.

Any problems found must be put right, by a competent person, before the boiler is used again.

## To Turn the Boiler On

Turn the electrical supply on to the boiler and check that any remote controls are set to your requirements (refer to manufacturer's instructions supplied with these items).

**WARNING.** If the pilot flame goes out either intentionally or by accident, no attempt should be made to relight it for at least three minutes.

Slide to controls cover off and clear.

Identify the controls by reference to diagram 2.

Switch off the electrical supply to the boiler.

Check that the flue blockage safety device has not operated, that is, the button is in. Refer to Safety Device instructions.

Turn thermostat knob "B" faulty anticlockwise to the "O" Off position.

Push in control knob "D", keep pushed in, push and release piezo button "A" until the pilot lights.

Look through window "E".

After the pilot burner lights keep the button pushed in for about 20 seconds. Check that the pilot is alight and stable, look through window "E". If the pilot burner fails to stay alight, wait 3 minutes before repeating the lighting operation.

The safety device may also need resetting, refer to the instructions above.

The flue blockage safety device may also need resetting, refer to instructions above.

Turn thermostat control knob "B" to a setting between "MIN" and "MAX" and the main burner will light.

"MAX" is about 82°C (180°F).

The above sequence must be carried out every time that the burner is relit.

Check that all external controls are calling for heat.

## To Turn the Boiler Off

For short periods, turn the thermostat knob fully clockwise to "O" Off. To relight, turn thermostat knob anticlockwise to any position between "MIN" and "MAX".

For longer periods, turn the thermostat knob fully clockwise to "O" Off. Slide the gas control button "D" inward and release, see diagram 2. Switch off the electrical supply to the boiler.

To relight, follow the full lighting sequence given above.

## Protection Against Freezing

If the boiler is to be out of use for any long period of time during severe weather condition we recommend that the whole system, including the boiler, be drained off to avoid the risk of freezing up. Make sure that, if fitted, the immersion heater in the cylinder is switched off.

The serial number and GC number of the boiler can be found on the data label.

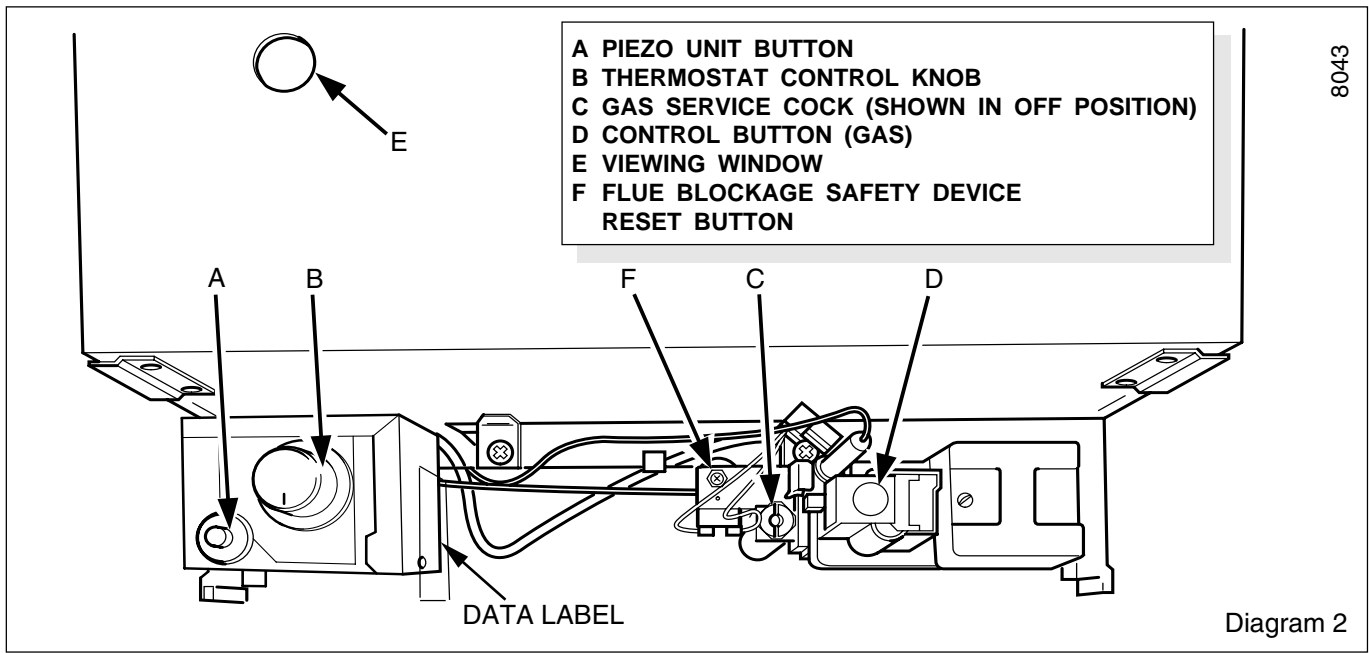
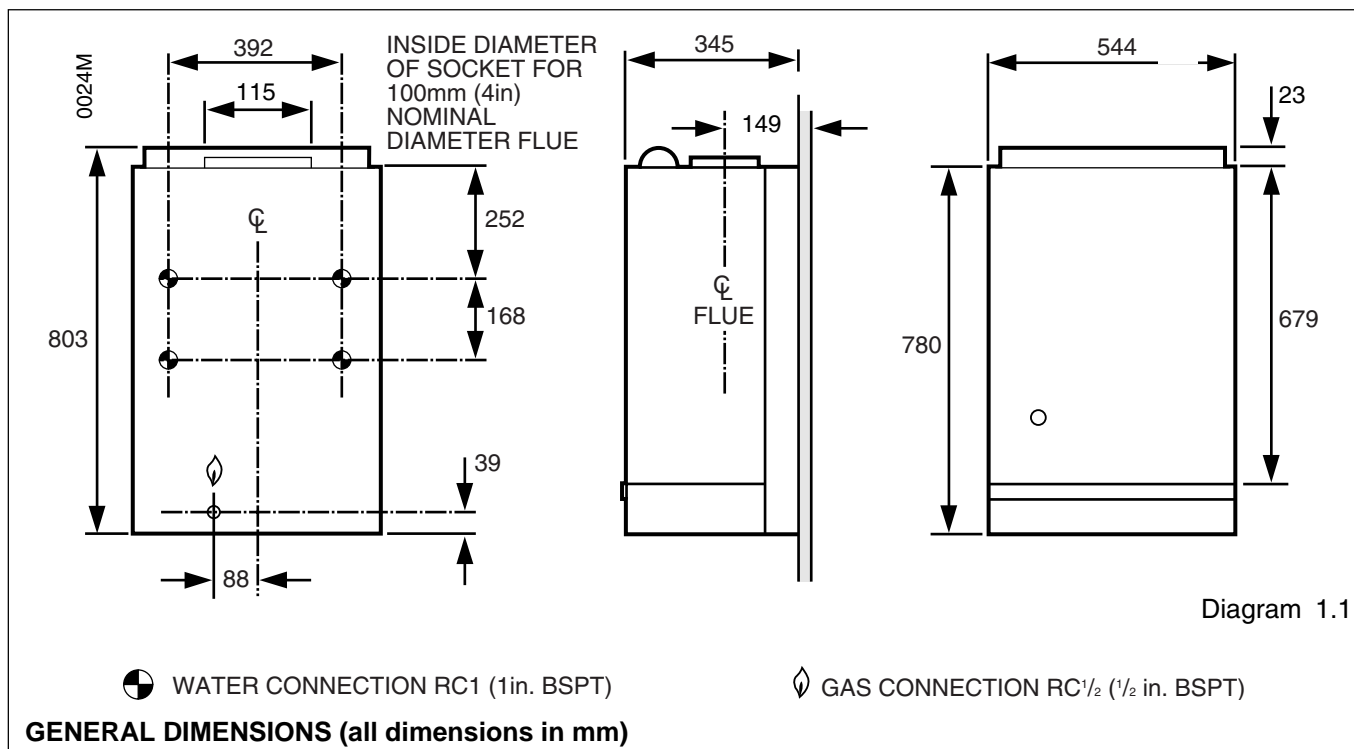

Diagram 2

## 1 General Data



### 1 General Notes and Information

This boiler is for use on natural gas G20.

Wherever possible, all materials, appliances and components to be used shall comply with the requirements of applicable British Standards.

Where no British Standard exists, materials and equipment should be fit for their purpose and of suitable quality and workmanship.

This boiler is not suitable for use out of doors.

### Sheet Metal Parts

**WARNING.** When installing or servicing the boiler care should be taken when handling sheet metal parts, to avoid any possibility of personal injury.

### 1.1 Statutory Requirements

The installation of the boiler must be carried out by a competent person in accordance with the relevant requirements of the current issue of:

Manufacturer's instructions, supplied.

The Gas Safety (Installation and Use) Regulations,

The Building Regulations, Local Water Company Byelaws, The Building Standards (Scotland) Regulations (applicable in Scotland), The Health and Safety at Work Act, Control of Substances Hazardous to Health, The Electricity at Work Regulations and any applicable local regulations.

Detailed recommendations are contained in the current issue of the following British Standards and Codes of Practice:

BS6798, BS5440 Parts 1 and 2, BS5546 Part 1, BS5449, BS6891, BS7478, BS7593, BS7671.

Manufacturer's instructions must not be taken as overriding statutory requirements.

### 1.3 Range Rating

The boiler is range rated and may be adjusted to suit the individual system requirements.

The respective Table 1 gives the ratings and settings.

### 1.4 BSI Certification

The boiler is certificated to the current issue of BS6332 Part 1, invoking the current issue of BS5258 Part 1 for performance and safety. It is, therefore, important that no alteration is made to the boiler without permission, in writing, from Hepworth Heating Ltd.

Any alteration that is not approved by Hepworth Heating Ltd., could invalidate the BSI Certification of the boiler, warranty and could also infringe the current issue of the Statutory Requirements.

### 1.5 Gas Supply

The gas installation shall be in accordance with the current issue of BS6891.

The supply from the governed meter must be of adequate size to provide a steady inlet working pressure of 20mbar (8in wg) at the boiler.

On completion test the gas installation for soundness using the pressure drop method and suitable leak detection fluid, purge in accordance with the above Standard.

1.2 Data	
<b>Weight:</b>	70.5kg
<b>Water content:</b>	7.5litre
<b>Gas connection:</b>	Rc <sup>1</sup> / <sub>2</sub>
<b>Water connections:</b>	Rc1
<b>Electrical supply:</b>	230V~ 50Hz - fused at 3A
<b>Data label:</b>	On right hand side of electrical control box

# 1 General Data

## 1.6 Electrical Supply

**WARNING:** This boiler must be earthed.

All system components shall be of an approved type and shall be connected in accordance with the current issue of BS7671 and any applicable local regulations.

Connection of the boiler and system controls to the mains supply should be through a common isolator fused at 3A, maximum. This method of connection should be by a switched spur box with a minimum contact separation of 3mm in both poles. It should be clearly marked, showing its purpose, preferably positioned close to the boiler.

Alternatively an unswitched socket outlet and three pin plug, fused 3A, to the current issue of BS1363 may be used.

Wiring to the boiler must be PVC insulated cable at least 0.75mm<sup>2</sup> (24/0.20mm) to the current issue of BS6500 Table 16.

## 1.7 Contents of Packaging

The boiler is delivered in one pack which contains:

Boiler with outer case and wall frame, side panels, burner, combustion chamber shield, flueway baffle and loose items pack.

## 1.8 Water System

The boiler shall only be used on an unrestricted open vented system with the water supply taken from a feed and expansion tank, having a head between 1m (3ft 3in) minimum and 27m (90ft) maximum.

## 1.9 Draining Tap

A draining tap must be provided at the lowest point of the system which will allow the entire system, the boiler and hot water cylinder to be drained.

Draining taps shall be to the current issue of BS2879.

## 1.10 Safety Valve

A safety valve need not be fitted to an open vented system.

## 1.11 Location

**WARNING.** Open flue boilers must not be installed in a private garage.

The boiler must not be installed in a room used or intended to be used as sleeping accommodation or a room containing a bath or shower.

The boiler must be mounted on a flat wall which is sufficiently robust to take its weight.

## 1.12 Boiler Clearances

Refer to diagram 1. Instructions for Use.

The boiler must be positioned so that at least the minimum operational and servicing clearances are provided.

Additional clearances may be required for installation.

If fixtures are positioned next to the boiler they should be made removable for access to pipework.

Sufficient clearance must be left in front of the boiler for servicing.

## 1.13 Heating System Controls

The heating system should have installed: a programmer and room thermostat controlling the boiler.

Thermostatic radiator valves may be installed in addition to the room thermostat.

Note: For further information, see The Building Regulations 1991 - Conservation of fuel and power, 1995 edition - Appendix G, table 4b.

**TABLE 1**

ULTIMATE 60CF RANGE RATING			
RANGE RATING		Min.	Max.
NOMINAL HEAT INPUT (GROSS)	<i>kW</i> <i>Btu/h</i>	17.7 60,400	23.13 78,900
NOMINAL HEAT OUTPUT	<i>kW</i> <i>Btu/h</i>	13.19 45,000	17.59 60,000
BURNER SETTING PRESSURE	<i>mbar</i> <i>in.w.g</i>	7.5 3.0	13.0 5.2
APPROX. GAS RATE	<i>m<sup>3</sup>/h</i> <i>ft<sup>3</sup>/h</i>	1.71 60	2.25 79
INJECTOR MARKING	BURNER :- K8277 PILOT :- 7215		

# 2 Flue and Ventilation

## Important Note

The boiler is fitted with a Flue Blockage Safety Device, which will shut down the boiler if there is an unacceptable spillage of products at the draught diverter.

This safety device **MUST NOT** under any circumstances be interfered with or put out of action.

The safety device must only be replaced with the Glow-worm parts.

## 2.1 Flue Connection

The integral draught diverter makes the combustion performance independent of conditions in the secondary flue, but an efficient flue is necessary to ensure a trouble free installation.

COMPARTMENT AIR VENT TABLE 2.				
ULTIMATE 60CF				
COMPARTMENT VENTILATION REQUIREMENTS	HIGH LEVEL VENT AREA		LOW LEVEL VENT AREA	
FROM ROOM OR SPACE	208cm <sup>2</sup>	32in <sup>2</sup>	416cm <sup>2</sup>	64in <sup>2</sup>
FROM OUTSIDE	104cm <sup>2</sup>	16in <sup>2</sup>	208cm <sup>2</sup>	32in <sup>2</sup>

## 2 Flue and Ventilation

The flue must be installed in accordance with the recommendations in the current issue of BS5440 Part 1.

The flue should be kept as short as possible.

Horizontal or very shallow runs should be avoided.

Give maximum possible vertical rise from the boiler, minimum 600mm (24in) before any bend.

The use of 45° bends is recommended.

A slip-on loose collar must be provided for flue removal.

End with a certificated terminal, above ridge height, if possible, if not, at least above the eaves of a pitched roof.

A previously used chimney must be swept and any register plate or damper or the like must be removed or locked in the open position and the chimney made good.

### 2.2 Boilers in a Compartment

Where the installation of the boiler will be in an unusual location, special procedures are necessary. Refer to the current issue of BS6798 for guidance.

A compartment used to enclose the boiler must be designed and constructed specifically for this purpose.

An existing cupboard or compartment modified for the purpose may be used. Refer to the current issue of BS6798 for guidance.

The doorway opening should be of sufficient size to allow for easy removal of the boiler.

Be provided with permanent ventilation openings as shown in the respective Table 2. These figures are for the minimum free area.

The high and low level openings must communicate with the same room or space or must both be on the same wall to outside air.

The compartment door or vent should not communicate with a private garage, bedroom, bed sitting room or a room containing a bath or shower.

### 2.2A Boilers in a Room or Space

A purpose designed ventilation opening must be provided on an outside wall of the building, this opening may be either, directly into the room or space containing the boiler, or into an adjacent room or space which has an internal permanent air vent of the same size to the room containing the boiler.

Do not ventilate through a kitchen, private garage, bathroom or toilet.

Vents through a cavity wall must be ducted.

If there are other fuel burning appliances present, allowance must be made for their combustion requirements. The free area for the boiler is:

60CF - 73cm<sup>2</sup> (11in<sup>2</sup>)

Refer also to the current issue of BS5440 Part 2.

### 2.3 Products of Combustion

Test the boiler for clearance of flue products at the draught diverter as detailed in the current issue of BS5440 Part 1.

### 2.4 Extract Fans

If an extract fan is fitted there is a possibility that if adequate air is not provided spillage of the flue products could occur. If vents are fitted in accordance with the above recommendations this should not occur.

Where such an installation is found a spillage test must be carried out as detailed in the current issue of BS5440 Part 1 and any necessary action taken.

### 2.5 Timber Frame Buildings

If the boiler is to be installed in a timber frame building it should be fitted in accordance with the Institute of Gas Engineers document IGE/UP/7/1998. If in doubt seek advice from the local gas undertaking or Hepworth Heating Ltd.

## 3 Water Systems

### Frost Protection

If the position of the boiler is such that it may be vulnerable to freezing it should be protected as specified in the current issue of BS5422. It is also recommended that a frost protection thermostat be fitted.

### 3.1 Cylinders

For all systems supplying domestic hot water the cylinder must be indirect. It is recommended that the cylinder be fitted with some form of temperature control.

### 3.2 Gravity Domestic Hot Water with Pumped Heating

It is important that the flow and return connections are in the same relative positions as shown in diagram 3.1.

The domestic flow and return must both be on one side of the heat exchanger. The heating flow and return are taken from the other.

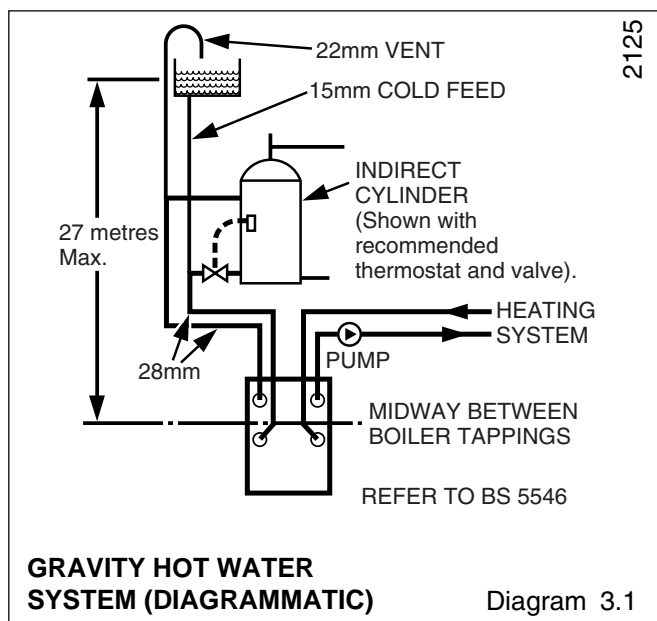

## 3 Water Systems

### 3.3 Pumped Heating and Hot Water

It is important the flow and return connections are made as shown in diagram 3.2.

These connections may be fitted on the opposite side to that shown but always in the same relative positions.

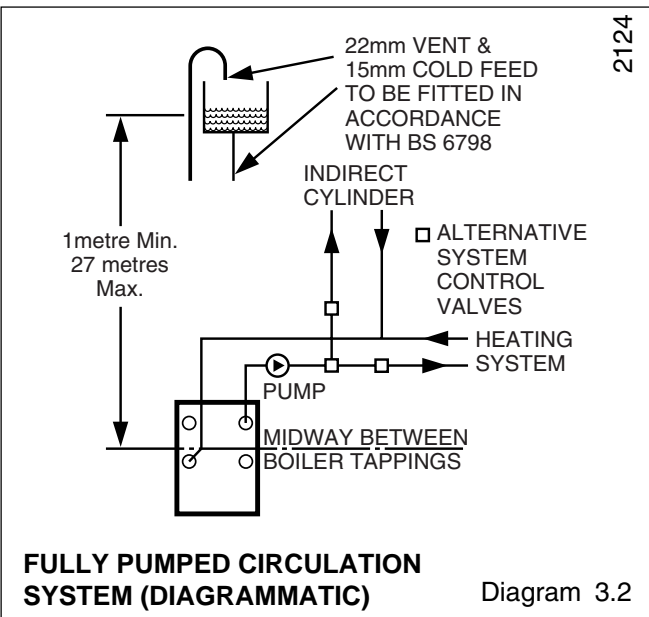

### 3.4 Pump

This should be fitted on the flow pipe and have isolating valves fitted each side, integral, if possible.

The pump should be set to give a temperature difference of 11°C (20°F) between flow and return, with the boiler thermostat set at "MAX" which is about 82°C (180°F).

The resistance through the boiler can be found from diagram 3.3.

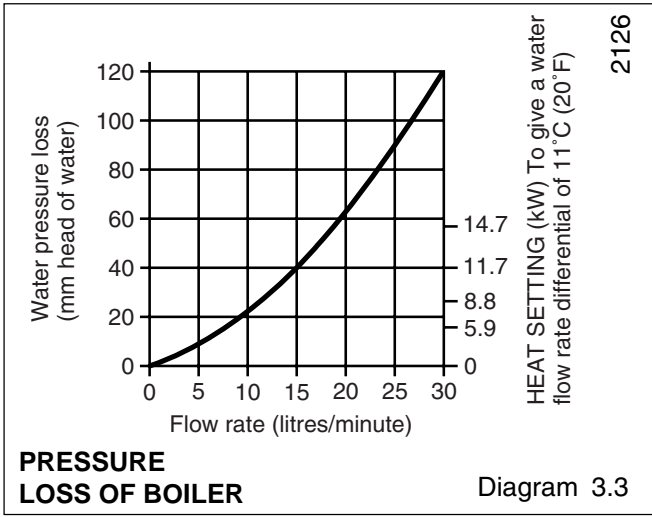

## 4 Installation

### 4.1 Unpacking

Unpack and check that the contents, listed below, are present and undamaged:-

Boiler, combustion chamber shield, side panels x 2, burner, flueway baffle, loose items pack (with check list).

With the boiler still in the bottom tray, slide the controls cover upwards and remove as shown in diagram 4.1. Remove the outer case by undoing, and retaining, the two screws and lifting off, see diagram 4.1.

Release the wall frame by removing and keeping the two retaining screws at the back of the combustion chamber, see diagram 4.2.

To remove the boiler, turn it over, sideways, out of the bottom tray, see diagram 4.3, taking care not to damage the controls, so that it is face down on the floor, exposing the four Rc1 (1in BSP) water connections.

Remove the remaining loose items, including the wall frame which is in the bottom of the tray.

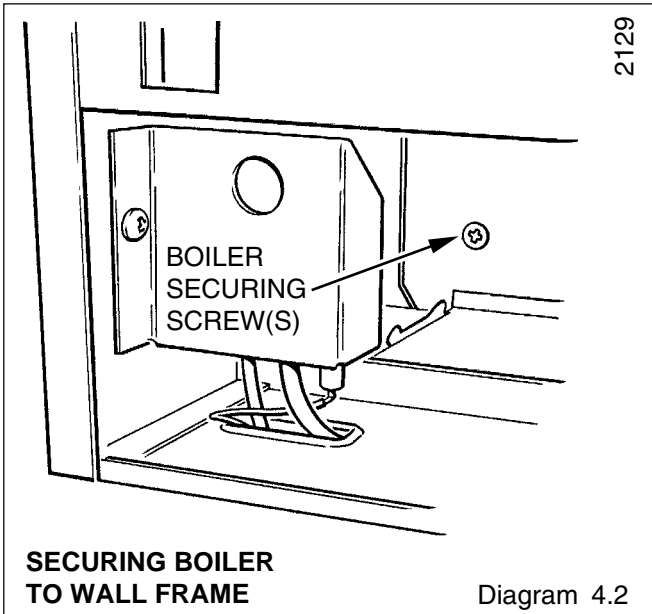
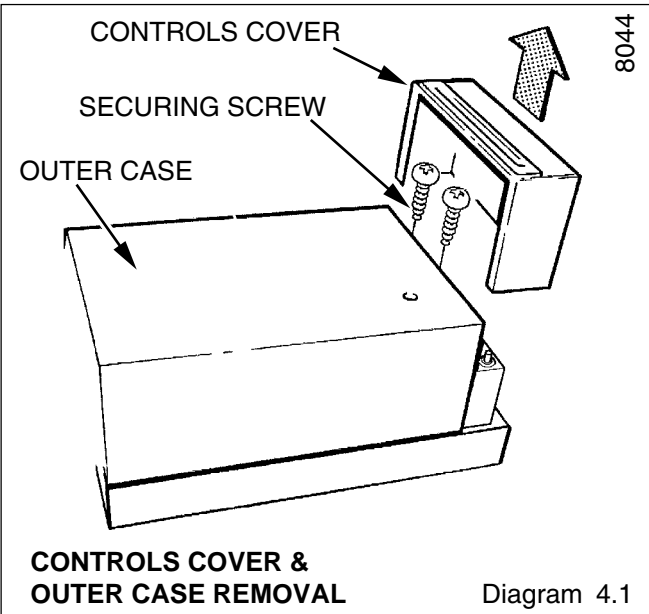

## 4 Installation

Note: It is NOT recommended that the boiler be placed in an upright position. If it is unavoidable great care must be taken not to damage the gas valve, to avoid this it is suggested that support be placed under the boiler, positioned as shown in diagram 4.3.

### 4.2 Preparation

Use the wall frame and refer to diagram 4.4, mark out the position of the fixing holes, making sure they are square.

Remove the wall frame and drill holes to suit plugs and screws provided. Secure the wall frame with its cross member at the top, to the wall.

Make sure the wall frame is level.

Fit suitable Rc1 (1in BSP) fittings into the appropriate tappings. Tighten to required position and then fit suitable fittings and short lengths of pipe into these fittings, making sure that they will be in an accessible position when the boiler is fixed.

Note: It is important to make sure that all these joints are watertight at this stage as they will not be directly accessible after the boiler is fixed.

### 4.3 Mounting the Boiler

Note: Access to the screw holes is through the combustion chamber, see diagram 4.3. Take care not to damage the pilot and thermocouple assembly.

Lift the boiler and position on to the wall frame so that the tags on the boiler body locate on the cross member of the wallframe, see diagram 4.5. Fasten the boiler to the wallframe, using the screws previously removed.

Remove the flue cleaning door, see diagram 4.6.

Remove the split pin. Withdraw the retaining angle and thermostat phial from its pocket.

Fit the flueway baffle, making sure that it is seated down correctly onto the casing as shown in diagram 4.6.

Re-assembly note: When fitting the thermostat, make sure that the thermostat is fully inserted into the phial pocket and then insert the retaining angle.

Replace the flue cleaning door.

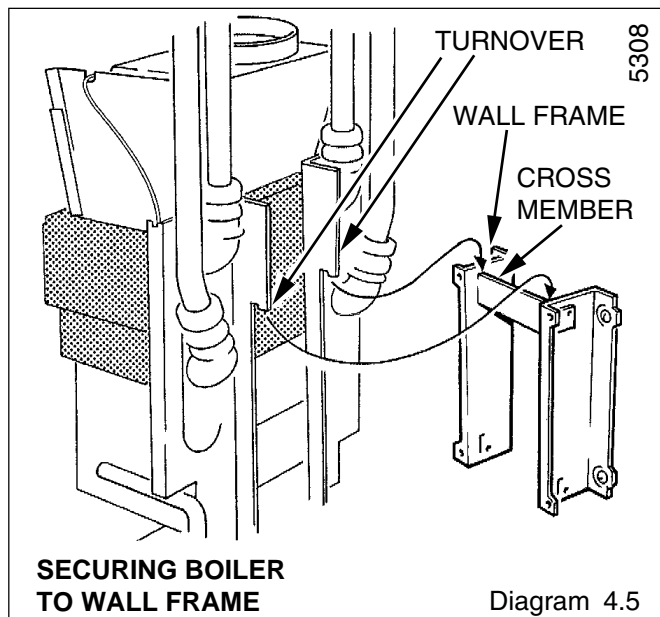
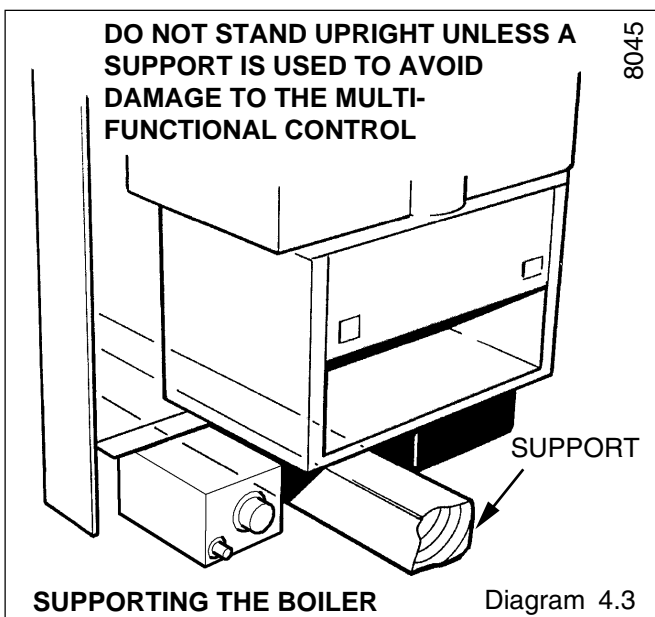
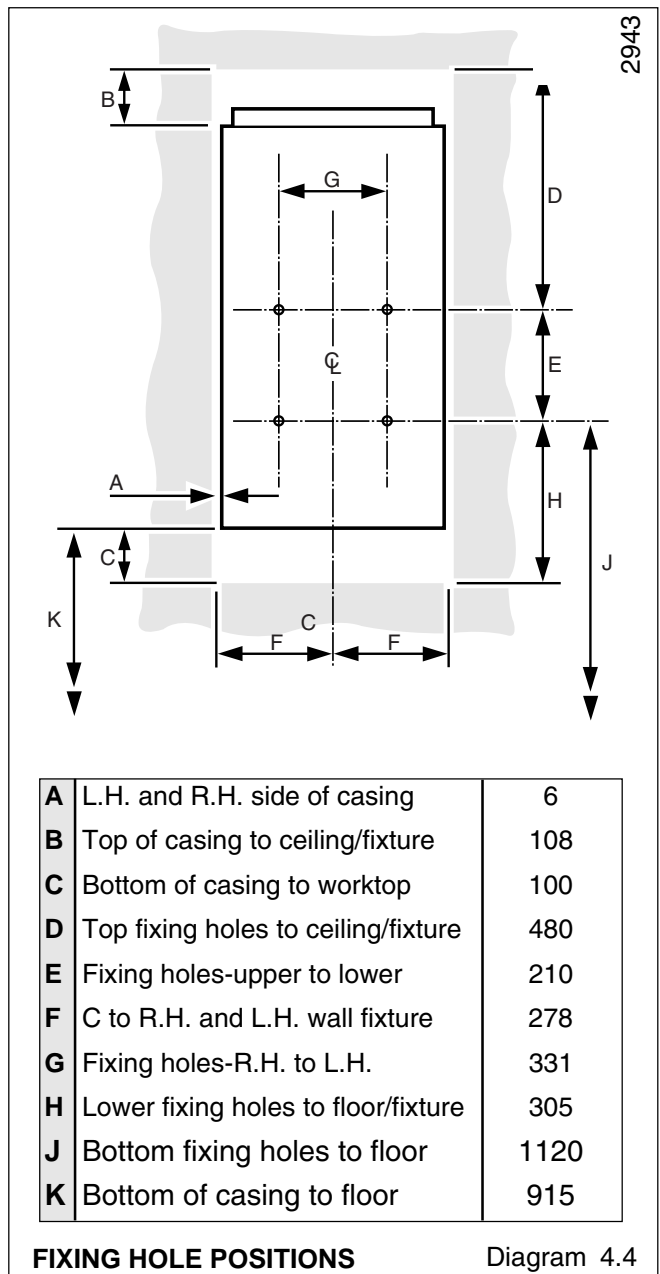

## 4 Installation

### 4.4 Water Circulation System

Complete the water connections to the boiler pipework, using compression fittings.

Fill, vent and cold flush the system as recommended in the current issue of BS6798.

Visually check for and put right any water leaks.

### 4.5 Gas Connection

Make the gas connection to the flanged Rc<sup>1</sup>/<sub>2</sub> gas service cock.

### 4.6 Flue

Install the flue pipework and seal to the flue socket in accordance with normal practice.

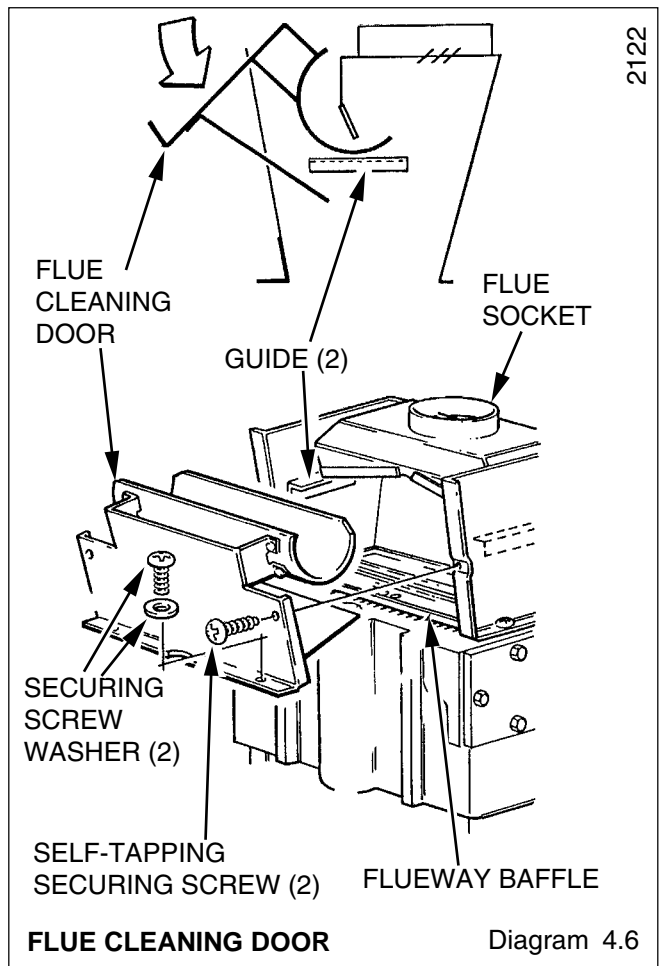

## 5 Electrical Connection

### 5.1 Control Box Removal

Remove the electrical control box securing screw, see diagram 5.1. Pull the control box down at the front and pull forwards to release from hook at rear, see diagram 5.2.

### 5.2 Cable Connection

Thread the power supply cord through the clamp at the rear of the control box, as shown in diagram 5.2.

The earth conductor must be made of a greater length so that if the cable is strained the earth conductor is the last to become disconnected.

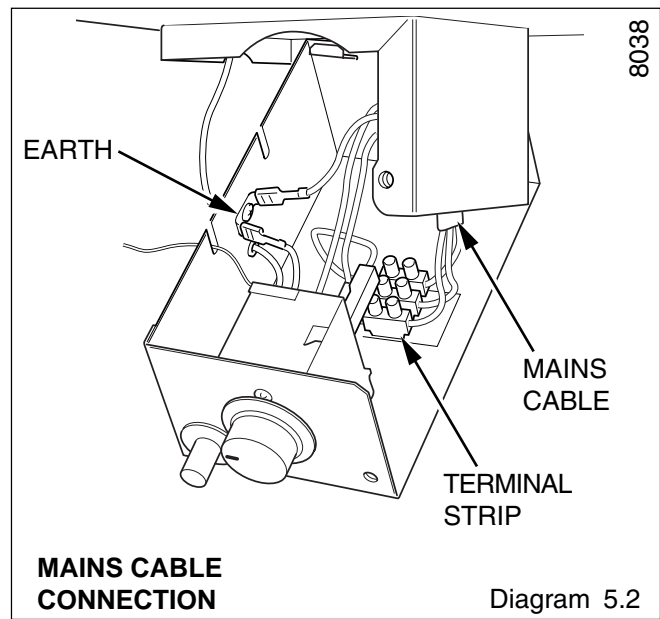
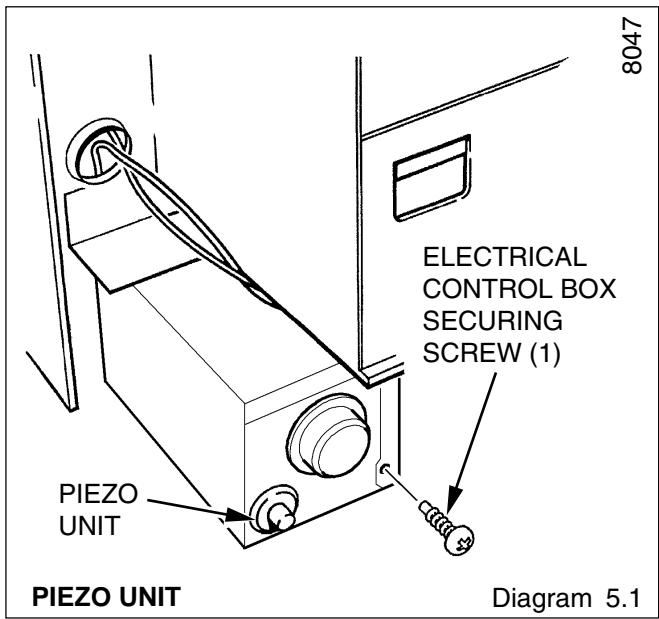

## 5 Electrical Connection

Connect to the terminal strip, as shown in diagram 5.3.

Secure the cable into the clamp, as shown in diagram 5.2.

Make sure that there is sufficient cable to allow the control box to be temporarily hooked into the front slot, to allow for servicing.

Replace the control box by reversing the information given above in Section 5.1. Take care not to trap the thermostat capillary at the rear of the control box also make sure the rear location hook is correctly engaged.

### 5.3 Testing

Checks to ensure electrical safety should be carried out by a competent person.

It is essential that the polarity is correct.

In the event of an electrical fault after installation of the system, the preliminary electrical system checks, as below should be carried out:

1. Test insulation resistance to earth of mains cable.
2. Test earth continuity and short circuit of all cables.
3. Switch on the electrical supply to the boiler and test the polarity of the mains supply.

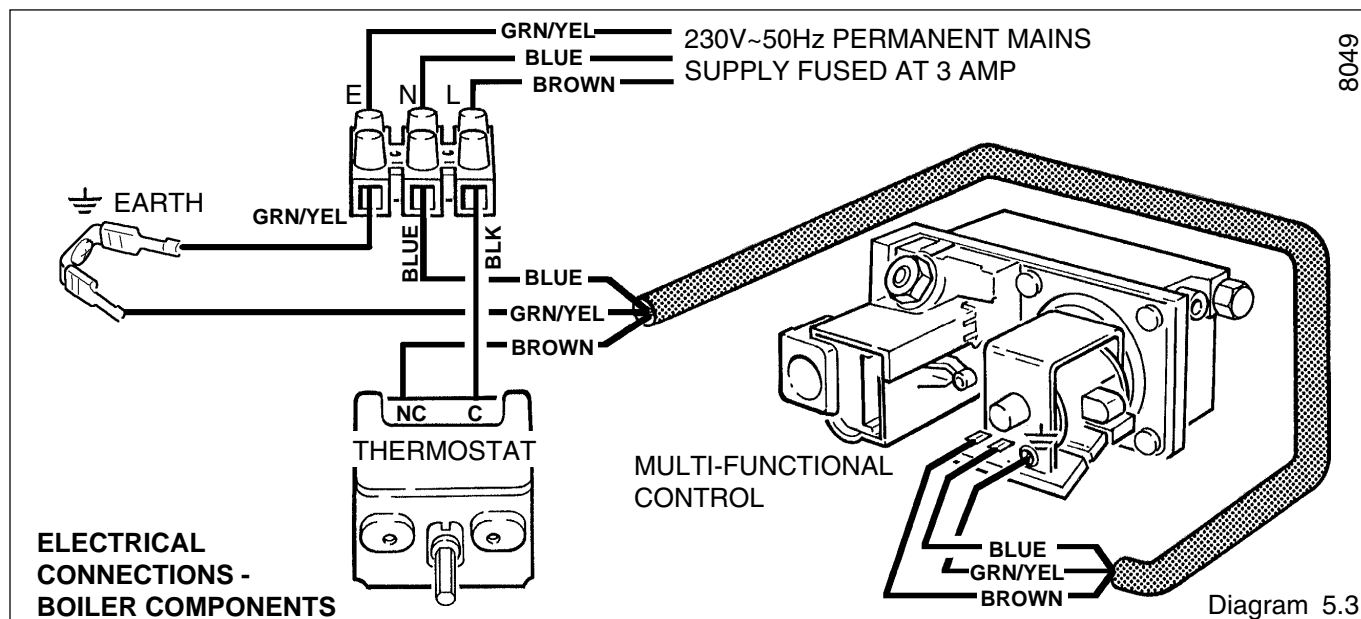

## 6 Commissioning

Please ensure the "Benchmark" logbook is completed and left with the user.

### 6.1 Testing, Initial Lighting and Adjustment

Make sure that all naked lights, pipes and cigarettes are out.

Pressure test the complete installation for soundness and purge in accordance with the current issue of BS6891.

Refer to diagram 6.1 to fit the burner.

Identify the controls by reference to diagram 6.2.

Check that the gas service cock "C" is off, that is, indicator vertical.

Check that the mains electrical supply to the boiler is off.

Set the thermostat control knob "B" to "O" - the off position.

Remove the gas pressure test nipple screw "E" and fit a suitable pressure gauge.

Open gas service cock "C".

Note. Make sure that the flue blockage safety device reset button "P" is fully pushed in.

Push in control button "K", keep pressed in and at the same time operate the piezo unit button "G" until the pilot burner lights.

After the pilot burner lights keep the button "K" pushed in for about 15 seconds. If the pilot burner fails to light or stay alight a safety device in the multifunctional control prevents immediate re-lighting.

Do not attempt to relight until the safety device has reset, that is, after a minimum of 3 minutes.

Note. Should the boiler fail to operate correctly refer to Fault Finding Section.

Check the length of the pilot flame, it should envelop the thermocouple tip as shown in diagram 6.3. The pilot rate can be adjusted, if necessary, by turning the pilot burner adjustment screw "N", having first removed the multifunctional control cover by releasing the screw as diagram 6.4.

Test pilot supply connections for gas soundness, using a suitable leak detection fluid.

Hook the combustion chamber shield onto the front of the combustion chamber, making sure that it is flush and horizontal with the combustion chamber front, see diagram 6.1.

Fit the outer case, making sure that the lower part clears the pilot supply tube. Secure with the screws previously removed.

Make sure that the pilot is alight and stable by viewing through the window in the casing.

Switch on the electrical supply to the boiler and turn on all external controls.

Set the thermostat knob "B" between "MIN" and "MAX" and check that the main burner cross lights smoothly from the pilot. Whilst the boiler is operating test gas valve and gas connections for gas soundness using a suitable leak detection fluid.

Note. Should the boiler fail to operate correctly refer to Fault Finding Section.

## 6 Commissioning

To set the burner pressure, operate the boiler for 10 minutes, remove the multifunctional control cover, if not already removed, as above. Adjust the gas burner pressure by screw "F" until the required pressure is obtained, see the relevant Table 1 for setting pressures.

Stick the self adhesive arrow from the loose items pack onto the appropriate space beneath the "Min" or "Max" column on the data label.

Should any doubt exist about the gas rate this should be checked at the meter using a stop watch to time at least a cubic foot of gas consumption.

Replace the multifunctional control cover.

Check the operation of the flame failure device, with the burner alight, as follows:- Slide the control button "K" inwards and release, the main burner and pilot will go out. Check that the flame failure device has operated, indicated by a "click", within 60 seconds, from the valve. The multifunctional control incorporates a safety device. Do not attempt to relight until it has reset, in about 3 minutes.

Remove the pressure gauge and refit the screw "E", making sure that a gas tight seal is made.

Set the thermostat knob "B" to "O" (the off position) and relight the pilot, as above.

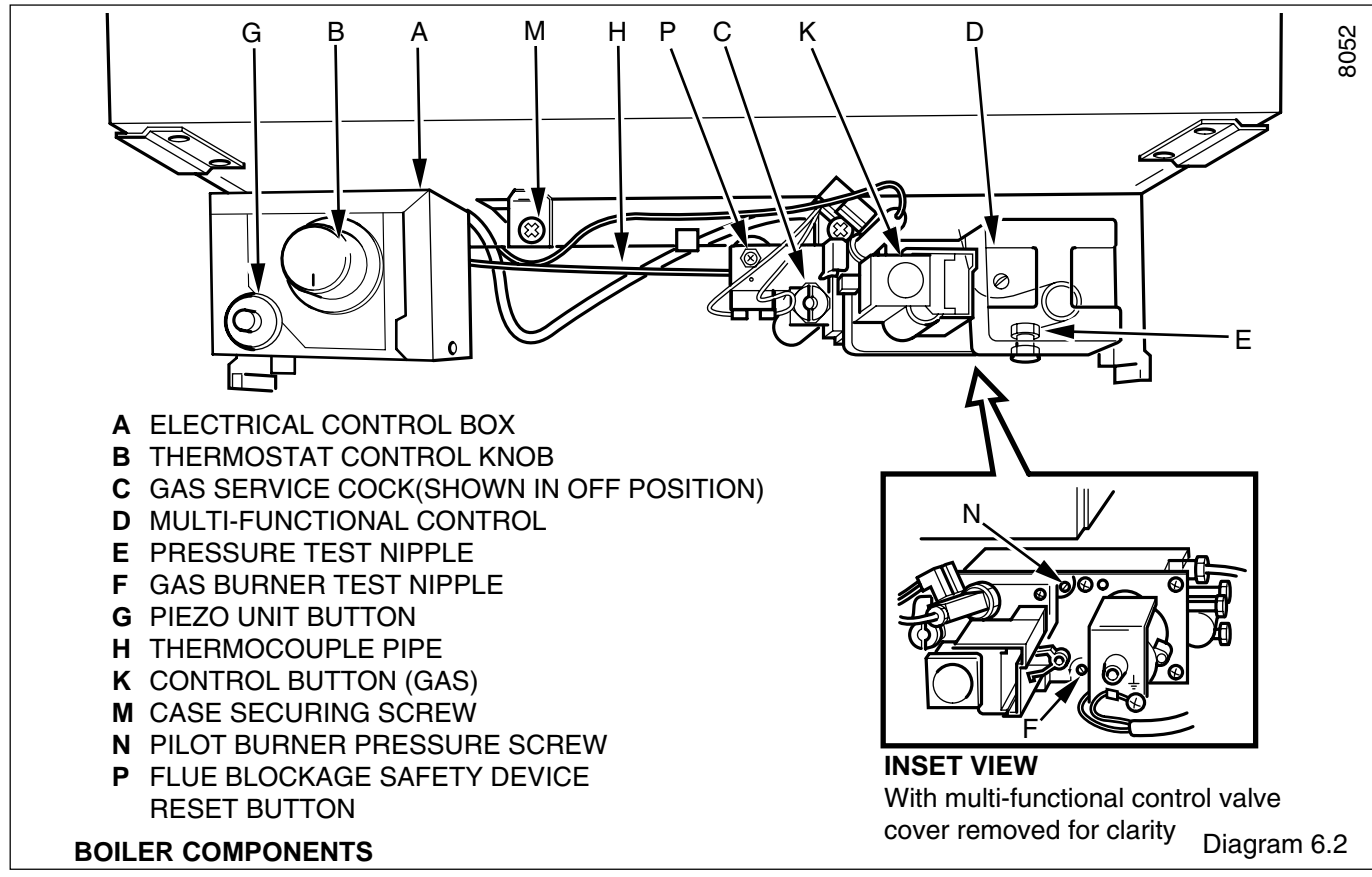
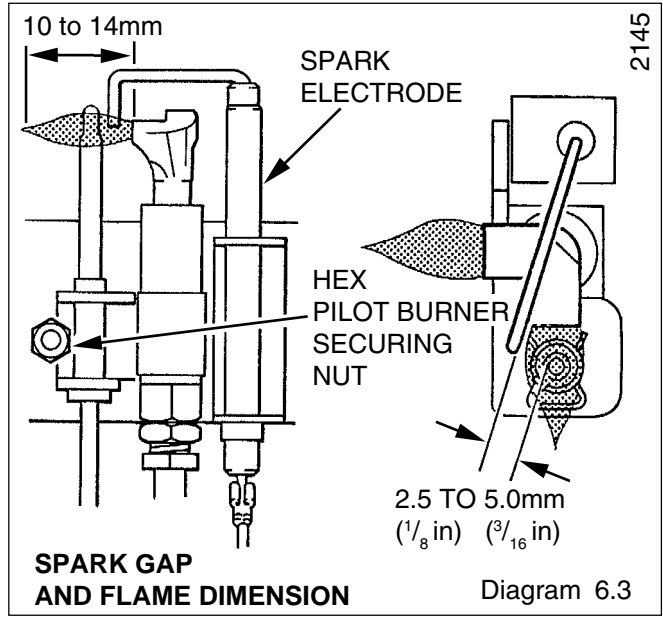
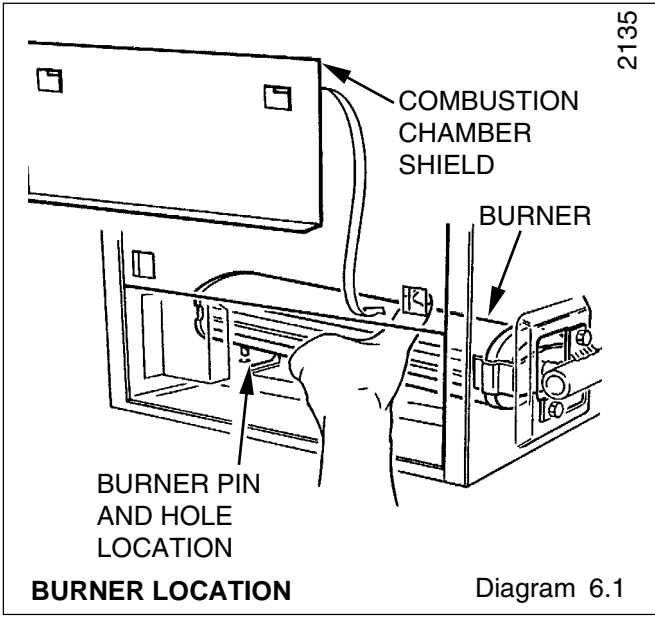

## 6 Commissioning

Check that the boiler thermostat and all external controls are operating as required.

Do not attempt to adjust the thermostat calibration screw.

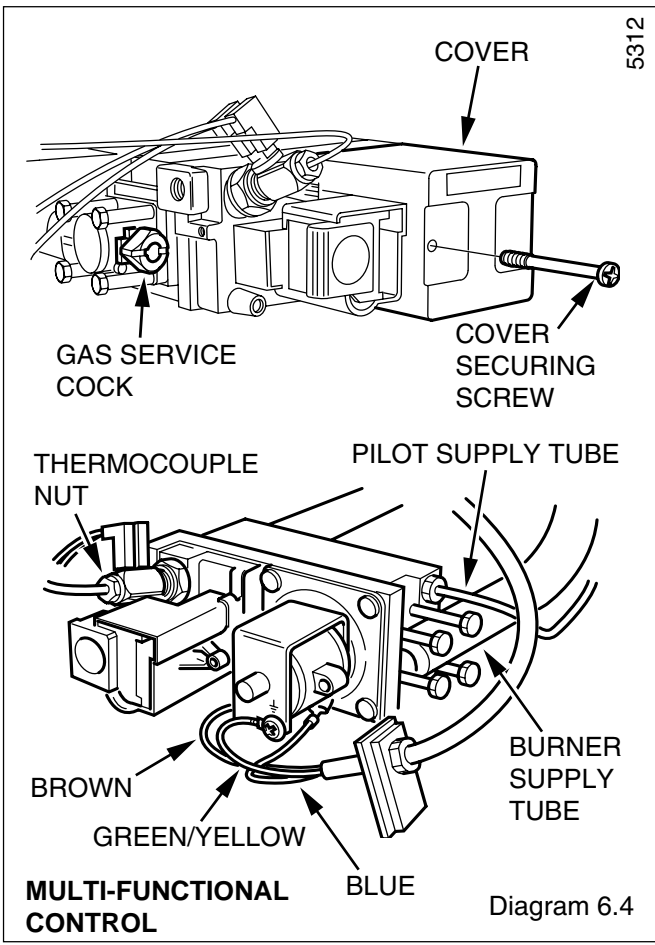

Relight the main burner and allow the system to warm up.

There should be no undue noise in the system and no pumping over of water or entry of air at the open vent.

Allow the system to reach maximum temperature and check for water soundness.

The burner should then be turned off and the system drained, as rapidly as possible, to complete the flushing process. Refill the system, heat up, vent and check again for water soundness.

If the side panels are to be fitted, remove the outer case. (Fit by fastening to the outer case using the securing screws, see diagram 6.5.)

Refit outer case and controls cover.

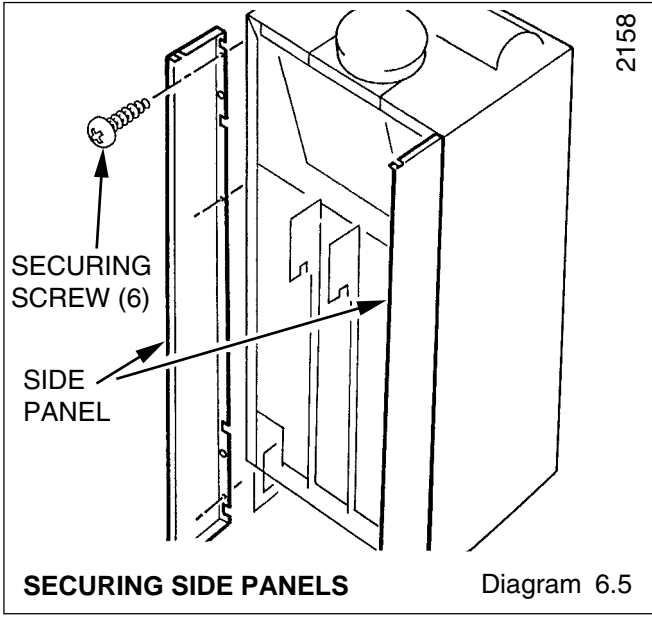

## 7 User Information

Hand the Instructions for Use to the user for their retention. Instruct and demonstrate the efficient and safe operation of the boiler, the heating system and if installed the domestic hot water system.

Advise that to ensure the continued efficient and safe operation of the boiler it is recommended that it is checked and serviced as necessary at regular intervals. The frequency of servicing will depend upon the particular installation conditions and usage, but in general once a year should be enough.

Draw attention, if applicable, to the current issue of the Gas Safety (Installation and Use) Regulations, Section 35, which imposes a duty of care on all persons who let out any property containing a gas appliance.

It is the Law that any servicing must be carried out by a competent person.

Advise that the boiler is fitted with a safety device and refer to the Instructions for Use.

Advise the user of the precautions necessary to prevent damage to the system and building in the event of the heating system being out of use during frost or freezing conditions.

Reminder, leave these instructions and the 'Benchmark' logbook with the user.

## 8 Servicing and Replacement of Parts

To ensure the continued efficient and safe operation of the boiler it is recommended that it is checked and serviced as necessary at regular intervals. The frequency of servicing will depend upon the particular installation conditions and usage, but in general once a year should be enough.

It is the Law that any servicing must be carried out by a competent person.

**BEFORE SERVICING OR REPLACING PARTS TURN OFF**

**THE GAS SUPPLY AND ISOLATE THE ELECTRICAL SUPPLY TO THE BOILER.**

**AFTER COMPLETING A SERVICE OR REPLACEMENT OF GAS CARRYING COMPONENTS ALWAYS TEST FOR GAS SOUNDNESS AND CARRY OUT FUNCTIONAL CHECKS ON CONTROLS.**

Unless stated otherwise replacement of parts is in the reverse order to removal.

## 8 Servicing and Replacement of Parts

### 8.1 Access

Refer to diagram 4.1 and 6.1.

Slide the controls cover off. Undo the screws and remove the outer case.

Lift the combustion chamber shield clear of the lugs and remove.

### 8.2 Main Burner

Refer to diagram 6.1.

Remove the main burner. Lift the left hand end of the burner to disengage the locating pin.

Slide the burner off the injector by moving it to the left, take care not to damage the pilot burner and electrode assembly. Bring the right-hand end of the burner through the opening first.

Service note: Clean the burner thoroughly, making sure that all the flame ports are clear.

### 8.3 Boiler Flueway Cleaning

Gain access as Section 8.1. Remove burner as Section 8.2. Refer to diagram 4.6 and 8.6.

Release split pin. Remove retaining angle and thermostat phial.

Undo the screws and remove the flue cleaning door.

Remove flueway baffle.

Place a sheet of paper in the combustion chamber, covering the electrode/pilot assembly, to catch the flue debris.

Clean the boiler flueways and fins thoroughly with a suitable stiff brush.

Re-assembly note: When replacing the flue cleaning door and flueway baffle ensure they are fitted as shown in diagram 4.6.

### 8.4 Multifunctional Control - Servicing/ Replacement

Gain access as Section 8.1.

Refer to diagram 6.4 and 8.1.

Remove multifunctional control cover securing screw.

Disconnect the electrical leads, thermocouple and pilot supply tube at the multifunctional control.

Remove the flue blockage safety device securing locknut and release from bracket, taking care not to strain the capillary.

Remove the two securing screws from the support bracket.

Undo the four screws each side of the multifunctional control to release the gas service cock and burner supply tube, take care not to damage the "O" rings.

Reassembly note 1: When refitting the gas valve take care not to damage the "O" rings.

Reassembly note 2: When fitting a replacement gas valve remove the bracket and fit to new one.

Refer to diagram 8.2.

To inspect the inlet screen and replace the pilot filter remove the base of the multifunctional control by releasing the five screws.

When reassembling take care not to damage the screen.

Remake the electrical connections.

NOTE. Do not tighten the thermocouple nut more than one quarter turn beyond finger tight.

It will be necessary to purge the pipework and multifunctional control before relighting, refer to Commissioning.

### 8.5 Multifunctional Control/Solenoid Replacement

Refer to diagram 8.3.

Remove the multifunctional control cover as described in Section 8.4.

Disconnect electrical leads, remove the solenoid retaining clip and solenoid.

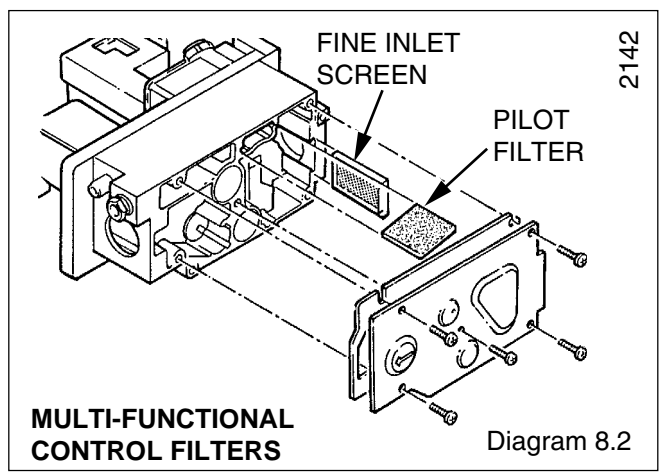
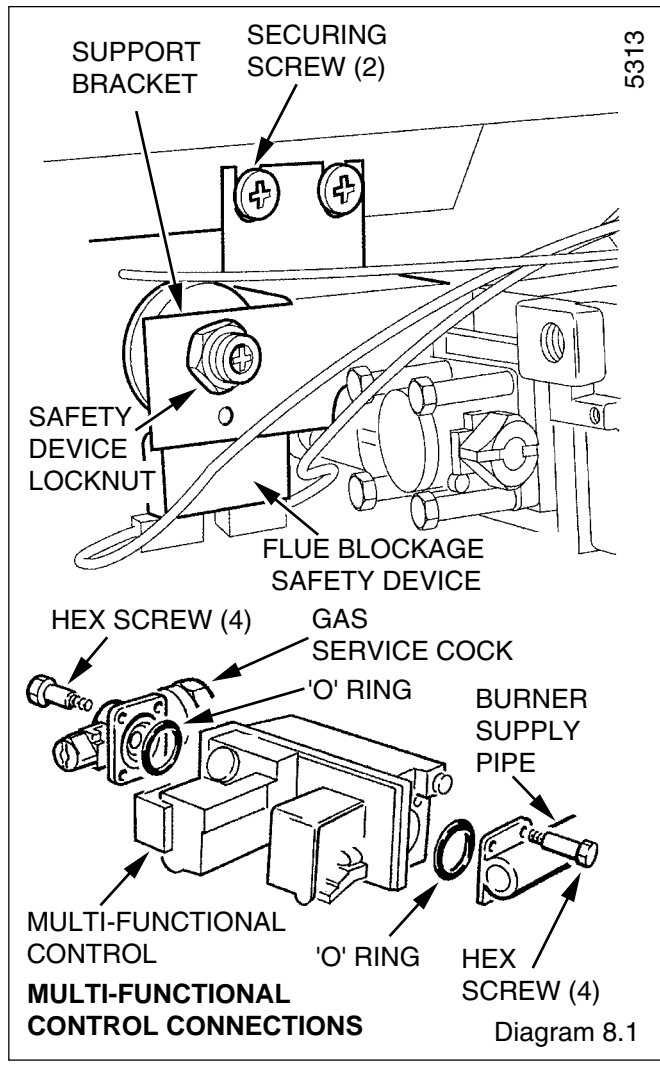

## 8 Servicing and Replacement of Parts

### 8.6 Main Injector

Gain access as Section 8.1.  
 Remove main burner as Section 8.2.  
 Remove the main burner injector from the right hand side of the combustion chamber.  
 Clean or replace as necessary. Do not clean with wire or sharp instrument.

### 8.7 Electrode

Gain access as Section 8.1. Refer to diagram 8.4.  
 Disconnect the electrode lead and remove electrode by undoing the retaining nut.

### 8.8 Pilot Burner Injector

Gain access as Section 8.1. Refer to diagram 8.4.  
 Remove the electrode as Section 8.7.  
 Disconnect the pilot supply tube by unscrewing the pilot tubing nut.

Ease the supply tube from the pilot injector and unscrew the injector.

### 8.9 Thermocouple

Gain access as Section 8.1. Refer to diagram 6.4.  
 Disconnect thermocouple from the interrupter from the gas valve.  
 Disengage the thermocouple spring clip and remove the thermocouple.  
 Re-assembly note: When refitting do not tighten the thermocouple nut more than a quarter turn beyond finger tight.

### 8.10 Pilot Burner

Gain access as Section 8.1. Refer to diagram 6.3 and 8.4.  
 Remove the main burner as described in Section 8.2.  
 Remove electrode as described in Section 8.7.  
 Disengage the thermocouple spring clip and carefully ease the thermocouple from the pilot burner.

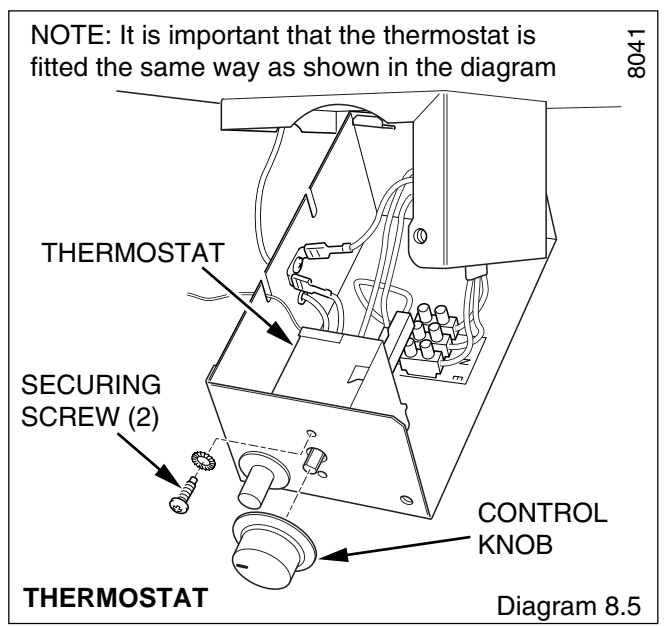
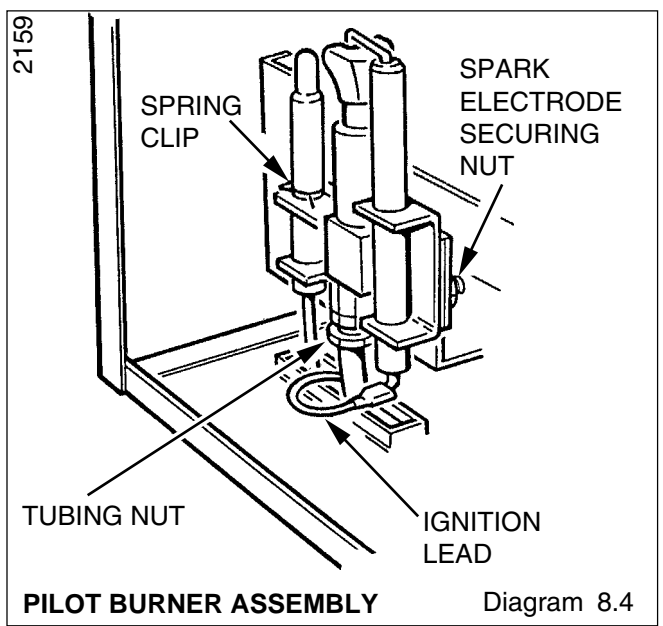
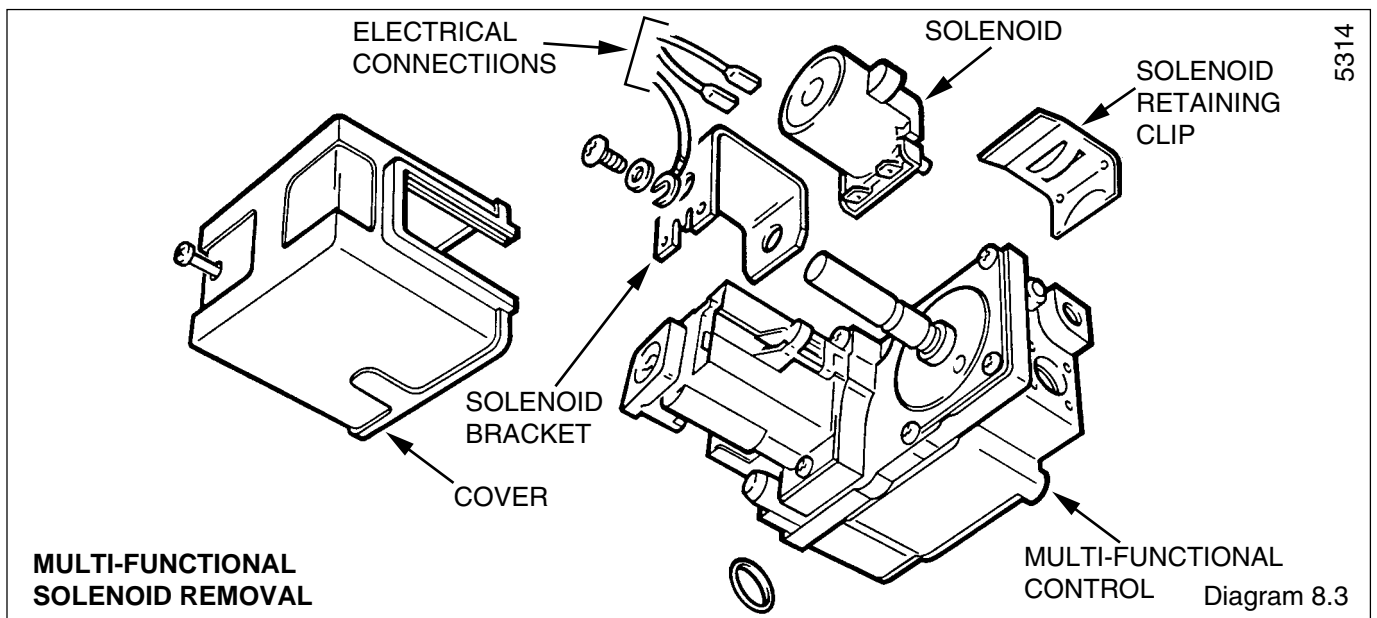

## 8 Servicing and Replacement of Parts

Disconnect the pilot supply tube by unscrewing the tubing nut. Remove the pilot burner by unscrewing the fixing at the left hand side.

Reassembly Note: When refitting check that the spark gap is correct and ensure that the thermocouple tip will be enveloped as shown in diagram 6.3.

### 8.11 Thermostat

Gain access as Section 8.1. Refer to diagram 5.2, 8.5, 8.6 and 8.7.

Remove and temporarily support the electrical control box as described in Section 5.1.

Remove the control knob. Remove the two electrical connections from the thermostat body.

Release the thermostat body by unscrewing the two screws in the front of the control box.

Remove the split pin. Withdraw the retaining angle and thermostat phial from its pocket.

Remove the thermostat from the boiler.

Re-assembly note: When fitting the thermostat, make sure that the thermostat is fully inserted into the phial pocket and then insert the retaining angle. Replace the split pin.

Remake electrical connections.

Make sure that the capillary is positioned as before so that it passes through the cut out in the control box, see diagram 8.5, and that any excess being coiled up tidily at the rear of the control box. There must be no kinks or sharp bends in the capillary.

### 8.12 Peizo Unit

Gain access as Section 8.1. Refer to diagram 8.7.

Remove the electrical control box, refer to Section 5.1.

Disconnect the ignition lead at the piezo unit.

Note: To ease the removal of the piezo unit it is advisable to temporarily remove the boiler thermostat from the control box, refer to Section 8.11.

Depress the retaining tabs and remove the Piezo unit.

### 8.13 Ignition Lead

Gain access as Sections 8.1 and 5.1.

Disconnect the lead at both ends and remove.

Re-assembly note: When replacing make sure the black end of the lead is attached to the piezo unit.

### 8.14 Flue Blockage Safety Device

Gain access as Section 8.1.

Remove the flue cleaning door, refer diagram 4.6.

Unscrew the two securing nuts and withdraw the phial assembly, see diagram 8.8.

Remove capillary from clips.

Remove the electrical connections from the safety device.

Remove the locknut securing the safety device to the bracket and withdraw the safety device.

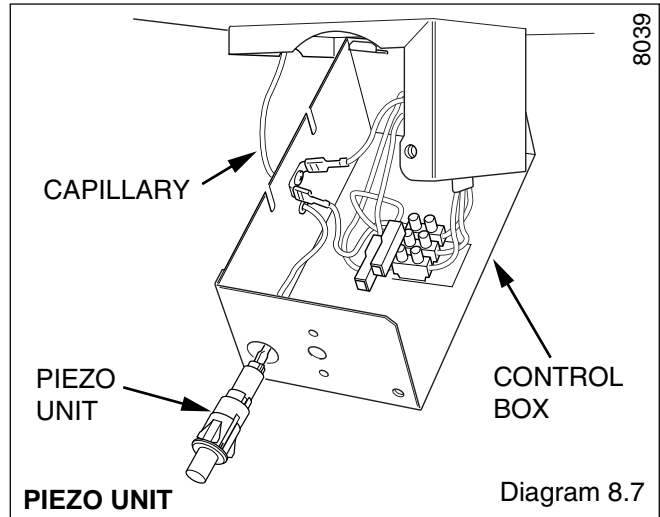

Diagram 8.7

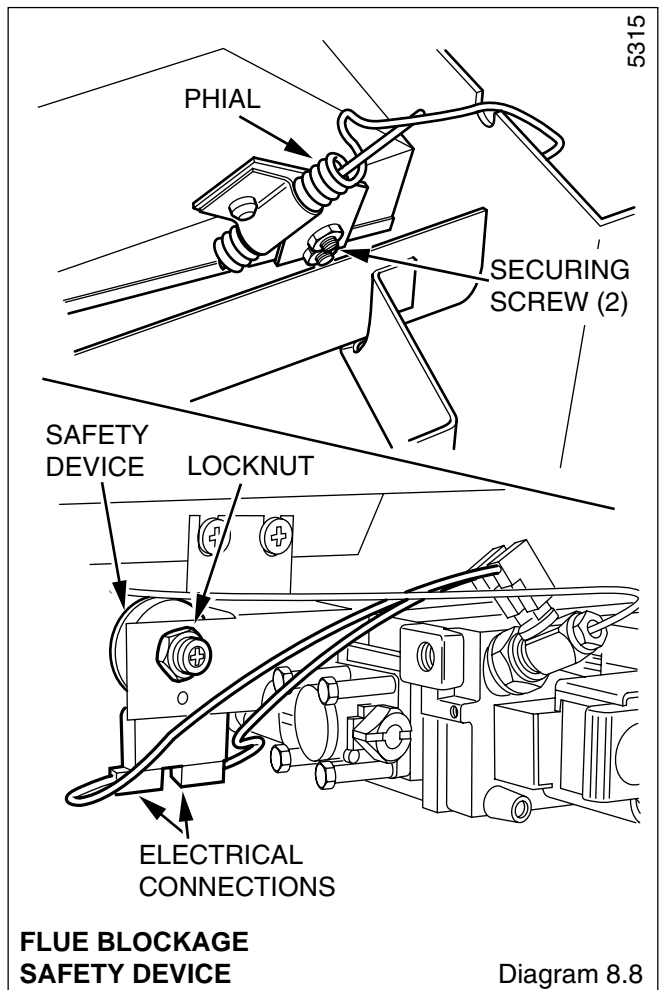

Diagram 8.8

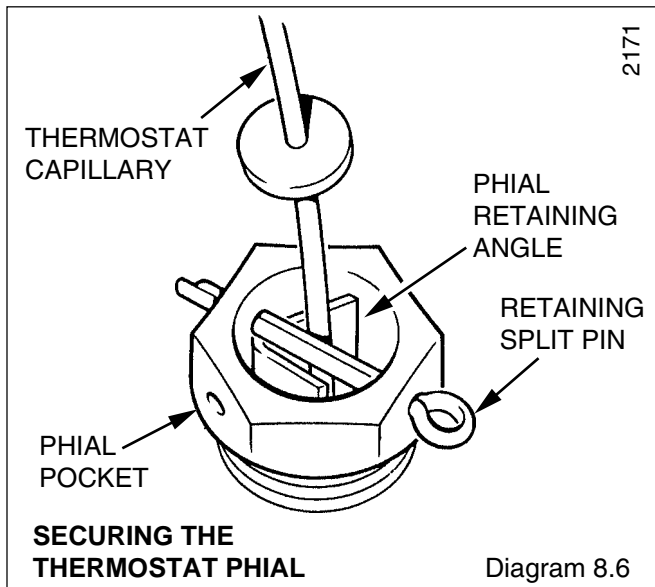
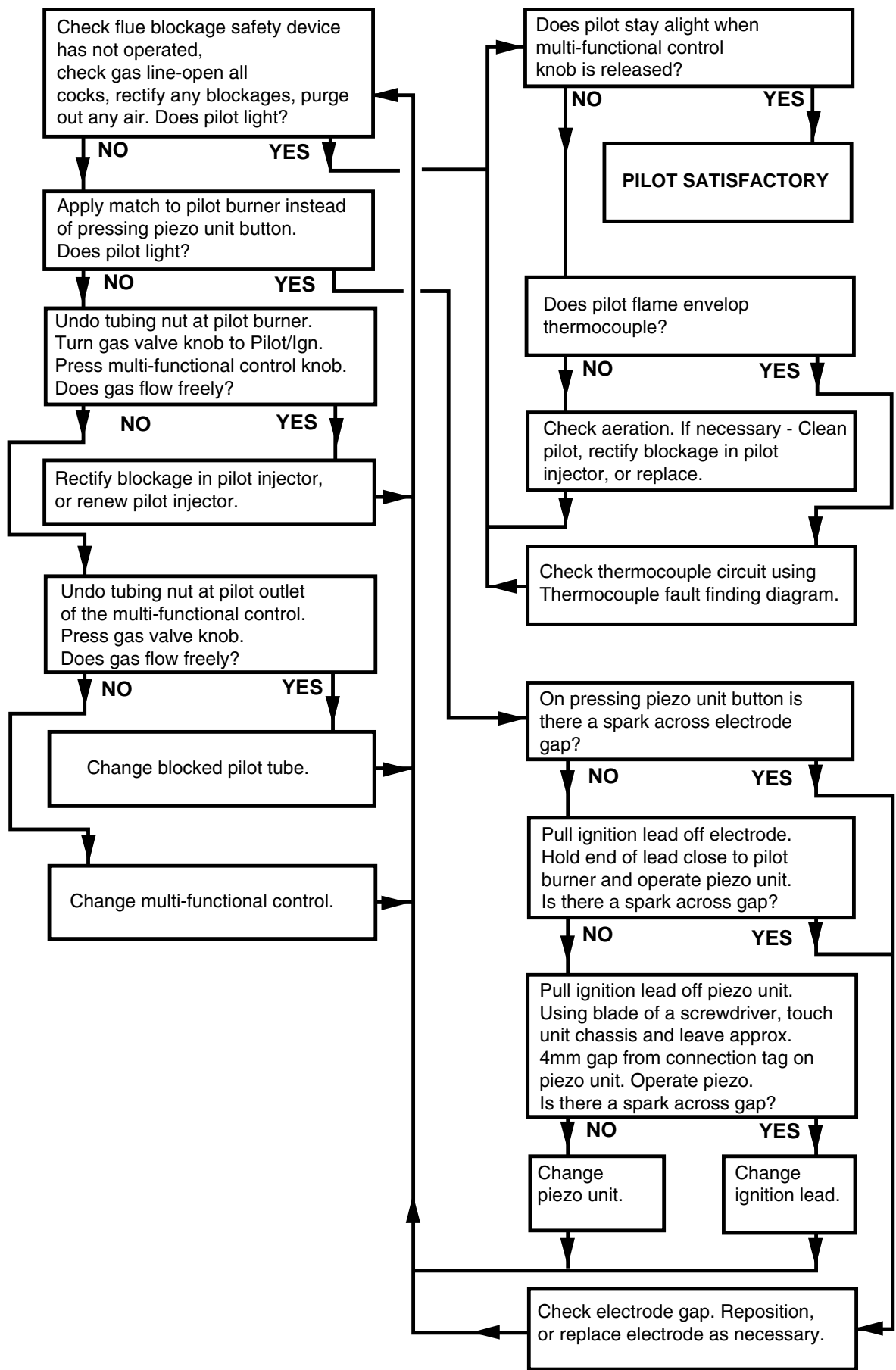

Diagram 8.6

# 9 Fault Finding

5291

## PILOT WILL NOT LIGHT START HERE



BOILER PILOT FAULT-FINDING

Diagram 9.1

## 9 Fault Finding

### 9.1 Pilot

Refer to chart 9.1.

### 9.2 Thermocouple

Refer to chart and diagram 9.2.

### 9.3 Electrical

Refer to diagram 9.3 and 9.4.

The preliminary electrical system checks as contained in a multimeter instruction book are the first checks to be carried out during fault finding.

On completion of any fault finding task which has required the breaking and remaking of electrical connections then the checks, earth continuity, polarity and resistance to earth, must be repeated.

### 9.4 Flue Blockage Safety Device

If the device operates it indicates there is a problem with the chimney. Make sure that the air vents are free from obstruction. Carryout spillage checks as Section 2.3.

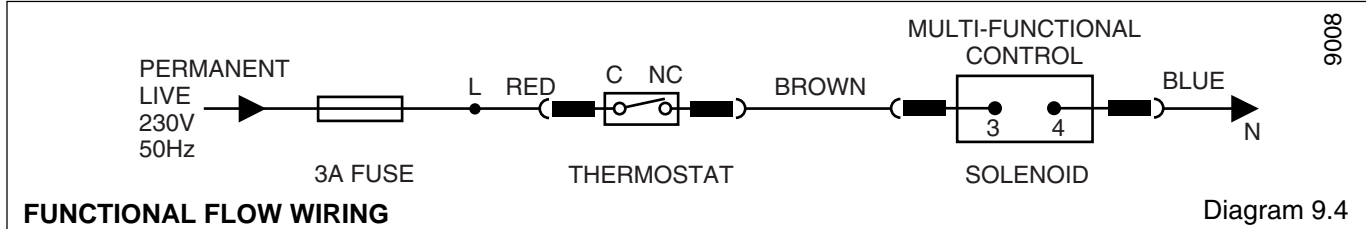
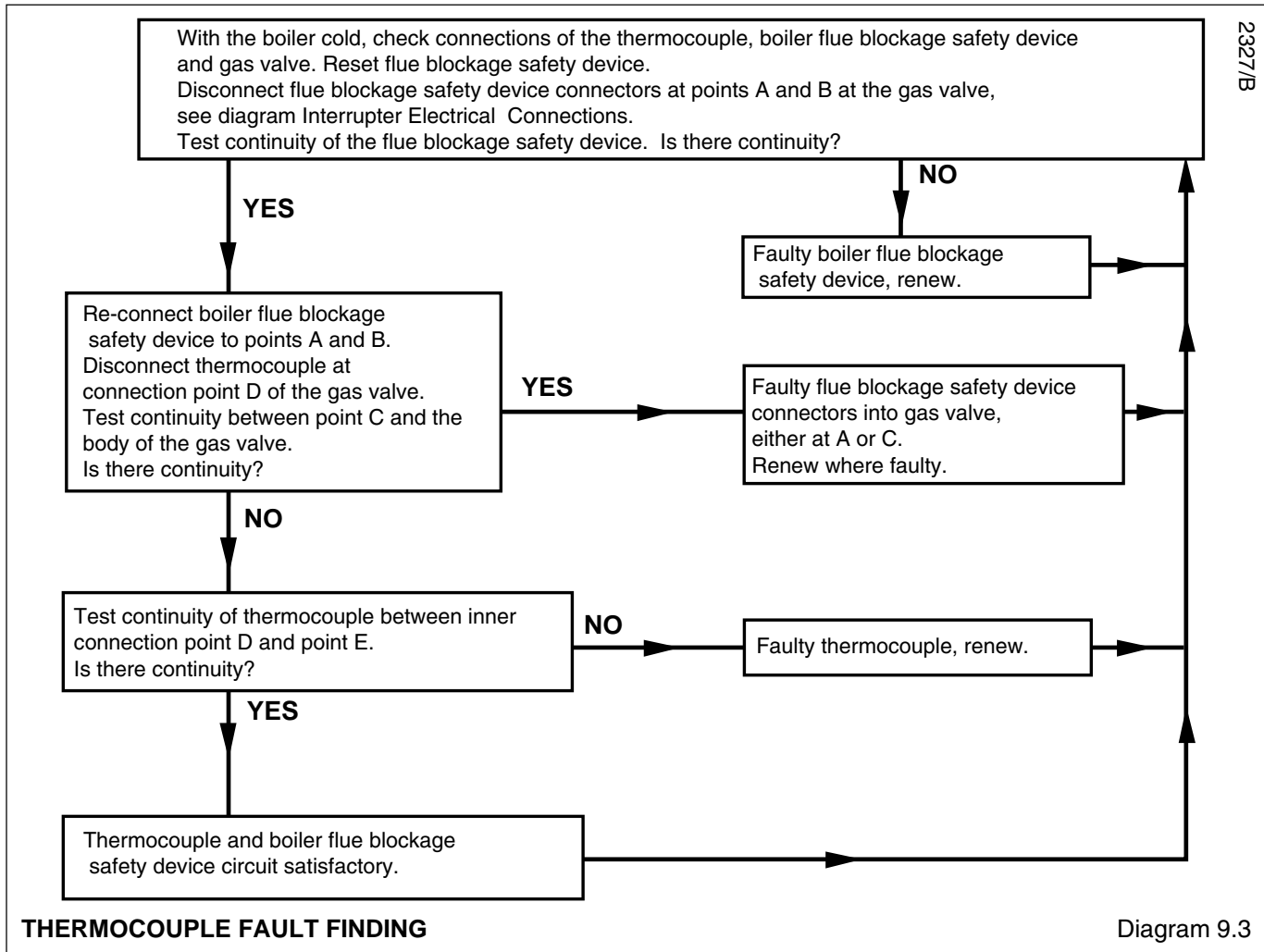
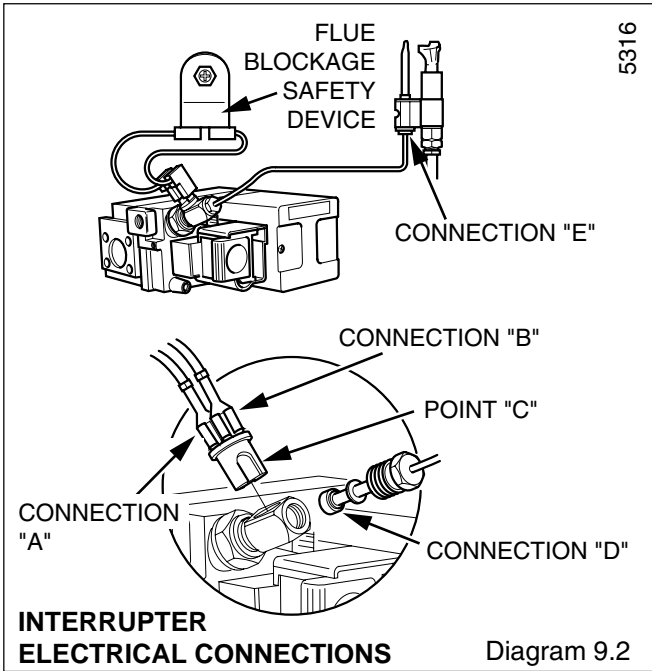

# 9 Fault Finding

0899/A

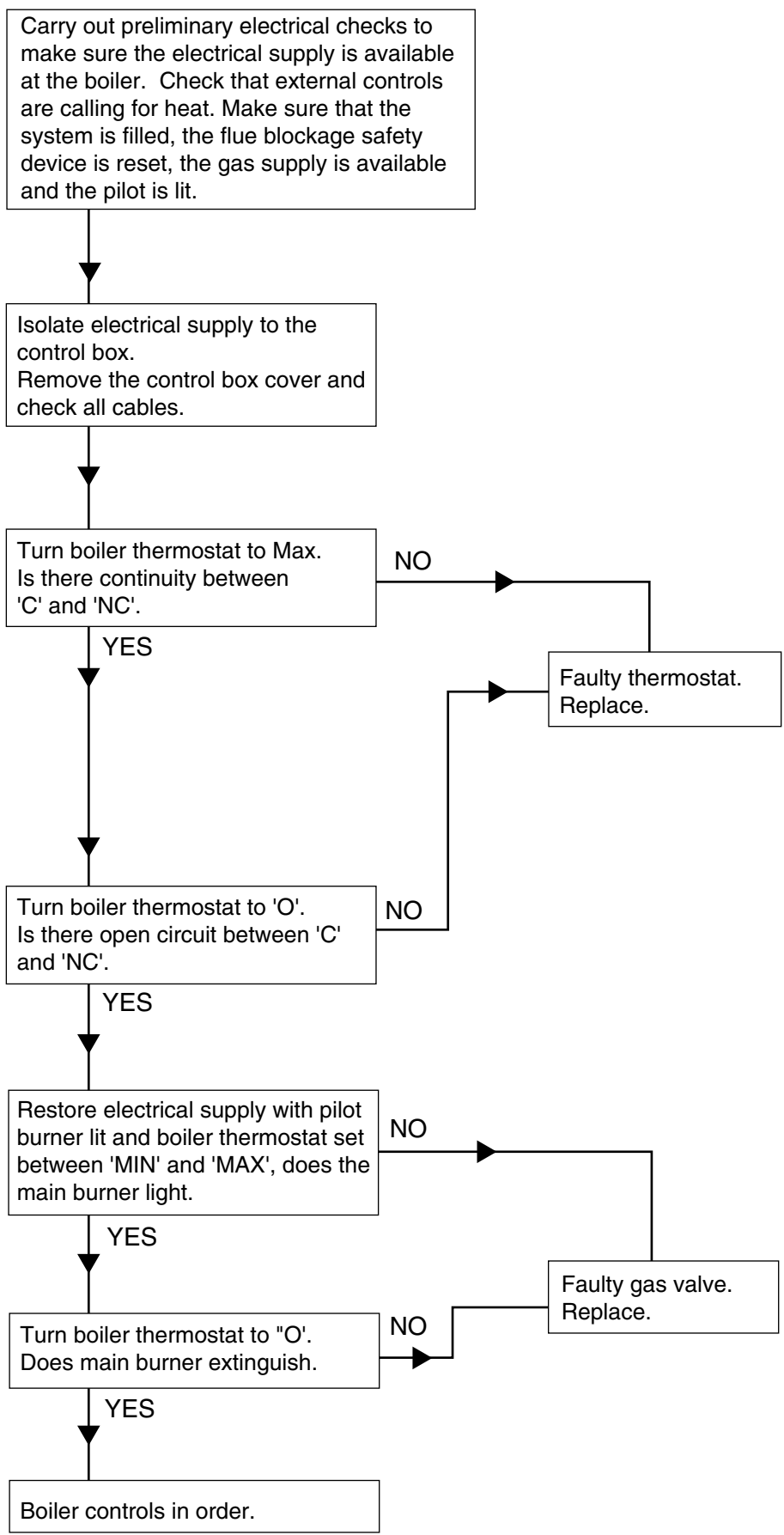

## 10 Replacement Parts

If replacement parts are required, apply to your local supplier. Please quote the name of the appliance and its serial number, found on the data label on the right hand side of the control box, after removal of the cover.

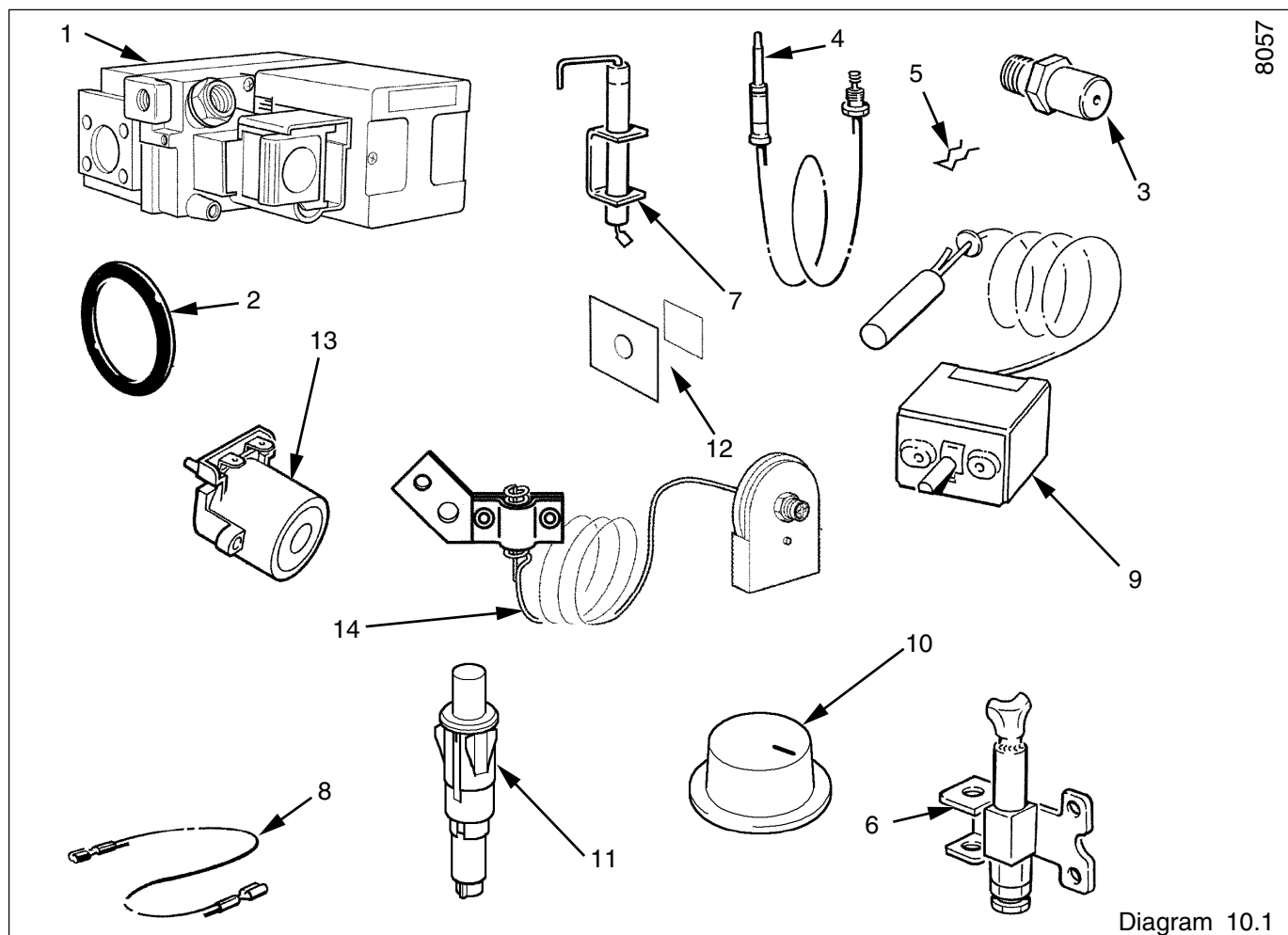

8057

Diagram 10.1

Key No	Part No	Description	G.C. Part No.
1	429549	Gas valve assembly	312 926
2	208040	"O" ring - gas valve	334 592
3	K8277	Injector	351 978
4	K2674	Thermocouple	390 894
5	K3580	Clip - thermocouple	390 983
6	203416	Pilot burner	381 793
7	900500	Spark electrode	381 733
8	WW4617	Ignition lead	312 997
9	202519	Thermostat	381 798
10	204687	Control knob	
11	202713	Piezo unit	
12	801236	Mica window and foil gasket	
13	203350	Solenoid	
14	800756	Safety device	278 470

*Because of our constant endeavour for improvement, details may vary slightly from those shown in these instructions.*