



221966B.04.03

# Instructions for Use Installation and Servicing

To be left with the user

## Ultimate

### 100FF 120FF

G.C. No. 41 047 59 G.C. No. 41 319 75

### Fanned Flue Boiler



This is a Cat I<sub>2H</sub> Appliance

Reference in these instructions to British Standards and Statutory Regulations/Requirements apply only to the United Kingdom. For Ireland the rules in force must be used.

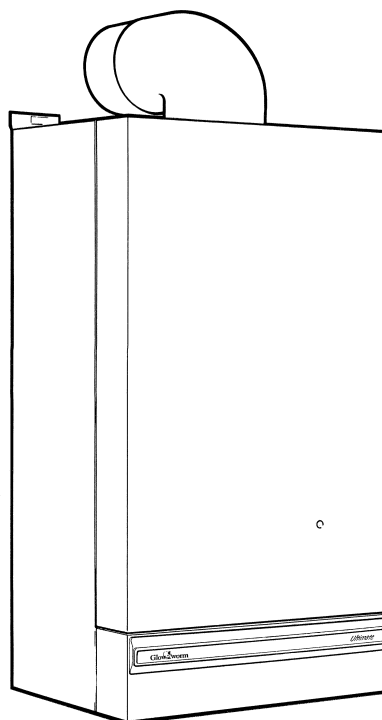

THIS DOCUMENT HAS BEEN PROVIDED BY



PLEASE VISIT [WWW.HEATINGSPPARES247.COM](http://WWW.HEATINGSPPARES247.COM) FOR FURTHER INFORMATION AND GENUINE PARTS & SPARES AT LOW PRICES

*The instructions consist of three parts, User, Installation and Servicing Instructions, which includes the Guarantee Registration Card. The instructions are an integral part of the appliance and must, to comply with the current issue of the Gas Safety (Installation and Use) Regulations, be handed to the user on completion of the installation.*

## Guarantee Registration

Thank you for installing a new Glow-worm appliance in your home.

Glow-worm appliances' are manufactured to the very highest standard so we are pleased to offer our customers' a Comprehensive First Year Guarantee.

In the centre pages are to be found your Guarantee Registration Card, which we recommend you complete and return as soon as possible.

If this card is missing you can obtain a copy or record your registration by telephoning the Heatcall Customer Service number 01773 828100.

Our Guarantee gives you peace of mind plus valuable protection against breakdown by covering the cost of:

- All replacement parts**
- All labour charges**
- All call-out charges**

REGISTER YOUR GLOW-WORM APPLIANCE  
FOR 1ST YEAR GUARANTEE PROTECTION

## CALL 0208 247 9857

**HEATCALL** Customer Services:  
Tel: (01773) 828100  
**One Contact Local Service** Fax: (01773) 828070

**Hepworth Heating Ltd.,**  
Nottingham Road, Belper, Derbyshire. DE56 1JT  
**General/Sales enquiries:**  
Tel: (01773) 824141 Fax: (01773) 820569

## Important Information

### Testing and Certification

This boiler is tested and certificated for safety and performance. It is therefore important that no alteration is made to the boiler, without permission, in writing, from Hepworth Heating Ltd.

Any alteration not approved by Hepworth Heating Ltd., could invalidate the certification, boiler warranty and may also infringe the current issue of the Statutory Requirements, see Section 1.4.

### CE Mark

This boiler meets the requirements of Statutory Instrument No. 3083 The boiler (Efficiency) Regulations, and therefore is deemed to meet the requirements of Directive 92/42/EEC on the efficiency requirements for new hot water boilers fired with liquid or gaseous fuels.

Type test for purposes of Regulation 5 certified by: Notified body 0086.

Product/production certified by: Notified body 0086.

The CE mark on this appliance shows compliance with:

1. Directive 90/396/EEC on the approximation of the laws of the Member States relating to appliances burning gaseous fuels.
2. Directive 73/23/EEC on the harmonization of the Laws of the Member States relating to the electrical equipment designed for use within certain voltage limits.
3. Directive 89/336/EEC on the approximation of the Laws of the Member States relating to electromagnetic compatibility.

### INFORMATION FOR THE INSTALLER AND SERVICE ENGINEER.

Under Section 6 of The Health and Safety at Work Act 1974, we are required to provide information on substances hazardous to health.

#### REFRACTORY CERAMIC FIBRE

This product uses insulation material containing Refractory Ceramic Fibre (RCF), which are man-made vitreous silicate fibres. Excessive exposure to these materials may cause temporary irritation to eyes, skin and respiratory tract, consequently, it makes sense to take care when handling these articles to ensure that the release of dust is kept to a minimum.

To ensure that the release of fibres from these RCF articles is kept to a minimum, during installation and servicing we recommend that you use a HEPA filtered vacuum to remove any dust accumulated in and around the boiler before and after working on the boiler. When replacing these articles we recommend that the replaced items are not broken up, but are sealed within heavy duty polythene bags, clearly labelled as RCF waste. This is not classified as "hazardous waste" and may be disposed of at a tipping site licensed for the disposal of industrial waste. Protective clothing is not required when handling these articles, but we recommend you follow the normal hygiene rules of not smoking, eating or drinking in the work area and always wash your hands before eating or drinking.

#### INSULATION PADS, GLASSYARN.

These can cause irritation to skin, eyes and the respiratory tract. If you have a history of skin complaint you may be susceptible to irritation. High dust levels are usual only if the material is broken. Normal handling should not cause discomfort, but follow normal good hygiene and wash your hands before eating, drinking or going to the lavatory. If you do suffer irritation of the eyes or severe irritation to the skin seek medical attention.

#### THERMOSTATS

These contain very small amounts of xylene in the sealed phial and capillary. If broken, under normal circumstances the fluid does not cause a problem, but in case of skin contact, wash with cold water. If swallowed drink plenty of water and seek medical attention

#### CUT-OFF DEVICES

These contain activated charcoal and a very small amount of chlorodifluoromethane in the sealed phial and capillary. If broken, under normal circumstances the fluid does not cause a problem. If there is irritation to the eyes or skin then seek medical attention.

#### Spare Parts

REMEMBER, When replacing a part on this appliance, use only spare parts that you can be assured conform to the safety and performance specification that we require. Do not use reconditioned or copy parts that have not been clearly authorised by Hepworth Heating Ltd.

**Important Information**

CONTENTS	DESCRIPTION	SECTION	PAGE No.
<b>INSTRUCTIONS FOR USE</b>	Introduction		3
	Lighting the Boiler		5
<b>INSTALLATION INSTRUCTIONS</b>	General Data	1	6
	Flue Terminal	2	9
	Water Systems	3	10
	Flue and Appliance Preparation	4	13
	Boiler Installation	5	17
	Flue Fixing	6	19
	Electrical Connectors	7	20
	Commissioning	8	21
	Instructions to the User	9	24
<b>SERVICING INSTRUCTIONS</b>	Servicing	10	24
	Fault Finding	11	27
	Replacement of Parts	12	31
	Spare Parts	13	34

**Instructions for Use**

**Introduction**

WARNING. It is important that the case (not the controls tray) is not disturbed or removed other than for servicing by a competent person.

Please read these instructions and follow them carefully for the safe and economical use of your boiler.

The Ultimate FF series are fanned flue boilers designed to provide central heating and indirect domestic hot water.

The boiler is fully automatic in operation having only one user control, the control thermostat.

**Important Notice**

This boiler is for use only on natural gas (G20).

**The Gas Safety (Installation and Use) Regulations**

In your interest and that of gas safety it is the law that ALL gas appliances are installed by a competent person in accordance with the above regulations.

**Gas Leak or Fault**

If a gas leak or fault exists or is suspected, the boiler must be turned off, including the electrical supply and must not be used until the fault has been put right.

Advice/help should be obtained from your installation/servicing company or the local gas undertaking.

**Electrical Supply Failure**

Failure of the electrical supply will cause the burner to go out. Should this occur, operation of the appliance will normally resume after the electrical supply is restored.

If the boiler does not relight after an electrical supply failure the overheat safety cutoff device may need resetting, remove the controls cover and press the reset button, refer to diagram 1.

**Overheat Safety Cutoff**

If the overheat safety cutoff device operates on any other occasion than an electrical supply failure, press the reset button as in "Electrical Supply Failure". If the overheat operates again, turn the appliance off and contact your installation/servicing company.

# Instructions for Use

## Maintenance

To ensure the continued efficient and safe operation of the boiler it is recommended that it is checked and serviced as necessary at regular intervals. The frequency of servicing will depend upon the particular installation conditions and usage, but in general once a year should be enough.

If this appliance is installed in a rented property there is a duty or care imposed on the owner of the property by the current issue of The Gas Safety (Installation and Use) Regulations, Section 35.

It is the law that any servicing is carried out by a competent person.

To obtain service, please call your installer or Heatcall (Glow-worm's own Service Organisation) using the telephone number given on the controls tray.

Please be advised that the 'Benchmark' logbook should be completed by the installation engineer on completion of commissioning and servicing.

All CORGI Registered Installers carry a CORGI ID card, and have a registration number. Both should be recorded in your boiler Logbook. You can check your installer is CORGI registered by calling CORGI direct on :- 01256 372300.

## Boiler Clearances

If fixtures are positioned close to the boiler space must be left as shown in diagram 2. At least a minimum clearance of 500mm must be left in front of the boiler to allow for servicing.

## Boilers Installed in a Compartment or Cupboard

If the boiler is installed in a compartment or cupboard do not obstruct any ventilation openings.

Do not use the compartment or cupboard for storage.

## Cleaning

**WARNING.** This appliance contains metal parts (components) and care should be taken when handling and cleaning, with particular regard to edges.

Clean the casing occasionally by wiping it over with a damp cloth or dry polishing duster.

Do not use an abrasive cleaner.

## Boiler Electrical Supply

**WARNING.** This boiler must be earthed.

The boiler must only be connected to a 230V~50Hz supply protected by a 3A fuse.

All wiring must be in accordance with the current issue of BS7671.

Wiring to the boiler must be PVC insulated type to the current issue of BS6500 Table 16, not less than 0.75mm<sup>2</sup> (24/0.20mm).

The colours of three core flexible cable are:

Brown - live, Blue - neutral,

Green/yellow - earth.

As the markings on your plug may not correspond with these colours continue as follows:

The cable coloured blue must be connected to the terminal marked "N" or black.

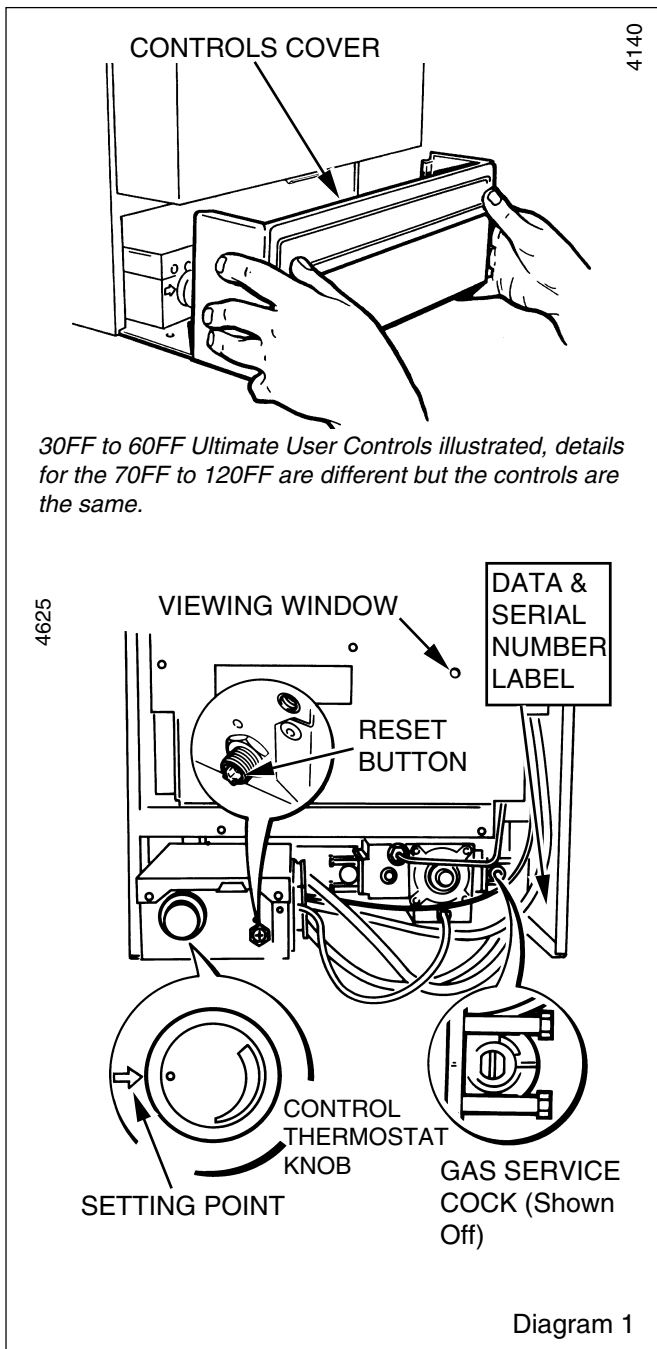

The cable coloured brown must be connected to the terminal marked "L" or red.

The cable coloured green/yellow must be connected to the terminal marked "E", or green or the earth symbol ⊥.

# Instructions for Use

## To Light the Boiler

### WARNING. Sealed Systems

A sealed water system must be filled and pressurised by a competent person.

Only light the boiler when you are sure that the system has been filled and pressurised.

The pressure gauge should show at least 0.7bar, anything less than this figure could indicate a leak and you MUST contact your installation/servicing company.

If there is any doubt about the boiler being full of water consult your installation/servicing company.

### ALL SYSTEMS.

Turn the electrical supply on to the boiler and check that all remote controls are calling for heat.

## To Turn the Boiler On

Remove the controls cover, by withdrawing it forward and off, see diagram 1.

Turn the control thermostat knob clockwise to any position between MIN and MAX. The maximum temperature setting is about 82°C (180°F), see diagram 1.

The boiler lighting operation is now automatic as follows.

The fan operates, followed by an ignition spark until the pilot is lit. When the pilot is alight the ignition system switches off and the main burner lights. The flames can be seen through the viewing window, see diagram 1.

The main burner will remain alight until switched off by the control thermostat or any remote control.

If the boiler is switched OFF, by hand, wait at least 30 seconds before switching on again.

When the boiler switches off, both the pilot and main burner go out.

The automatic lighting sequence will operate again when heat is required.

Refit the controls cover.

It should be noted that this is a fan flue appliance and fan operation may be heard.

## To Turn the Boiler Off

For short periods, turn the control thermostat knob anti-clockwise to "O" Off. To relight, turn the control thermostat knob to any position between "MIN" and "MAX".

For longer periods, turn the control thermostat knob fully anti-clockwise to "O" Off and switch off the electrical supply to the boiler.

To relight follow the lighting sequence given above.

## Protection Against Freezing.

If the boiler is to be out of use for any long period of time during severe weather conditions we recommend that the whole of the system, including the boiler, be drained off to avoid the risk of freezing up. Make sure that, if fitted, the immersion heater in the cylinder is switched off.

For the position of the serial number, see diagram 1.

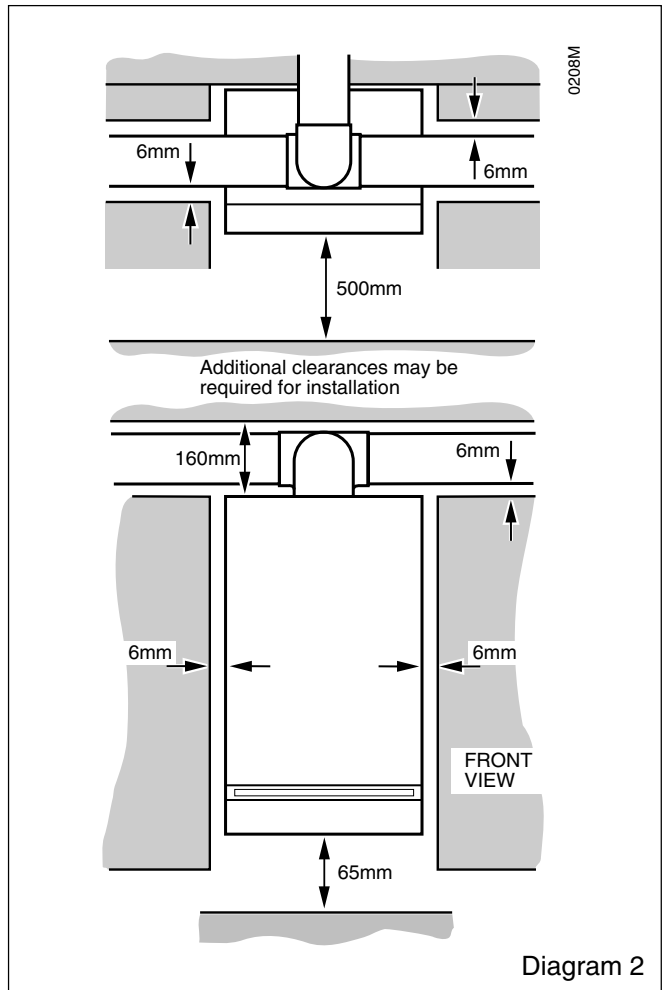

**1 General**

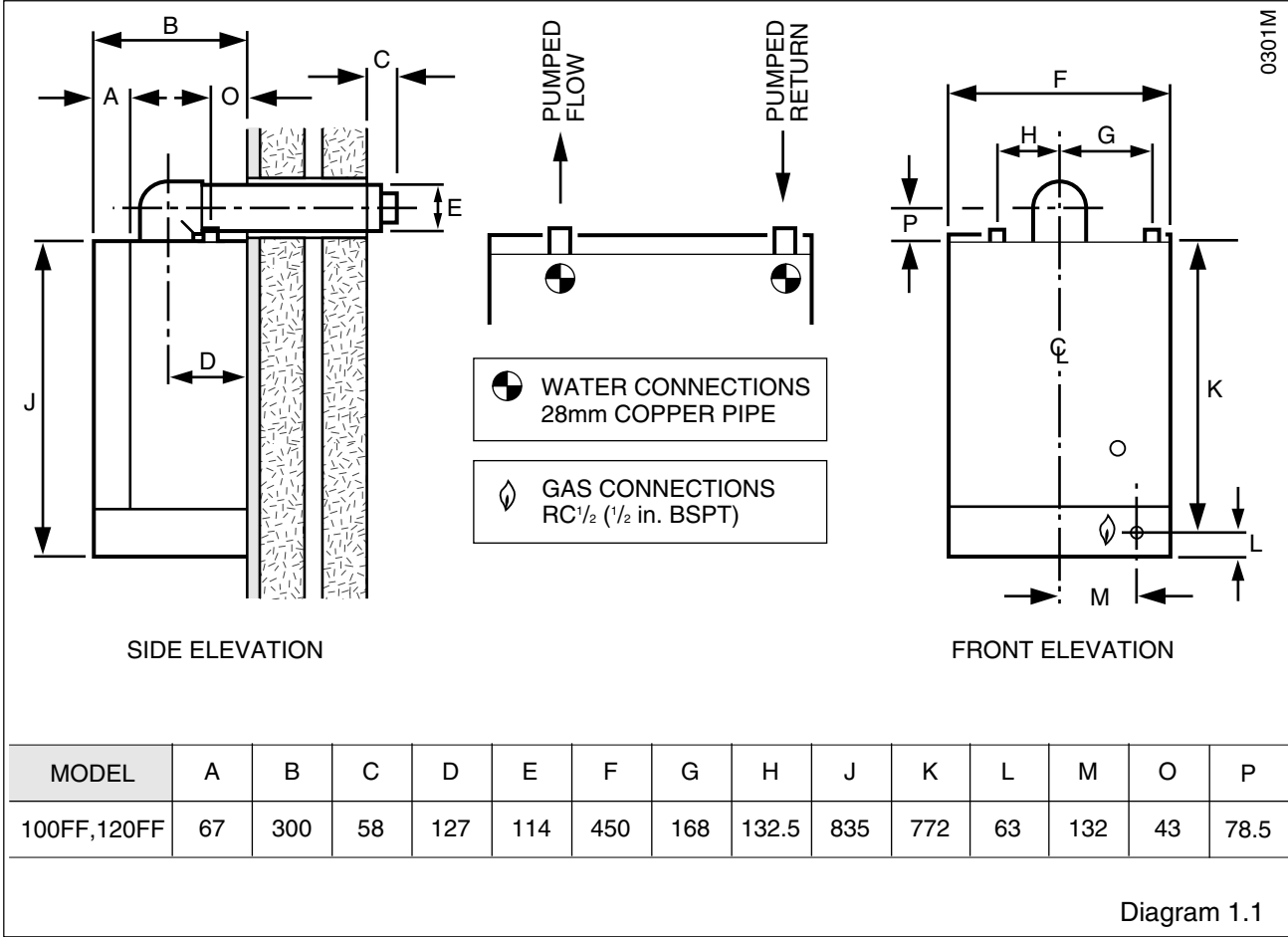

**Important Notice**

This boiler is for use only on G20 gas.  
 This boiler can be used on an open vented or sealed water system.  
 When used on an open vented system domestic hot water can only be provided by pumped circulation to the indirect cylinder.  
 Wherever possible, all materials, appliances and components used shall comply with the requirements of applicable British Standards.  
 Where no British Standard exists, materials and equipment should be fit for their purpose and of suitable quality and workmanship.

**Sheet Metal Parts**

**WARNING.** When installing or servicing this boiler care should be taken when handling sheet metal parts, to avoid any possibility of personal injury.

**1.1 Statutory Requirements**

The installation of the boiler must be carried out by a competent person in accordance with the relevant requirements of the current issue of:-  
 Manufacturer's instructions, supplied.  
 The Gas Safety (Installation and Use) Regulations, The Building Regulations, The Building Standards (Scotland) Regulations (applicable in Scotland), Local Water Company Byelaws, The Health and Safety at Work Act, Control of Substances Hazardous to Health, The Electricity at Work Regulations and any local regulations which may apply.  
 Detailed recommendations are contained in the current issue of the following British Standards and Codes of Practice:-  
 BS6798, BS5440 Part 1 and 2, BS5546 Part 1, BS5449, BS6891, BS6700, BS7478, BS7593, BS7671.  
 Manufacturer's instructions must not be taken as overriding statutory requirements.

**1.2 Data**

See Table 1  
 All dimensions are given in millimetres (except as noted).  
 The Seasonal Efficiency Domestic Boilers UK (SEDBUK) is Ultimate 100FF = 79, Ultimate 120FF = 78.1.  
 The value is used in the UK Government's Standard Assessment Procedure (SAP) for energy rating of dwellings. The test data from which it has been calculated have been certified by B.S.I.

# 1 General

DATA TABLE 1.		
MODEL	100FF	120FF
TOTAL DRY WEIGHT (Including Terminal)	71.0 kg (157 lb)	71.0 kg (157 lb)
* LIFT WEIGHT	63.3 kg (140 lb)	63.3 kg (140 lb)
WATER CONTENT	3.8 litres (0.84 gal)	3.8 litres (0.84 gal)
GAS CONNECTION	Rc 1/2 in.	
ELECTRICITY RATING	71W	97W
	Internal fuse F1 & F2 (F1A)	
WATER CONNECTION	2x28mm copper pipes from top of case	
ELECTRICITY SUPPLY	230V~50Hz, fused 3A	
DATA LABEL	Bottom right hand side of case	

9072

TABLE 2. 100FF				
RANGE RATING	Min.	Med.	Max.	
NOMINAL HEAT INPUT (NETT)	kW 26.44 Btu/h 90,210	29.24 99,760	32.38 110,485	
NOMINAL HEAT OUTPUT	kW 23.45 Btu/h 80,000	26.38 90,000	29.31 100,000	
BURNER SETTING PRESSURE	m bar 9.2 in. wg. 3.7	11.6 4.7	14.4 5.8	
APPROX. GAS RATE	m <sup>3</sup> /h 2.8 ft <sup>3</sup> /h 100	3.1 111	3.5 123	
BURNER INJECTOR MARKING: 205727				
BURNER INJECTOR SIZE: 4.7mm				

9715

TABLE 2. 120FF				
RANGE RATING	Min.	Medium.	Max.	
NOMINAL HEAT INPUT (NETT)	kW 33.43 Btu/h 114,066	36.52 124,608	39.6 135,150	
NOMINAL HEAT OUTPUT	kW 29.3 Btu/h 100,000	32.24 110,000	35.17 120,000	
BURNER SETTING PRESSURE	m bar 9.9 in. wg. 4.0	12.0 4.8	14.2 5.7	
APPROX. GAS RATE	m <sup>3</sup> /h 3.5 ft <sup>3</sup> /h 125	3.9 137	4.2 148	
BURNER INJECTOR MARKING: 205726				
BURNER INJECTOR SIZE: 5.2mm				

### 1.3 Range Rating

This boiler is range rated and may be adjusted to suit individual system requirements.

Table 2 gives the ratings and settings.

\*Note: Lift weight is with Flue Elbow, Controls Cover and Front Cover removed.

### 1.4 B.S.I. Certification

This boiler is certificated to the current issue of BS6332 Part 1, invoking the current issue of BS5258 Part 1 for performance and safety. It is, therefore, important that no alteration is made to this boiler without permission, in writing, from Hepworth Heating Ltd.

Any alteration that is not approved by Hepworth Heating Ltd., could invalidate the B.S.I. Certification of the boiler, warranty and could also infringe the current issue of the Statutory Requirements.

### 1.5 Gas Supply

The gas installation shall be in accordance with the current issue of BS6891.

The supply from the governed meter must be of adequate size to provide a steady inlet working pressure of 20mbar (8in wg) at the boiler.

On completion test the gas installation for soundness using the pressure drop method and suitable leak detection fluid, purge in accordance with the above standard.

### 1.6 Electrical Supply

**WARNING.** This boiler must be earthed.

All system components shall be of an approved type and shall comply with and be connected in accordance with the current issue of BS7671 and any applicable local regulations.

Connection of the boiler and system controls to the mains supply must be through a common isolator and must be fused

3A, maximum. This method of connection must be by a fused double pole isolating switch with a minimum contact separation of 3mm on both poles. The switch should be readily accessible and preferably adjacent to the appliance. It should supply the appliance only and be easily identifiable as so doing.

Alternatively, an unswitched shuttered socket outlet and 3A fused 3 pin plug both to the current issue of BS1363 may be used, provided that they are not used in a room containing a bath or shower.

Wiring to the boiler must be PVC insulated type to the current issue of BS6500 Table 16.

### 1.7 Contents of Packaging

The boiler is delivered in one pack, refer to Section 4.1 for contents.

Refer to Section 4.2 to check that the flue terminal assembly supplied is suitable.

# 1 General

## 1.8 Water System

This boiler may be fitted to an open vented or sealed water system.

It is recommended that plastic pipes for primary pipework should not be used for this boiler.

## 1.9 Drain

### System

A draining tap must be provided at the lowest points of the system which will allow the entire system, boiler and hot water cylinder to be drained.

Draining taps should be to the current issue of BS2879.

### Boiler

A draining point is fitted at the bottom right hand side of the heat exchanger.

Cover controls to avoid water damage.

If required remove the combustion chamber front cover to improve access.

## 1.10 Safety Valve

A safety valve need not be fitted to an open vented system.

## 1.11 Location

This boiler is not suitable for outdoor installation.

This boiler may be installed in any room, although particular attention is drawn to the requirements of the current issue of BS7671 with respect to the installation of a boiler in a room containing a bath or shower. Any electrical switch or boiler control utilising mains electricity should be placed so that it cannot be touched by a person using the bath or shower. The electrical provisions of the Building Standards (Scotland) apply to such installations in Scotland.

The boiler must be mounted on a flat wall which is sufficiently robust to take its total weight.

The boiler may be fitted to a wall made of combustible material.

## 1.12 Boiler Clearances

Refer to diagram 1.2.

The boiler must be positioned so that at least the minimum operational and servicing clearances are provided.

Additional clearances may be required for installation.

If fixtures are positioned next to the boiler they should be made removable for access to pipework.

Sufficient clearance must be left in front of the boiler for servicing.

## 1.13 Room Ventilation

The boiler is room sealed and does not require the room or space containing it to have permanent airvents.

## 1.14 Boilers in a Compartment

Where the installation of the boiler will be in an unusual position, special requirements are needed, the current issue of BS6798 gives detailed guidance on these requirements.

A compartment used to enclose the boiler must be designed and constructed specifically for this purpose. An existing cupboard or compartment modified for the purpose may be used. Details of essential requirements for cupboard or compartment design are given in the current issue of BS6798.

The doorway opening should be of sufficient size to allow for easy removal of the boiler.

Where the boiler is fitted in a cupboard or compartment, permanent high and low level ventilation must be provided. The minimum ventilation areas are given in Table 3.

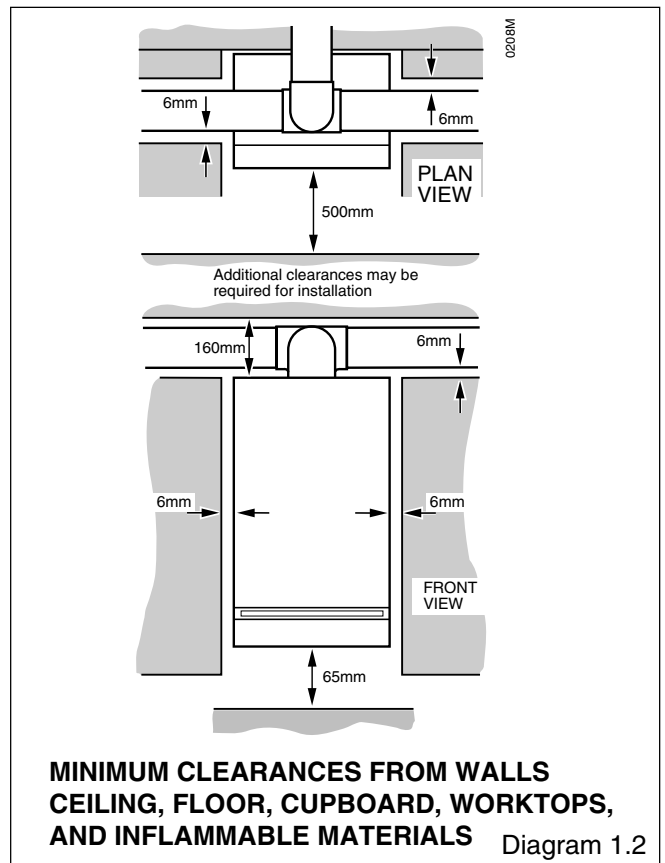

VENTILATION REQUIREMENTS	MODEL	HIGH LEVEL VENT AREA		LOW LEVEL VENT AREA	
		cm <sup>2</sup>	in <sup>2</sup>	cm <sup>2</sup>	in <sup>2</sup>
VENTILATION FROM ROOM OR SPACE	100FF	330	51	330	51
	120FF	396	61.5	396	61.5
VENTILATION FROM OUTSIDE	100FF	165	25.5	165	25.5
	120FF	198	30.5	198	30.5

## 1.15 Timber Frame Building

If the boiler is to be installed in a timber frame building it should be fitted in accordance with the Institute of Gas Engineers document IGE/UP/7/1998. If in doubt seek advice from the local gas undertaking or Hepworth Heating Ltd.

## 1.16 Heating System Controls

The heating system should have installed: a programmer and room thermostat controlling the boiler.

Thermostatic radiator valves may be installed, however they must not be fitted in a room where the room thermostat is located.

Note: For further information, see The Building Regulations 1991 - Conservation of fuel and power, 1995 edition - Appendix G, table 4b.

## 2 Flue Terminal

Note. Detailed recommendations for flues are given in the current issue of BS5440 Part 1.

### 2.1 Terminal Position

The minimum acceptable siting dimensions for the terminal from obstructions, other terminals and ventilation openings are shown in diagram 2.1.

The terminal must be exposed to the external air, the position allowing free passage of air across it at all times.

Car ports or similar extensions of a roof only, or a roof and one wall, require special consideration with respect to any openings, doors, vents or windows under the roof. Care is required to protect the roof if it is made of plastic sheeting. If the car port consists of a roof and two or more walls, seek advice from the local gas company before installing the boiler.

If the terminal is fitted within 600mm below plastic guttering or painted soffit an aluminium shield 1500mm long should be fitted immediately beneath the guttering or eaves. If the terminal is fitted within 450mm below painted eaves or a painted gutter, an aluminium shield 750mm long should be fitted immediately beneath the guttering or eaves.

### 2.2 Terminal Guard

A terminal guard is required if persons could come into contact with the terminal or the terminal could be subject to damage.

If a terminal guard is required, it must be positioned to provide a minimum of 50mm clearance from any part of the terminal and be central over the terminal.

A suitable guard, reference Type K3, can be obtained from:

Tower Flue Components Ltd  
Morley Road  
Tonbridge  
Kent  
TN9 1RA

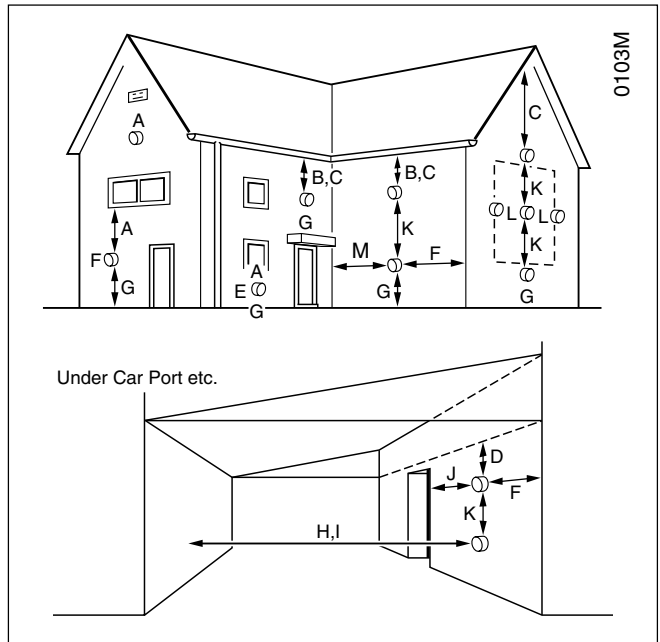

**MINIMUM SITING DIMENSIONS FOR FANNED FLUE TERMINALS POSITION** **MINIMUM SPACING in mm**

<b>A DIRECTLY BELOW, ABOVE OR HORIZONTALLY TO AN OPENING, AIR BRICK, OPENING WINDOWS, AIR VENT OR ANY OTHER VENTILATION OPENING.</b>	<b>300</b>
<b>B BELOW GUTTER, DRAIN/SOIL PIPE</b>	<b>75</b>
<b>C BELOW EAVES</b>	<b>200</b>
<b>D BELOW A BALCONY OR CAR PORT</b>	<b>200</b>
<b>E FROM VERTICAL DRAIN PIPES AND SOIL PIPES</b>	<b>25</b>
<b>F FROM EXTERNAL CORNERS</b>	<b>25</b>
<b>G ABOVE ADJACENT GROUND OR BALCONY LEVEL</b>	<b>25</b>
<b>H FROM A SURFACE FACING THE TERMINAL</b>	<b>600</b>
<b>I FACING TERMINALS</b>	<b>1200</b>
<b>J FROM OPENING (DOOR/WINDOW) IN CAR PORT INTO DWELLING</b>	<b>1200</b>
<b>K VERTICAL FROM A TERMINAL</b>	<b>1500</b>
<b>L HORIZONTALLY FROM A TERMINAL</b>	<b>300</b>
<b>M FROM INTERNAL CORNERS</b>	<b>25</b>

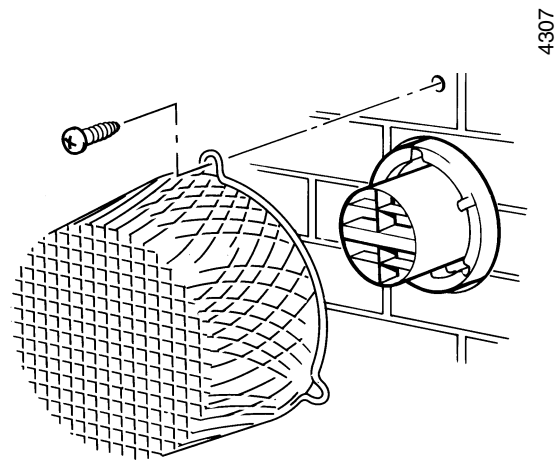

Diagram 2.1

## 3 Water Systems

The installation of the boiler must comply with the requirements of the current issue of BS6798.

It is recommended that plastic pipes for primary pipework should not be used for this boiler.

### 3.1 Frost Protection

If the position of the boiler is such that it may be vulnerable to freezing it should be protected as specified in the current issue of BS5422. It is recommended that a frost protection thermostat be fitted.

### 3.2 Pump

The pump, with integral valves, should be fitted in the heating flow pipework from the boiler, it should be set to produce a temperature difference of 11°C (20°), between the flow and return, with the control thermostat set at "MAX", which is about 82°C (180°F).

The pressure loss of the boiler can be found from diagram 3.1. High resistance microbore systems may require a higher duty pump.

### 3.3 Bypass - Fully Pumped and Sealed Water System

A bypass MUST be fitted to a fully pumped and sealed water system.

Where the water system allows the boiler and pump to operate on bypass only, the bypass connection must be at least 2.5metres away from the boiler.

The flow through the boiler must not be allowed to fall such that there is a temperature difference greater than 20°C between the flow and return.

### 3.4 Water System

For an open vented system the boiler must be supplied from an unrestricted water supply taken from a feed and expansion cistern fitted at a maximum height of 27metres above the boiler.

The cold feed must be 15mm minimum size.

It is important that the relative positions of the pump, cold feed and open vent are as shown in diagram 3.2.

The unrestricted open vent from the boiler must rise continuously to over the feed and expansion cistern.

### 3.5 Domestic Hot Water System

General. The domestic hot water service must be in accordance with the current issue of BS5546, refer also to the current issue of BS6700.

### 3.6 Indirect Cylinder

For all systems supplying domestic hot water the cylinder must be indirect. It is recommended that the indirect cylinder be fitted with some form of temperature control.

### 3.7 Fully Pumped Heating and Domestic Hot Water

The connections for this type of system MUST be as shown in diagram 3.2 and 3.3.

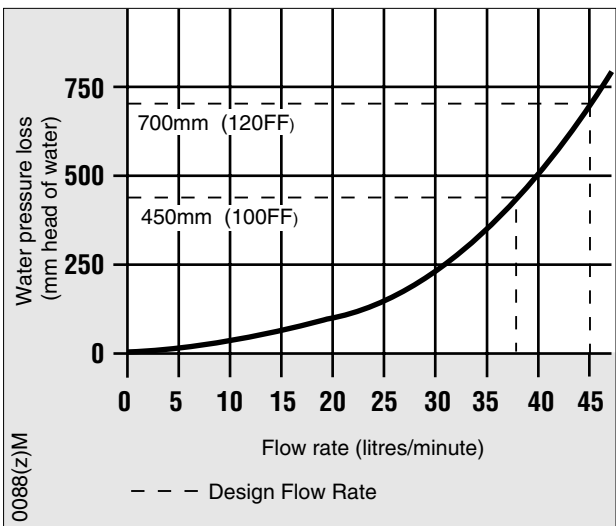

**PRESSURE LOSS OF BOILER 100FF/120FF** Diagram 3.1

### 3.8 Inhibitor

Attention is drawn to the current issue of BS5449 and BS7593 on the use of inhibitors in central heating systems.

If an inhibitor is to be used, contact a manufacturer or Hepworth Heating Ltd., for their recommendations as to the best product to use.

When installing in an existing system take special care to drain the entire system, including the radiators, then thoroughly cleaning out before installing the boiler whether or not adding an inhibitor.

### 3.9 Sealed Water Systems

The installation should comply with the appropriate requirements of the current issue of BS4814, BS5449, BS6759, BS6798 and BS7074 Part 1 and 2, see diagram 3.4 for a suggested layout.

### 3.10 Safety Valve

A safety valve must be fitted to a sealed water system.

It shall be preset, nonadjustable with a lift pressure of 3bar, incorporating seating of resilient material, a test device and a connection for drain.

The drain from the safety valve must be routed clear of any electrical fittings and positioned so that any discharge can be seen.

### 3 Water Systems

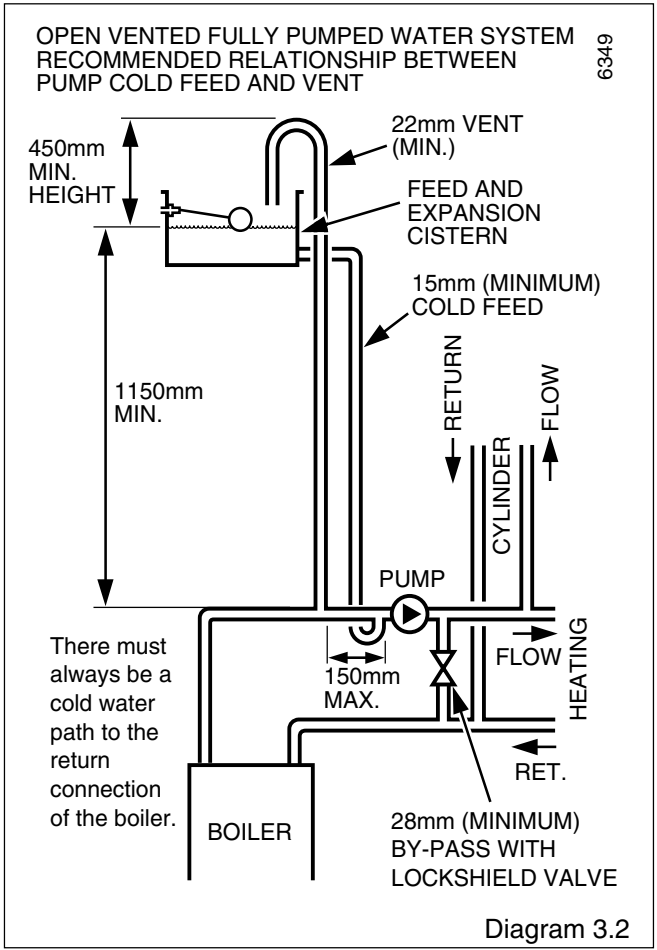

#### 3.11 Expansion Vessel

A diaphragm type expansion vessel, conforming to the current issue of BS4814 (see also BS7074 Part 1 and 2) must be connected at a point close to the inlet side of the circulating pump, see diagram 3.4, unless laid down differently by the manufacturer.

The expansion vessel volume depends upon the total water system volume and the initial system design pressure. For any system an accurate calculation of the vessel size is given in the current issue of BS7074 Part 1.

Example. For an initial system design pressure of 0.7bar the minimum total vessel volume required is 0.063xTotal System volume.

Note. A higher initial design pressure requires a larger volume expansion vessel.

Guidance on vessel sizing is also given in the current issue of BS5449 and BS7074 Part 1.

The charge pressure must not be less than the static head of the system, that is, the height of the highest point of the system above the expansion vessel.

The water content of the boiler is given in Data Table 1.

#### 3.12 Pressure Gauge

A pressure gauge with a set pointer and covering at least the range of 0 to 4bar (0 to 60lb/in<sup>2</sup>) shall be permanently fitted to the system in a position where it can be seen when filling the system.

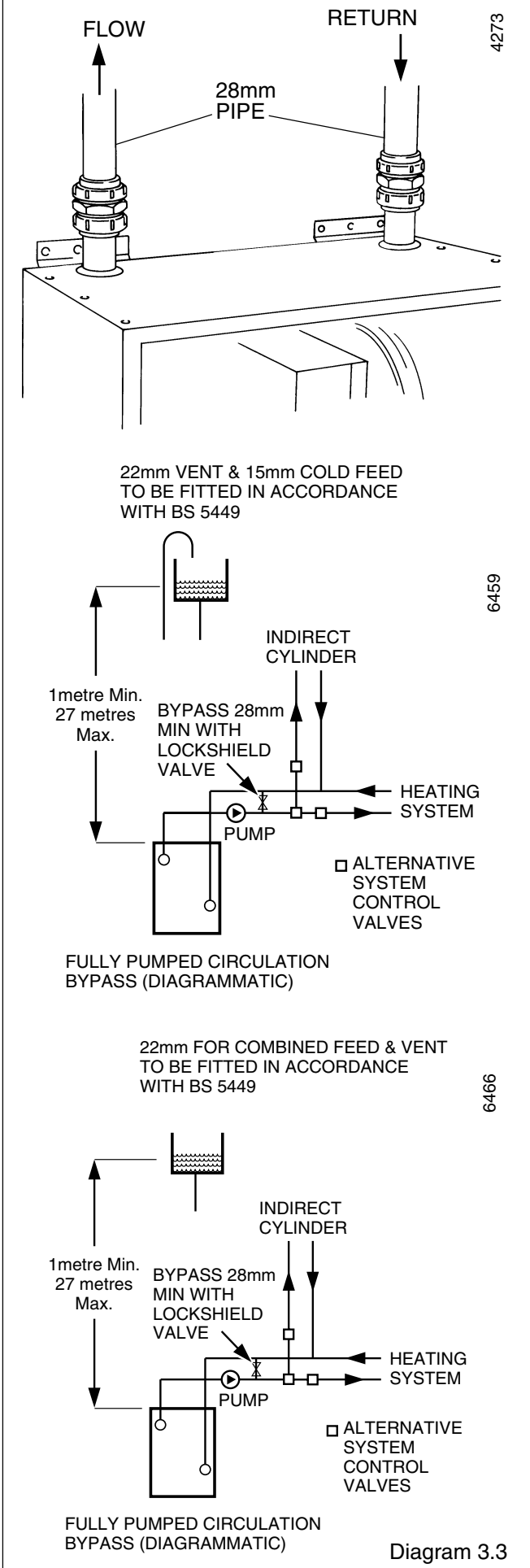

## 3 Water Systems

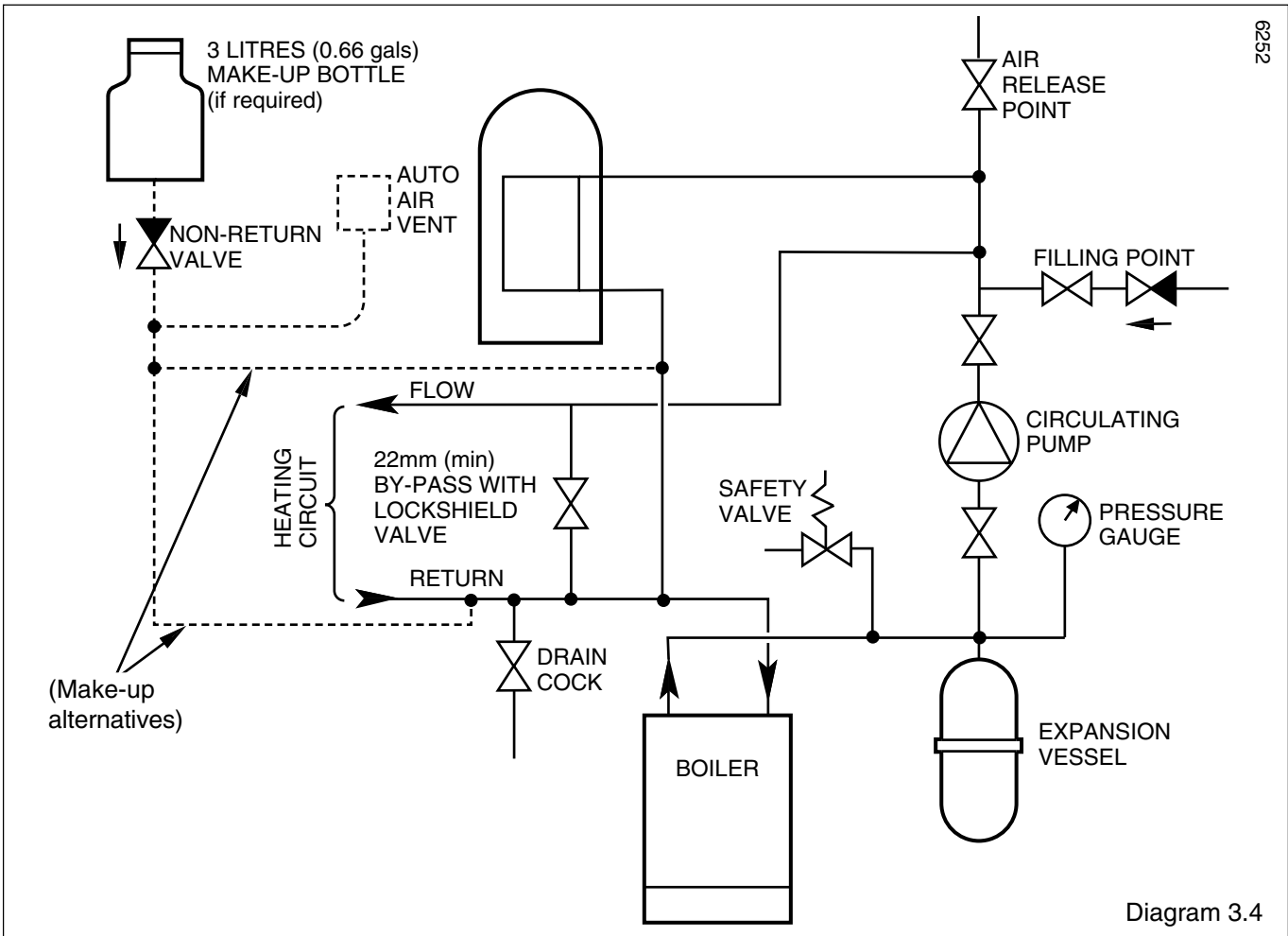

Diagram 3.4

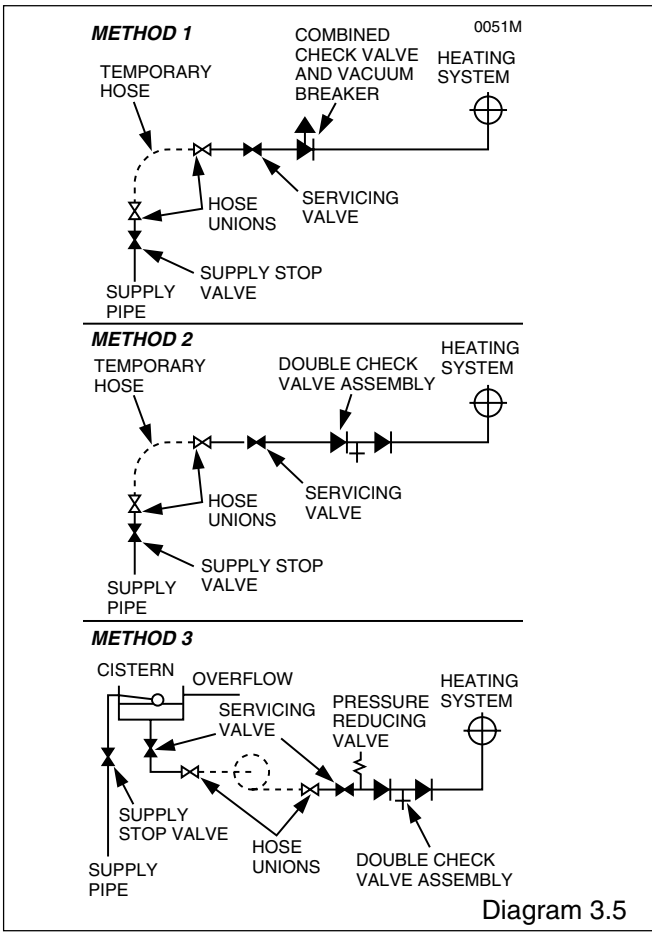

Diagram 3.5

### 3.13 Domestic Hot Water Cylinder

**SINGLE FEED INDIRECT CYLINDERS ARE NOT SUITABLE.**  
 The domestic hot water cylinder must be of the indirect coil type. It must be suitable for working at a gauge pressure of 0.35bar above the safety valve setting.

### 3.14 Domestic Hot Water System - Unvented

Where a storage system will not have a vent to atmosphere the installation must comply with Building Regulations and the Local Water Company Byelaws, see also the current issue of BS6700.

If fitting into an existing system, the local authority must also be advised.

### 3.15 Filling a Sealed Water System

Provision for filling the system at low level must be made. Three methods are shown in diagram 3.5. There must be no permanent connection to the mains water supply, even through a non-return valve.

### 3.16 Water Makeup

Provision must be made for replacing water lost from the system. A make up vessel mounted above the highest point of the system and connected through a non-return valve to the system on the return side of either the hot water cylinder or heating system, see diagram 3.4.

Alternatively provision for make up can be made by a filling loop.

## 4 Flue and Appliance Preparation

### 4.1 Unpacking

Open the carton, check the items supplied against the boiler pack contents list on the flap, see diagram 4.1.

### 4.2 Flue Position and Length

Determine flue applications, length and terminal position before starting.

Refer to diagram 4.2 or 4.3.

Note. If a longer flue duct is required DO NOT extend the ducting.

A 1, 2 or 3 metre flue system and terminal MUST be used, for the 100FF and 1 or 2 metre only for the 120FF.

Note: If required, an optional Wall Liner Kit, part No.452481, is available, complete with fixing instructions.

### 4.3 Flue Preparation

All flue assemblies are designed for internal installation (optional wall liner is required), given that there is sufficient clearances opposite to the flue for the installation of the flue.

If there is insufficient clearance the flue can be installed from outside.

For a wall thickness up to 300mm, provided that there is sufficient space and the optional wall liner kit is used the flue can be fully installed from the inside.

For a wall thickness of over 300mm the external flue hole will need to be made good from the outside. This applies also if you use the flue kit without the optional kit, irrespective of wall thickness.

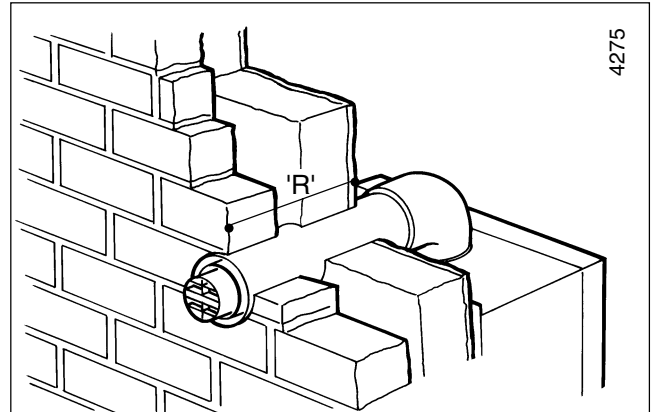
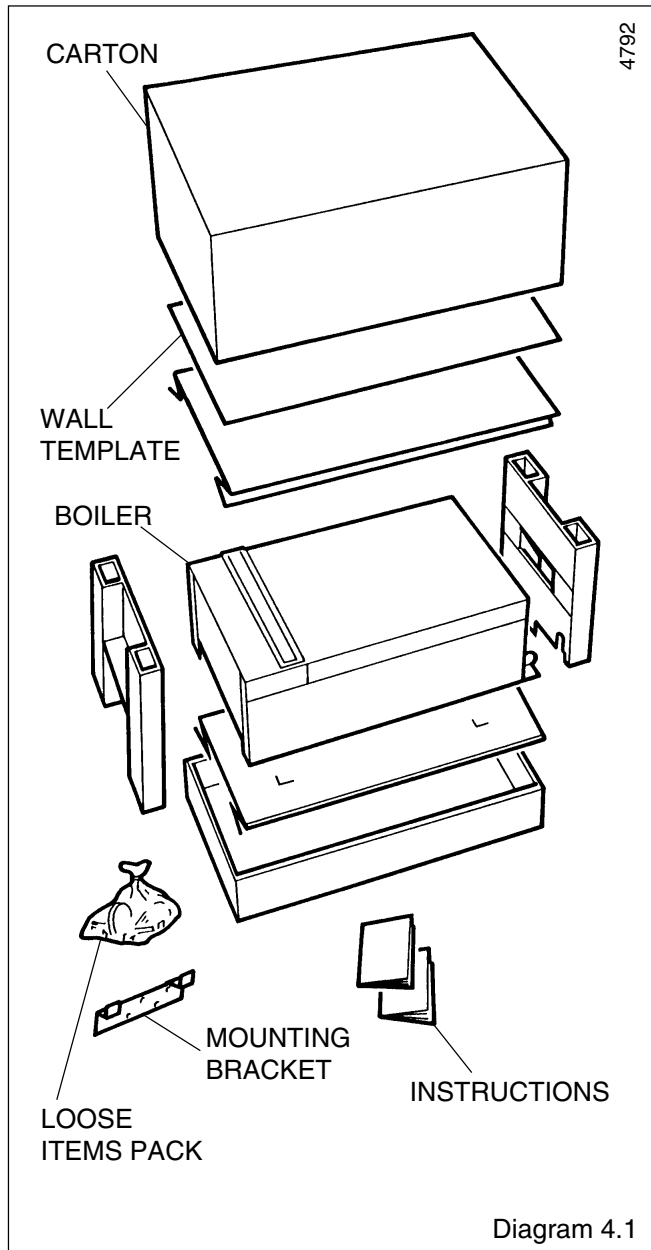

Standard Flue terminal illustrated.

REAR FLUE LENGTHS		
Distance R = Wall thickness		
STD.	75mm to 438mm	
1M	75mm to 928mm	
2M	75mm to 1928mm	
*3M	75mm to 2928mm	*100FF ONLY
Diagram 4.2		

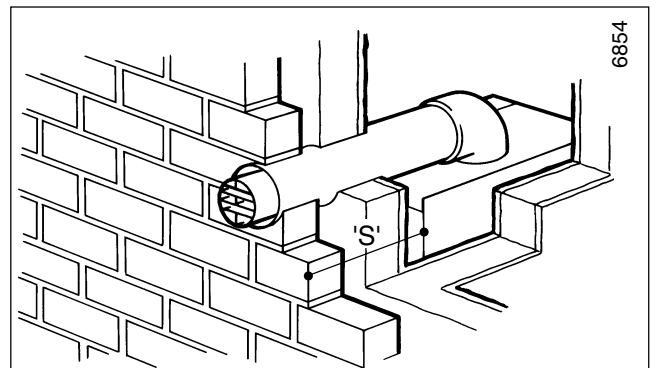

Standard Flue terminal illustrated.

SIDE FLUE LENGTHS		
Distance S = External wall face to boiler case		
STD.	81mm to 346mm	
1M	81mm to 830mm	
2M	81mm to 1830mm	
*3M	81mm to 2830mm	*100FF ONLY
Diagram 4.3		

## 4 Flue and Appliance Preparation

### 4.4. Rear and Side Flue Application

Take the template from the boiler pack and position it on the wall, making sure that the minimum clearances are maintained, see diagram 1.2.

For a rear flue mark the position of the flue as diagram 4.4.

For a side flue, extend the centre line horizontally left or right to the corner of the adjacent surface where the flue is required to exit. Mark the position of the centre of the flue and boiler, then remove template as diagram 4.4.

### 4.5 Flue Hole Cutting

Having marked out the flue centre cut a hole for the flue using, preferably, a 120mm minimum core drill.

### 4.6 Wall Mounting Bracket

Reposition the template, making sure of dimensional alignment with the flue hole.

Mark the boiler fixing points and mounting bracket position, see diagram 4.5.

Note, the mounting bracket has additional holes to allow for further fixings should site conditions require it.

Drill holes and plug, to suit No.12x2in woodscrews, fit the screws allowing sufficient clearance, about 5mm, to accept the swing brackets, see diagram 4.5.

Secure the mounting bracket to the wall with No.12x2in woodscrews and plugs, see diagram 4.5.

If the boiler is not to be fitted for some time, cover the hole in the wall.

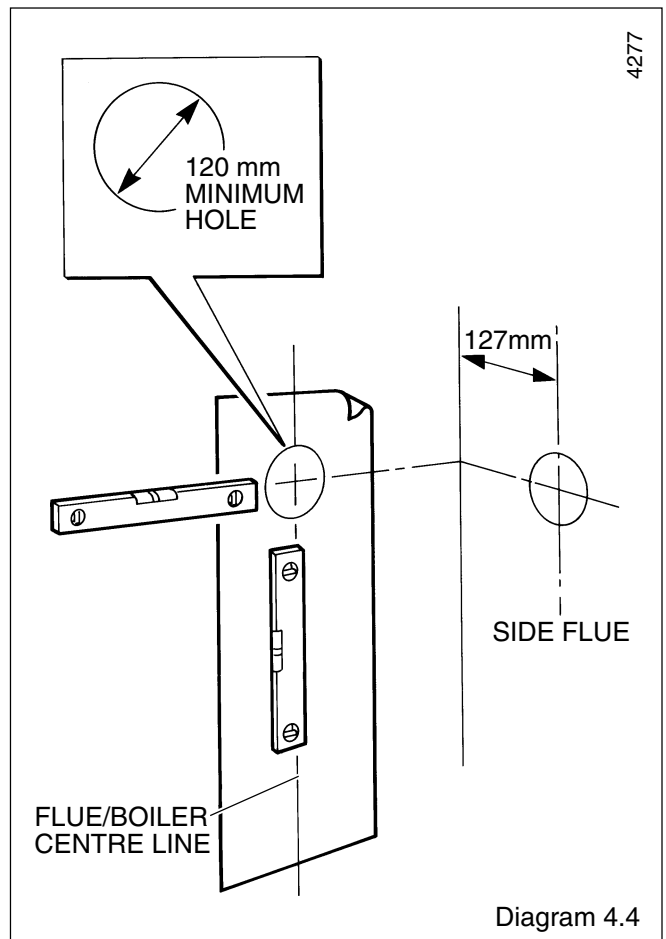

Diagram 4.4

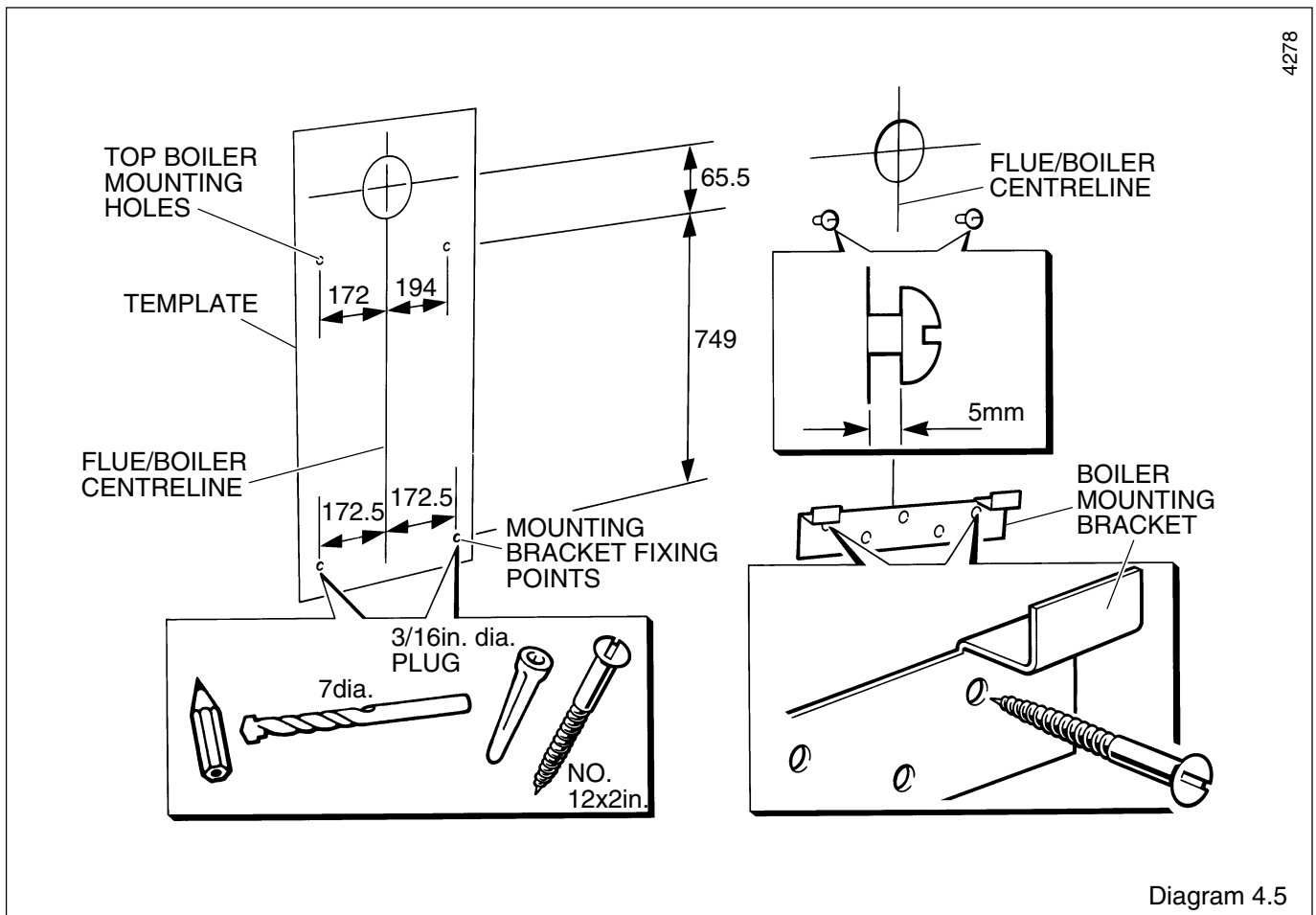

Diagram 4.5

# 4 Flue and Appliance Preparation

## 4.7 Flue Length

For a rear flue, measure the distance from the outside wall face to the boiler mounting wall. Check that the flue length will be suitable, see diagram 4.2.

For a side flue, measure the distance from the outside wall face to the boiler centre line. Check that the flue length will be suitable, see diagram 4.3.

All 2 and 3 metre flue systems are installed in a similar manner to the standard flue.

## 4.8 Rear Flue

Mark the air duct/terminal assembly and the flue duct at the length shown in diagram 4.6 and 4.8 then cut to length, cutting square and removing any burrs.

Note, do not cut the flue duct at the pre-drilled end.

## 4.9 Side Flue

Mark the air duct/terminal assembly and the flue duct at the lengths shown in diagram 4.7 and 4.9 then cut to length, cutting square and removing any burrs.

Note, do not cut the flue duct at the pre-drilled end.

## 4.10 Flue Assembly

Locate the flue duct (drilled end) onto the flue elbow and secure with the screws supplied in the loose items pack, see diagram 4.10.

Locate the flue duct/elbow into the air duct/terminal spigot and the air duct/terminal into the flue elbow making sure the correct alignment of top. Drill the air duct and secure/seal (external fixing, do not seal) as shown in diagram 4.10.

## 4.11 Wall Liner

If a wall liner is used, fit foam seal as diagram 4.11.

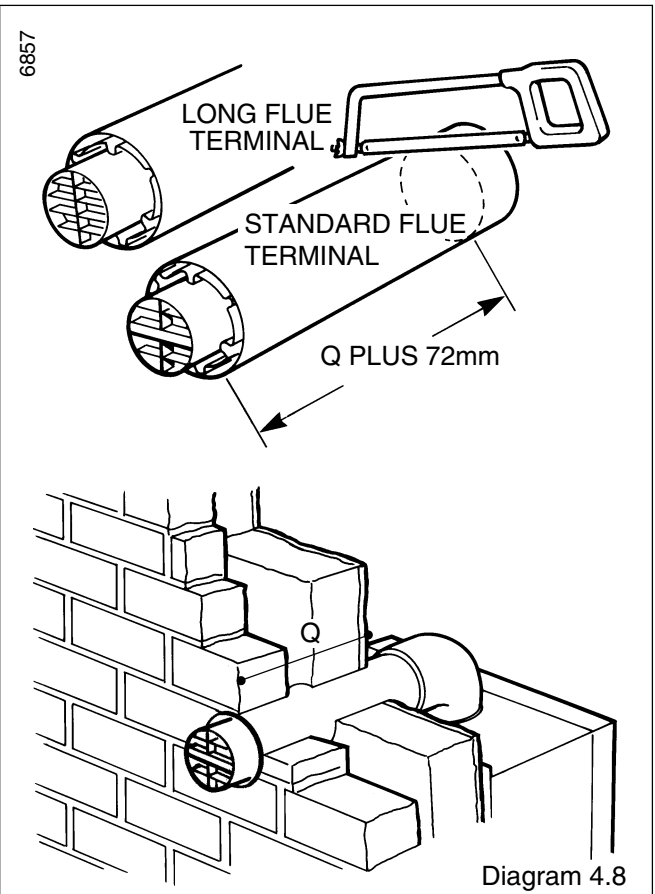
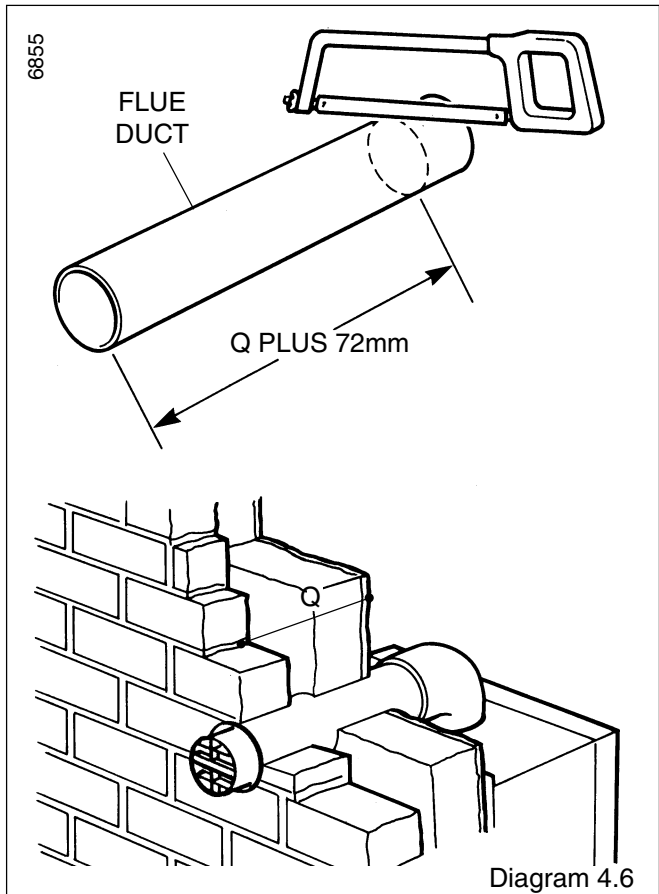
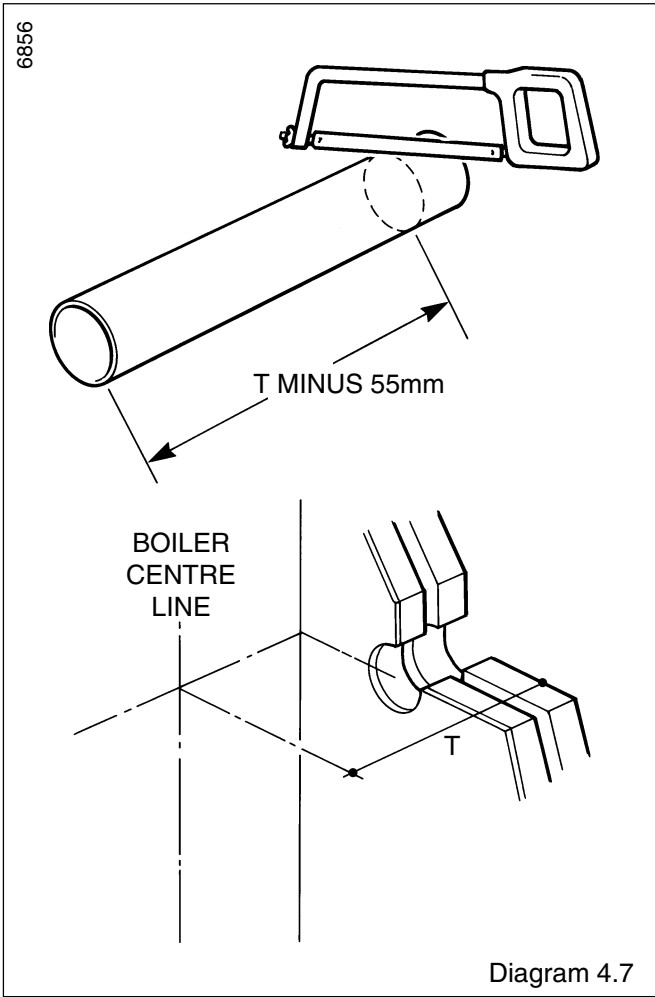

### 4 Flue and Appliance Preparation

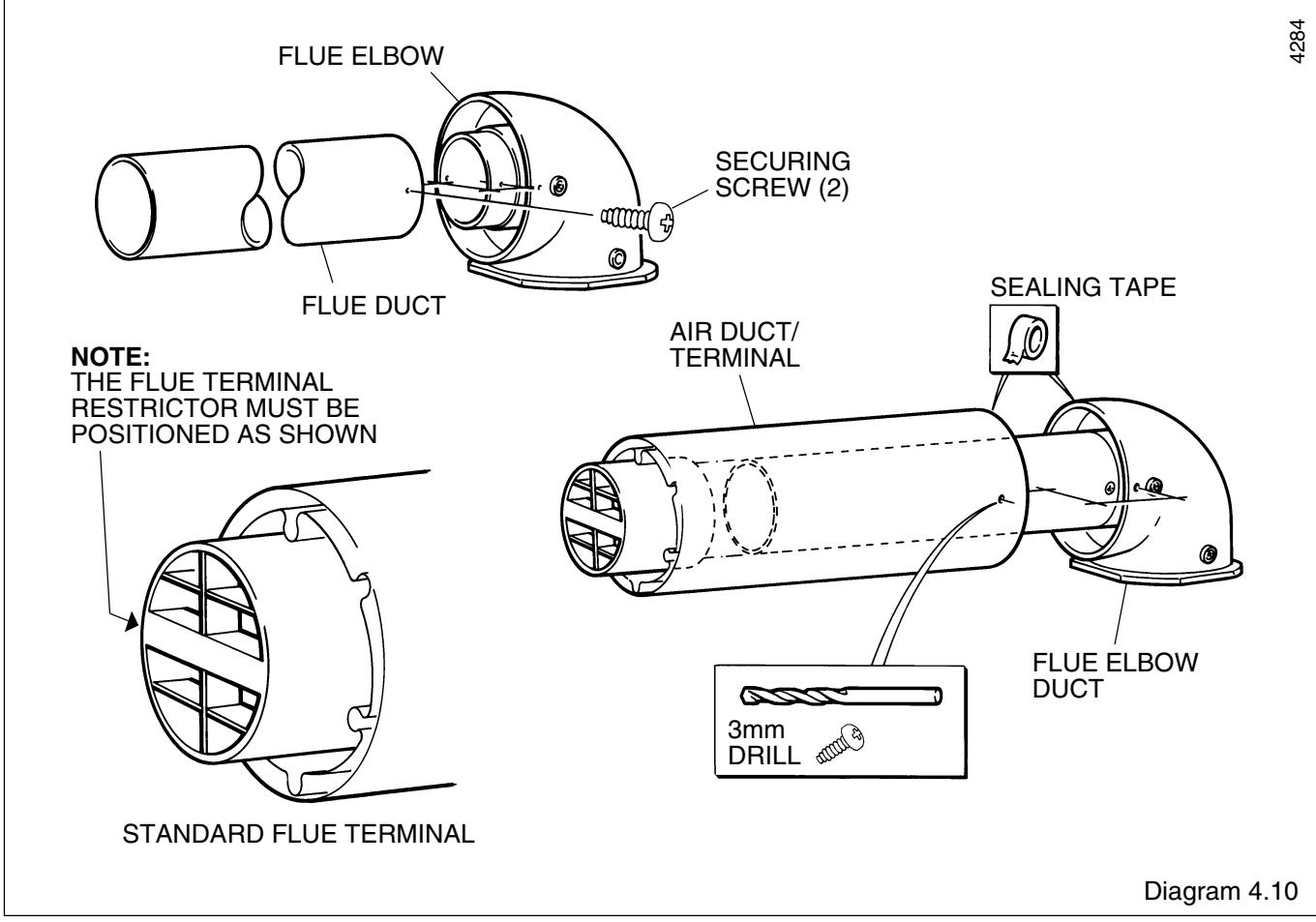
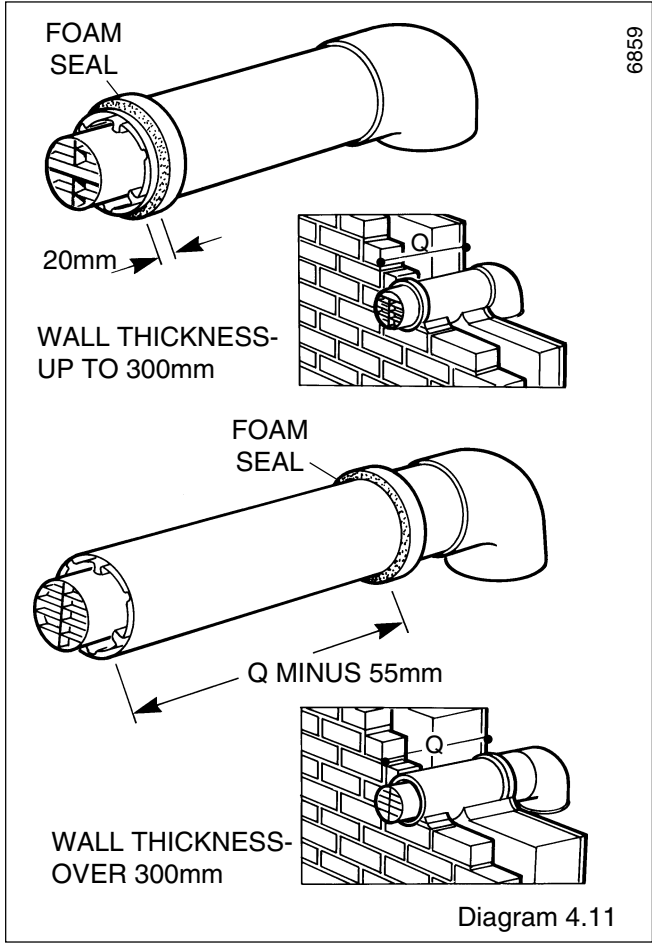
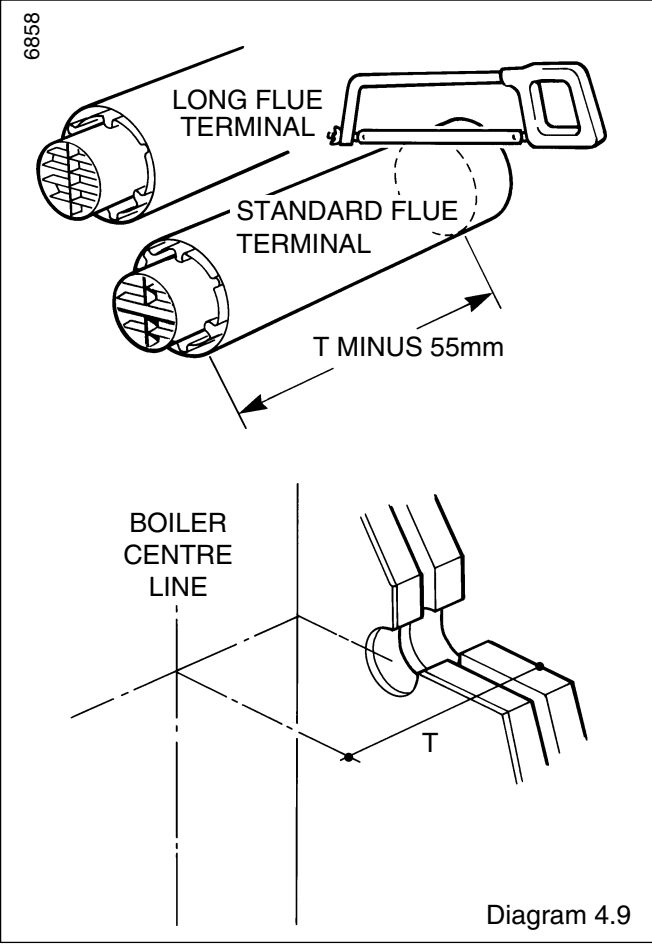

# 5 Boiler Installation

## 5.1 Boiler Preparation

With the boiler still in the bottom tray, slide the controls cover upwards and remove it as shown in diagram 5.1.

Remove the front cover by undoing (and keeping) the wing nut, nut and shakeproof washer, then lift the front cover off, see diagram 5.1.

Place the front cover on one side until required, having removed the polystyrene packing piece.

Fit suitable compression fittings to the boiler connections.

## 5.2 Mounting the Boiler

Make sure that the top, swing brackets are UPRIGHT.

Lift the boiler into position, hooking over the mounting bracket.

Swing the brackets over the two screws at the top. Hold the swing bracket(s) in place whilst tightening the screw(s) on to it, see diagram 5.2.

Remove the blue and red electrical connections from the fan, see diagram 5.3.

Break the air pressure switch tube connections from the fan, see diagram 5.3.

Remove the fan assembly by removing the screws and sliding out, see diagram 5.3. Take care not to damage the gasket.

Slacken, but do not remove, the flue hood securing screws, see diagram 5.4.

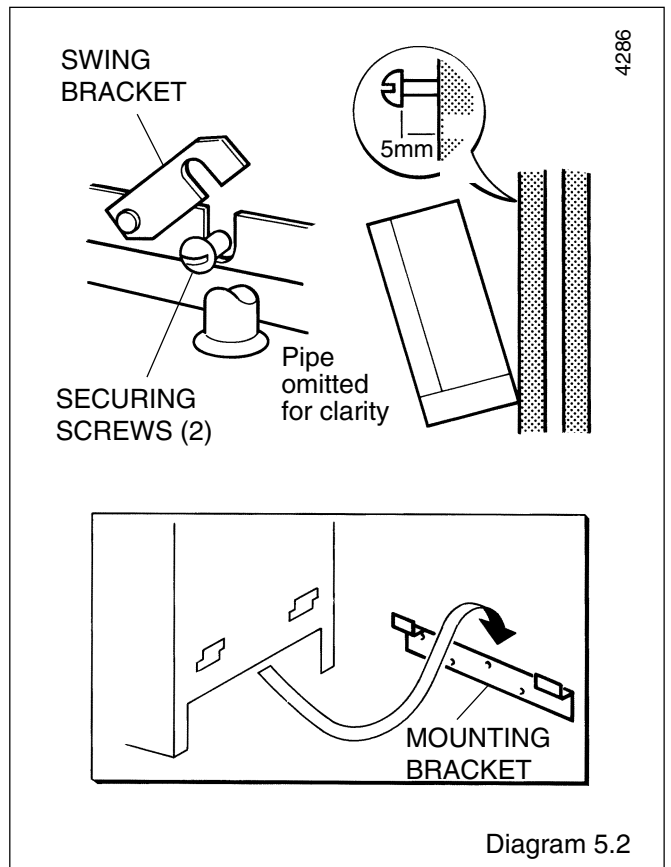
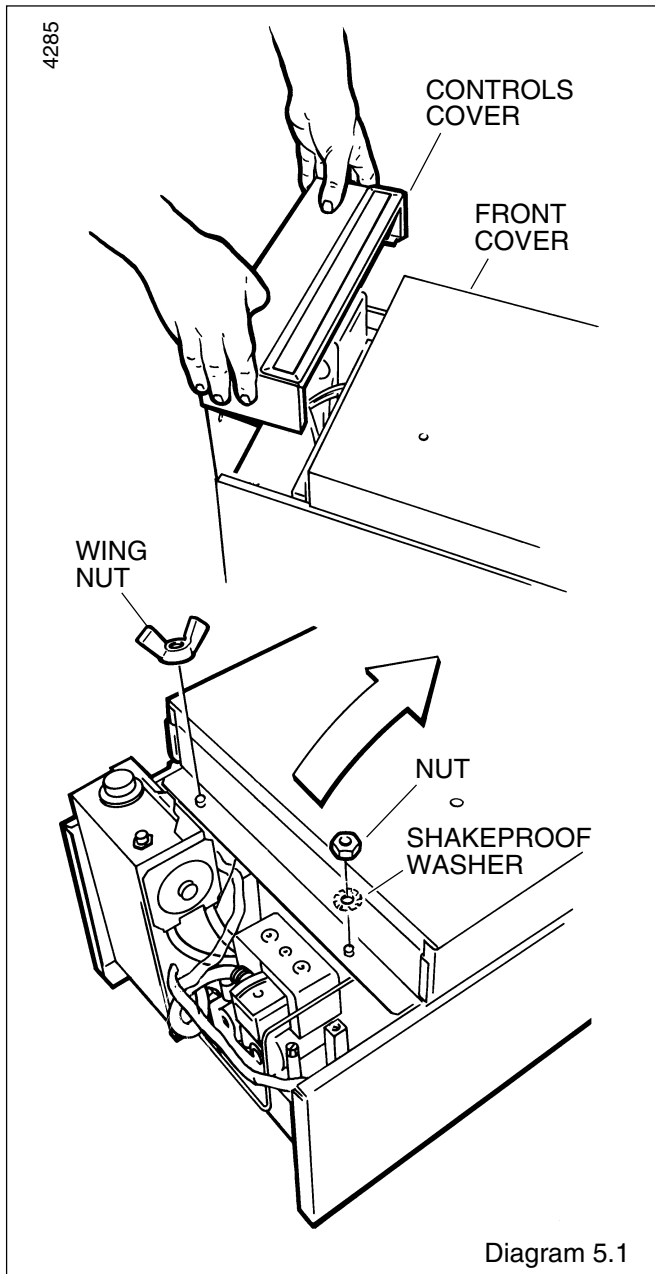

# 5 Boiler Installation

## 5.3 Water Circulation System

Complete the water connections to the boiler.

Fill, vent and flush system.

Check for any leaks and put right.

## 5.4 Safety Valve Discharge

Fit a suitable discharge pipe to the safety valve and route it outside the building so that any discharge can be seen but will not cause injury to person, damage to property or any electrical installation.

## 5.5 Gas Connection

Make the gas connection to the Rc 1/2 in gas service cock, see diagram 5.5.

Check for leaks using a suitable leak detection fluid.

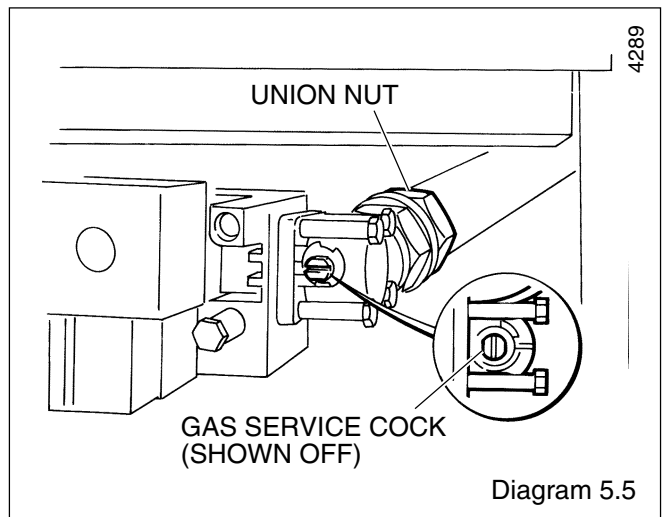
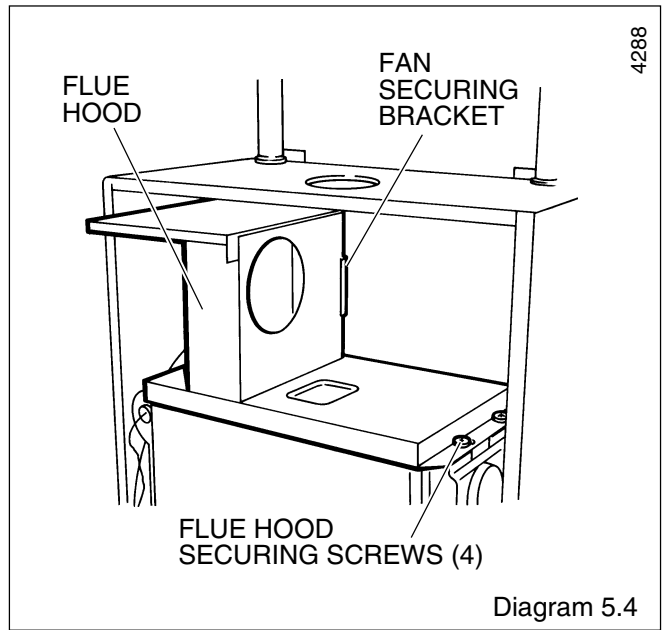
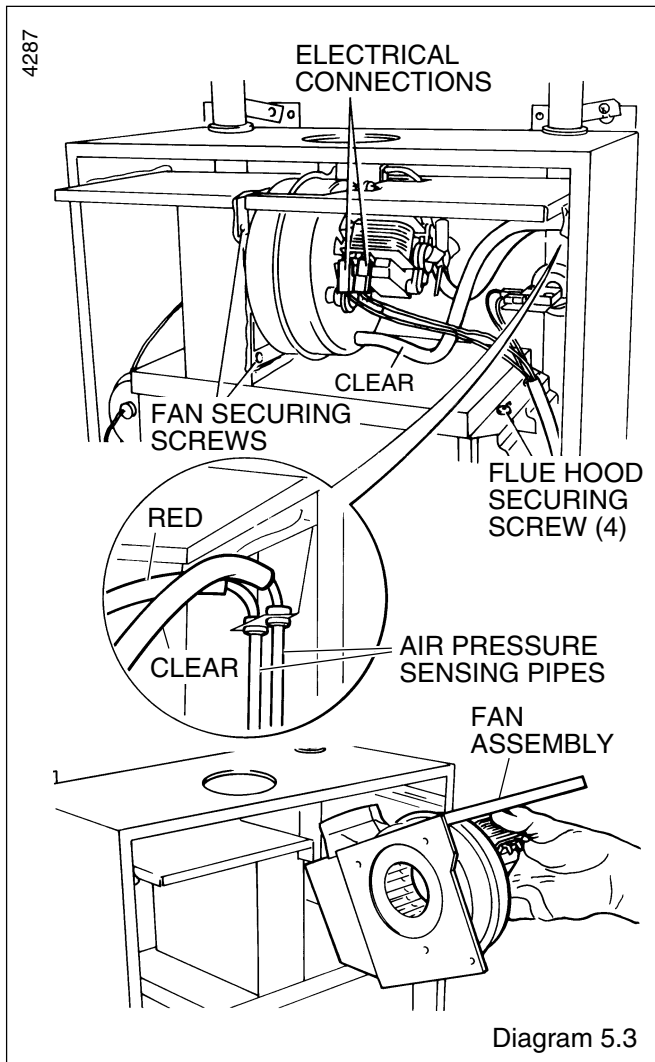

## 6 Flue Fixing

Note. If external flue fixing is required start at 6.2.

### 6.1 Flue Fixing - Internal

Note : Use of the optional wall liner kit is required.  
 Place the flue assembly into the hole. Check that the flue terminal is correctly positioned and is the distance required from the outside wall face, see diagram 6.1.  
 Position flue elbow gasket and secure the flue assembly to the boiler using the dogpoint screws, see diagram 6.2.  
 Make sure of the correct fitting of the flue to the boiler.  
 Now continue at Section 6.3.

### 6.2 Flue Fixing - External

Remove the flue elbow from the air duct/terminal and flue duct, by removing and keeping, the securing screw(s).  
 From outside place the air duct/terminal and flue duct assembly into the hole and make sure that the flue terminal is correctly positioned and is the distance required from outside wall face, see diagram 6.1.  
 Position flue elbow gasket and secure the flue elbow to the boiler using the dogpoint screws, see diagram 6.2.  
 Make sure of the correct fitting of the flue to the boiler.  
 Pull the flue duct forwards and engage onto the flue elbow.  
 Push the air duct back into the wall to the dimension shown in diagram 6.3.  
 Important, the flue duct will become disengaged should the dimension be any greater than shown.  
 Hold the flue duct onto the flue elbow, then, secure the flue duct to the flue elbow, see diagram 6.3.  
 Pull the air duct back to engage with the flue elbow and secure/seal.

### 6.3 All Flue Installations

Fit the fan to the flue elbow spigot and secure with the screws previously removed.  
 Reconnect the blue and red electrical connections to the fan, the polarity of the connections is not important.  
 Reconnect the air pressure switch tubes as shown in diagram 5.3.  
 Secure the flue hood, see diagram 5.4.

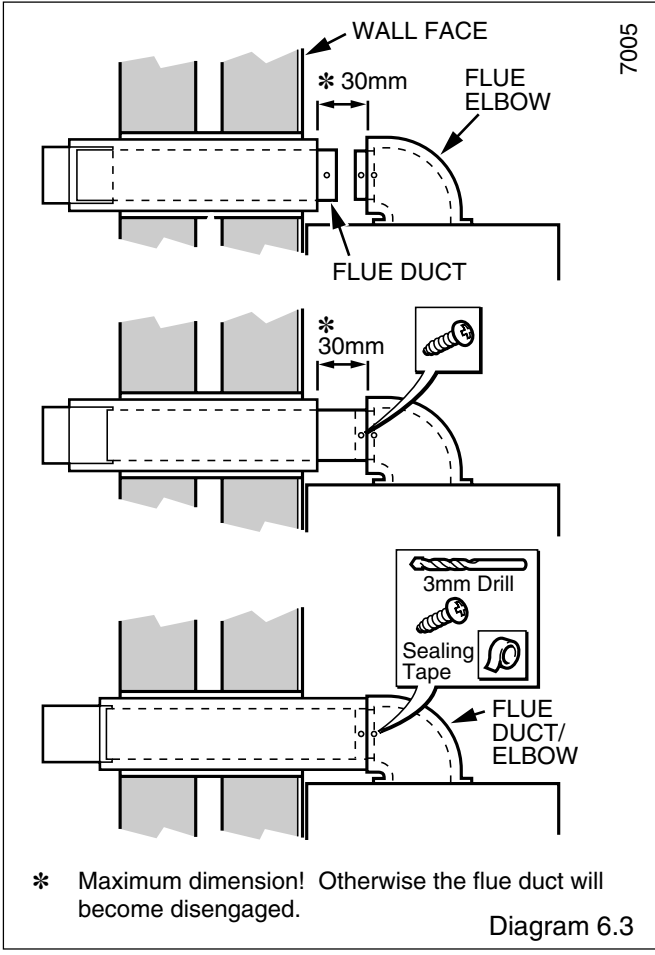
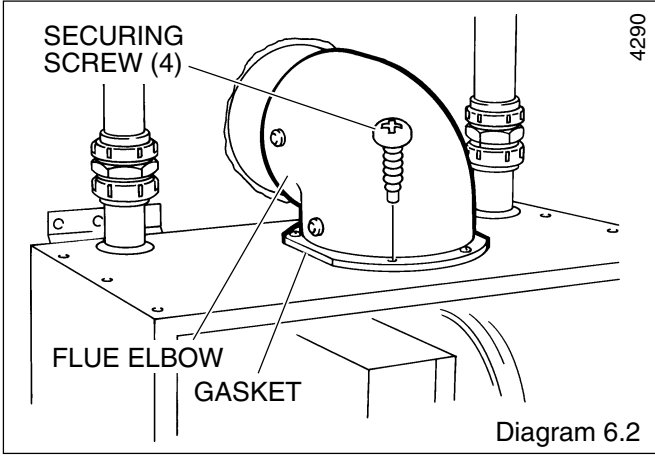
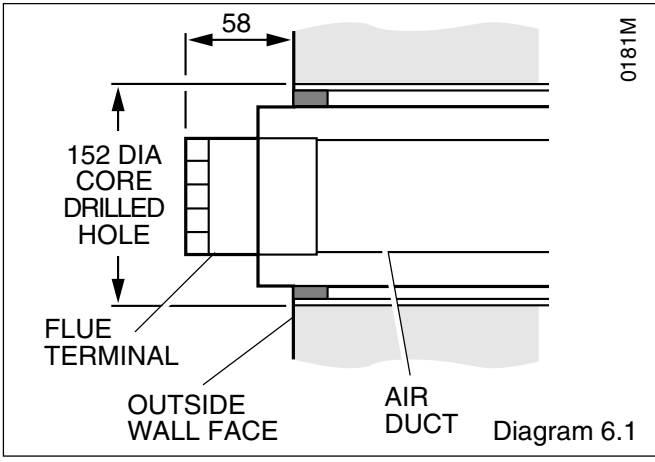

# 7 Electrical Connectors

## 7.1 Control Box Removal

Remove the electrical control box securing screws, see diagram 7.1. Slide the box forwards and release, hook it onto the lip bracket at the front, see diagram 7.1.

## 7.2 Electrical Connection

**WARNING.** This boiler must be earthed.  
Take care not to damage any internal wiring and capillaries.  
Take the plastic cable retaining clip, from the loose items pack, peel off the backing paper and position it in a suitable place to secure the incoming cable.

Using heat resistant (to 85°C) cable of at least 0.75mm<sup>2</sup> (24/0.2mm) to the current issue of BS6500 Table 16 and of suitable length, thread through the cable clamps, secure into the plastic clips and connect to appropriate terminals, see diagram 7.2 and 11.5.

Standard colours are, brown - live (L), blue - neutral (N) and green and yellow - earth (E).

Make sure the cable is suitably secured.  
When making connections, make sure that the earth conductor is made of a greater length than the current carrying conductors, so that if the cable is strained the earth conductor would be the last to become disconnected.

**NOTE.** Open Vented Water Systems ONLY.  
Bridge terminals K1 and K2.

## 7.3 Pump Connection

The pump must be connected directly to the control box, as shown in diagram 7.2, threading the cable through the cable clamp in the side of the control box.

## 7.4 External Controls

Any external controls must only be wired to interrupt the red link between terminals SL and 9.  
Make sure that the supply cable and all external cables are secured and away from hot surfaces.

## 7.5 Testing

Checks to ensure electrical safety must be carried out by a competent person.  
After installation of the system, preliminary electrical system checks as below should be carried out:

1. Test insulation resistance to earth.
2. Test earth continuity and short circuit of all cables.
3. Test the polarity of the mains.

The installer is requested to advise and give guidance to the user of the controls scheme used with the boiler.

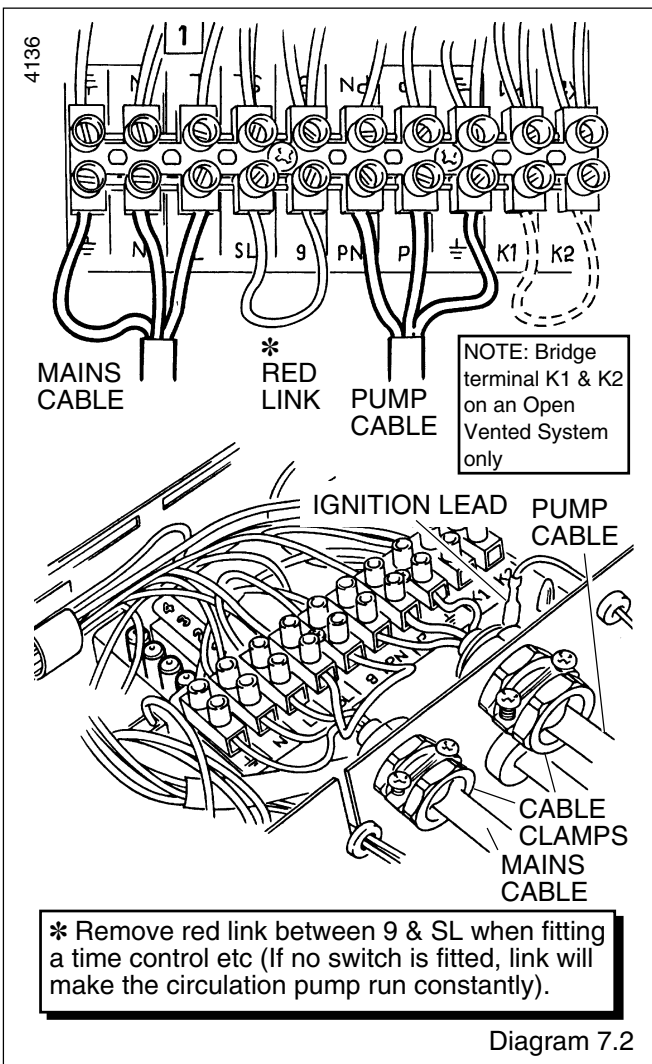
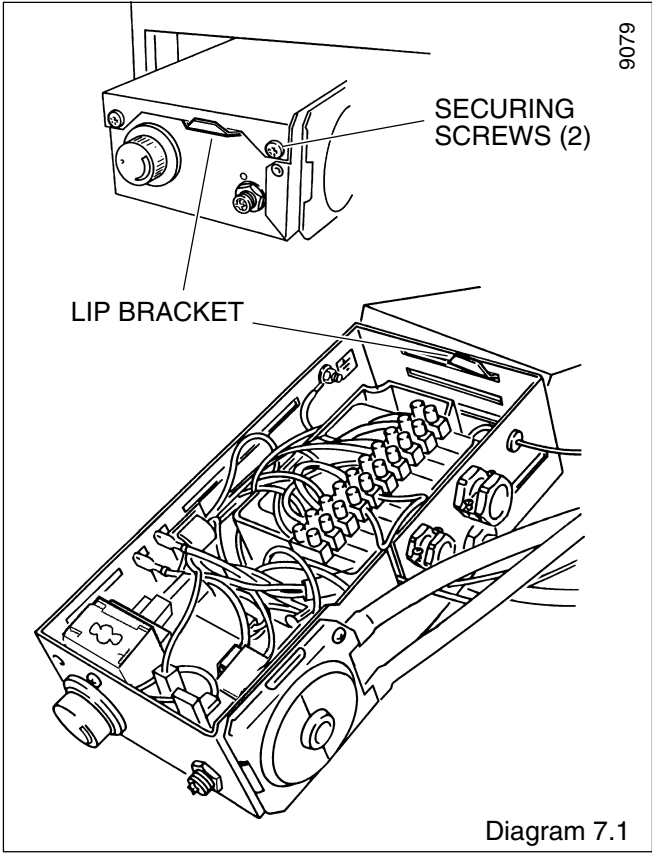

# 8 Commissioning

Please ensure the "Benchmark" logbook is completed and left with the user.

## 8.1 All Systems

Commissioning should be carried out by a competent person in accordance with the current issue of BS6798.

Make sure that the system has been thoroughly flushed out with cold water without the pump in place.

Refit the pump, fill the system with water, making sure that all the air is properly vented from the system and pump.

Before operating the boiler check that all external controls are calling for heat.

## 8.2 Sealed Water Systems Only

Flush the whole system with cold water without the pump in place. Refit the pump and fill until the pressure gauge registers 2.7bar (40lbf/in<sup>2</sup>). Clear any air locks and check for water soundness.

Check the operation of the safety valve, by allowing the water pressure to rise until the valve opens. The valve should open within +/-0.3bar (+/-4.3lbf/in<sup>2</sup>) of the preset pressure. Where this is not possible conduct a manual check and test.

Release cold water to initial system design pressure.

The set pointer on the pressure gauge should be set to coincide with the indicating pointer.

## 8.3 Initial Lighting and Testing

**CAUTION.** This work must be carried out by a competent person, in accordance with the current issue of BS6798.

Make sure that all naked lights and cigarettes are out.

Identify the controls by reference to diagram 8.1.

Check that the boiler is isolated from the electrical supply.

Make sure that the control thermostat is turned to "O" the "Off" position.

Turn boiler gas service cock "On".

Test the pilot supply tube and its connection for gas soundness as follows:

Disconnect the ignition lead from the PCB, see diagram 7.2.

Remove the combustion chamber front, see diagram 8.2.

**WARNING.** The fan operates on mains voltage, terminals will become live.

Turn the electrical supply on and check that all remote controls are calling for heat.

Check that the pump is circulating water through the system.

To complete the test it is necessary to operate the boiler without its case, but **UNDER ALL OTHER CIRCUMSTANCES** the case must be correctly fitted and sealed.

Turn the control thermostat knob fully clockwise and the fan will work.

Note. There will be no sparks at the pilot. Take care and light the pilot with a match.

Test the pilot supply and connections for gas soundness, using a suitable leak detection fluid.

Very cold weather may delay the operating sequence.

The pilot rate is preset and must not be adjusted.

The step adjustment screw must not be touched.

The pilot flame length should be as shown in diagram 8.3.

Turn the control thermostat knob to "O" and isolate the boiler from the electrical supply.

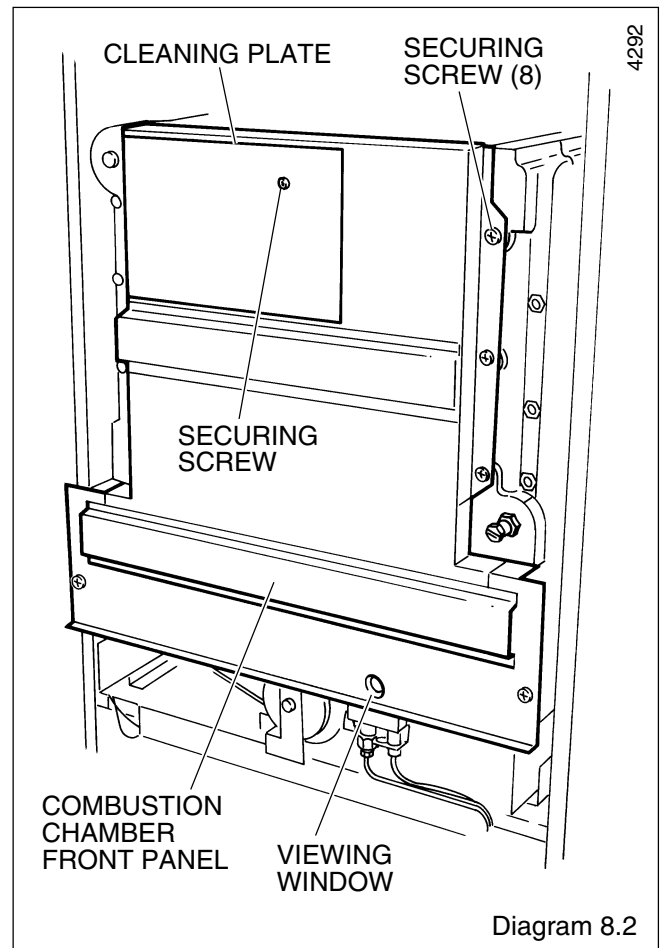
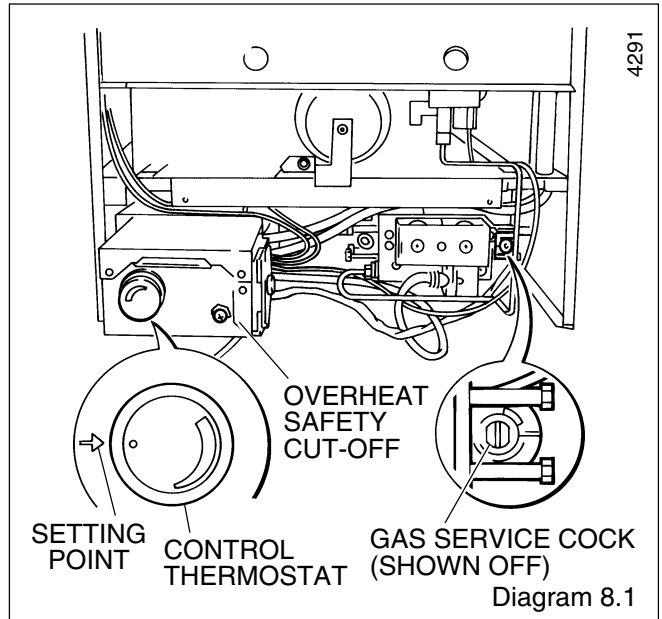

## 8 Commissioning

Fit the combustion chamber front.

Reconnect the ignition lead to the PCB.

For future reference, stick the self adhesive arrow indicator to the data label, against the rating that the boiler is going to be set to. The arrow is in the loose items pack.

Loosen the main burner pressure test point screw and connect a suitable pressure gauge, see diagram 8.4.

Make sure that any remote controls are calling for heat.

Switch on/connect the electrical supply to the boiler and heating system, neon 1 will light.

### 8.4 Testing - Electrical

Turn the control thermostat knob fully clockwise to the maximum setting, which is about 82°C (180°F), neon 2 will light.

The lighting sequence is automatic as follows:

- |  |   |                   |
|--|---|-------------------|
| The fan operates<br>The Spark ignition operates<br>The pilot solenoid opens<br>The pilot burner lights | } | Neon 3 will light |
| The ignition spark stops<br>The main solenoid opens  | } | Neon 4 will light |

and after a short period of time the main burner will light, look through viewing window, see diagram 8.2.

The main burner will stay alight until switched off, either by the control thermostat or a remote system control.

To make sure that the flame supervision device is working correctly the following should be done:

Very cold weather may delay the operating sequence.

1. With the main burner alight, turn the gas service cock "Off", see diagram 8.1.

After a short period the main burner and pilot will go out.

2. The correct working of the flame supervision device is shown by neon 4 going out within 10 seconds and the ignition starting up.

Neons 1, 2, and 3 should stay alight.

3. If the above does not happen, refer to fault finding Section 11.1.

4. To carry on turn the gas service cock "On", see diagram 8.1.

When the boiler switches "Off", both the pilot and the main burner go out. The automatic lighting sequence will work again when heat is required.

### 8.5 Testing - Gas

With the boiler on proceed as follows:

Test for gas soundness around the boiler gas components using a suitable leak detection fluid, in accordance with the current issue of BS6891.

Check the main burner gas pressure at least 10 minutes after the boiler has lit, refer to Data Label.

If necessary adjust the gas pressure to obtain the required setting turning the screw clockwise, to decrease pressure, see diagram 8.4.

Should any doubt exist about the gas rate, check it using the gas meter test dial and stop watch, at least 10 minutes after the burner has lit, making sure that all other gas burning appliances and pilot lights are off.

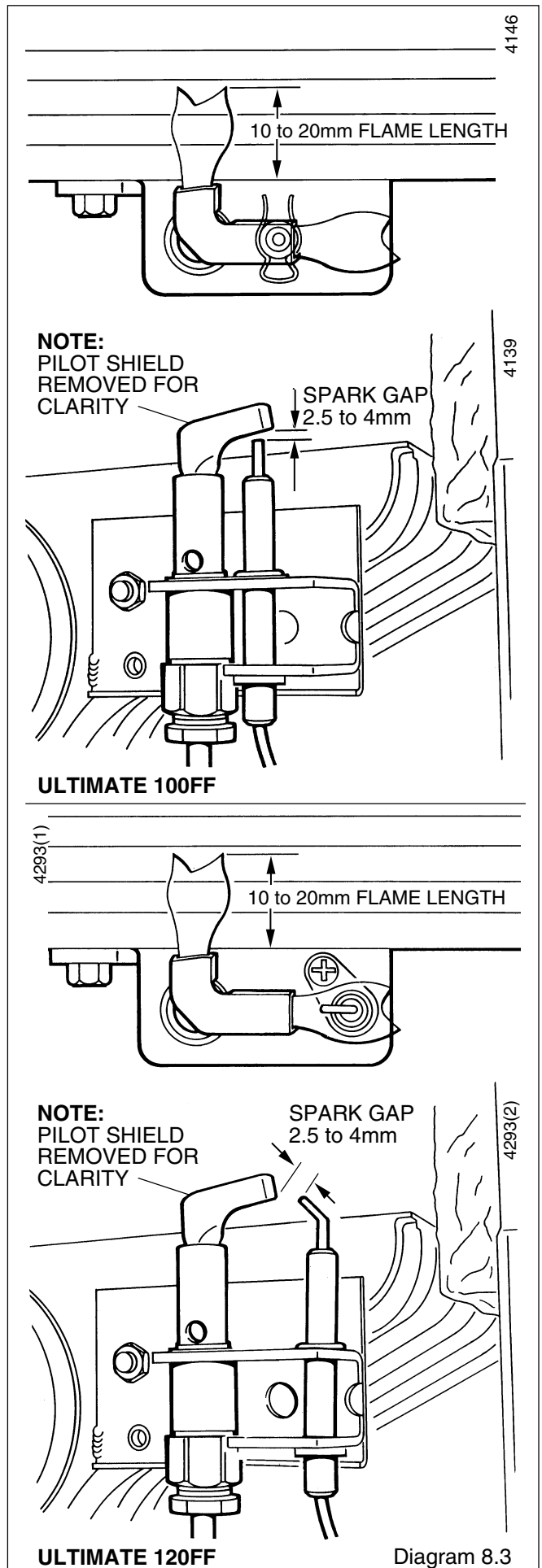

# 8 Commissioning

Turn the control thermostat knob fully anticlockwise to "O". Remove the pressure gauge from the test point and refit screw, making sure a gas tight seal is made.

When the control thermostat is turned to "Off" position, by hand, wait at least 30 seconds before turning "On" again.

There may be an initial smell given off from the boiler, this is quite normal and will disappear after a short period of time.

Refit the electrical controls box, see diagram 7.1.

Note. The neon indicators on the printed circuit board are an aid to fault finding, for details refer to Section 11.

## 8.6 Testing - Open Vented

Allow the system to reach maximum working temperature and examine for water leaks.

There should be no undue noise in the system and no pumping over of water or entry of air at the open vent above the feed and expansion cistern.

All systems. The boiler should be turned off and the system drained off as rapidly as possible, whilst still hot.

## 8.7 Adjustment - Fully Pumped Open Vented and Sealed Water Systems

When commissioning the system the boiler should first be fired with the bypass fully closed on full service, that is, central heating and domestic hot water. Adjust the pump to the system design setting then balance the system. Having achieved a satisfactory condition operate the boiler with the bypass fully closed on minimum load, normally this will be central heating only with one radiator in the main living area operating. The bypass valve should be gradually opened to achieve a temperature difference no greater than 20°C between the flow and return.

**UNDER NO CIRCUMSTANCES SHOULD THIS VALVE BE LEFT IN THE FULLY CLOSED POSITION.**

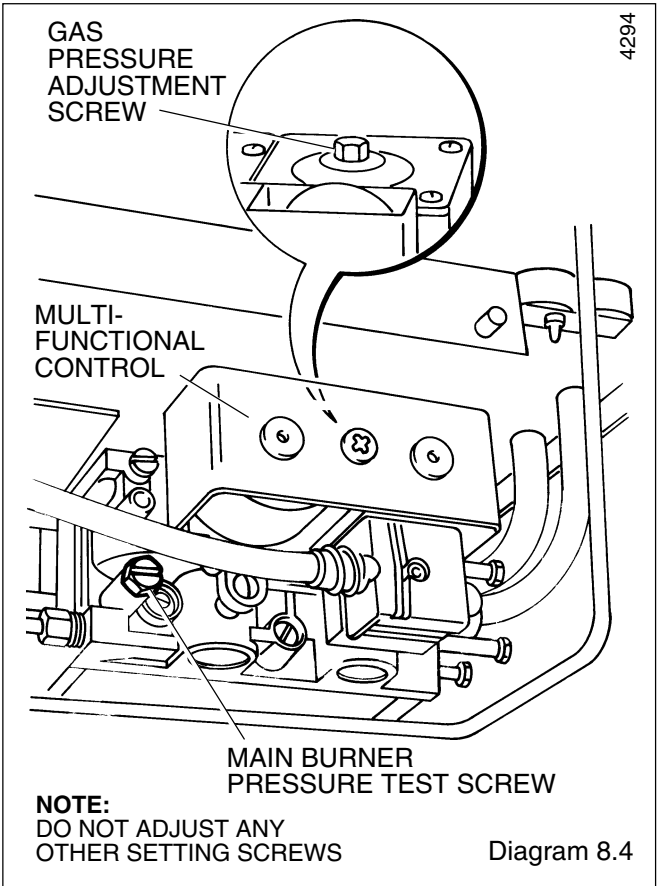

## 8.8 Sealed Water System ONLY

Adjust system to initial design pressure. The set pointer on the pressure gauge should be set to coincide with the indicating pointer.

## 8.9 Thermostatic Radiator Valves

If thermostatic radiator valves are fitted care must be taken to ensure that an adequate flow rate through the boiler when they close, refer to the current issue of BS7478 for guidance.

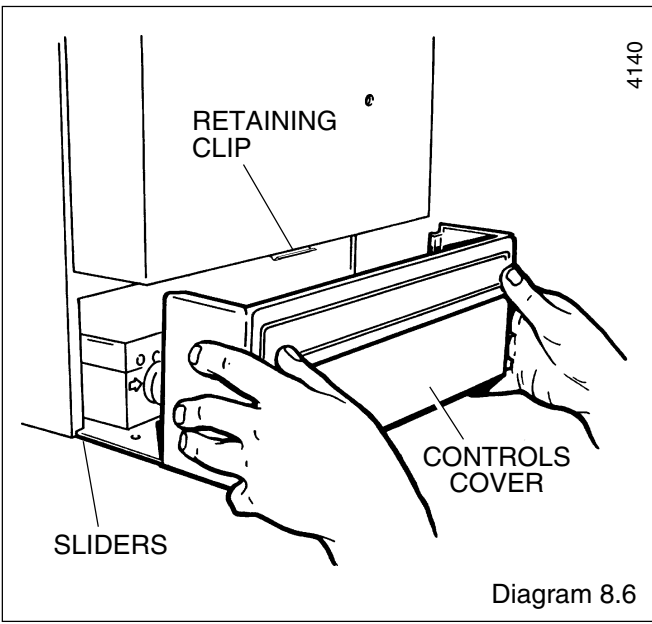
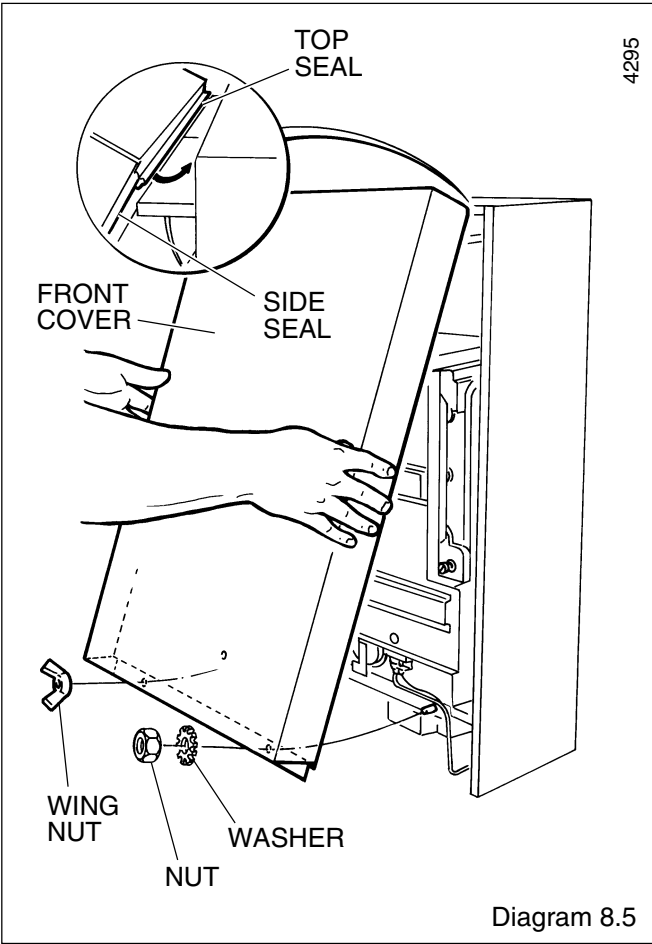

## 8 Commissioning

### 8.10 Operational Checks and Completion

Adjust the control thermostat and any system controls to their required settings.

Do not attempt to adjust the thermostat calibration screw.

Operate the boiler again on full service and check that the balancing is satisfactory, making adjustments as necessary.

Fit the front cover by hooking it under at the top and securing with the screws previously removed, see diagram 8.5.

Fit the controls cover by hooking into the sliders and pushing it back as far as it will go, see diagram 8.6.

### 8.11 Protection against Freezing

If the boiler is to be out of use for a period of time during severe weather conditions we recommended that the whole of the system, including the boiler, be drained off to avoid the risk of freezing up.

## 9 Instructions to the User

Instruct and demonstrate the safe and efficient operation of the boiler, heating system and domestic hot water system.

Advise the user, that to ensure the continued efficient and safe operation of the boiler it is recommended that it is checked and serviced at regular intervals. The frequency of servicing will depend upon the particular installation and usage, but in general once a year should be enough.

Draw attention, if applicable, to the current issue of the Gas Safety (Installation and Use) Regulations, Section 35, which imposes a duty of care on all persons who let out any property containing a gas appliance.

It is the Law that servicing is carried out by a competent person.

Advise the user of the precautions necessary to prevent damage to the system and the building in the event of the heating system being out of use during frost and freezing conditions.

Reminder, leave these instructions and the 'Benchmark' logbook with the user.

## 10 Servicing

**REMEMBER**, When replacing a part on this appliance, use only spare parts that you can be assured conform to the safety and performance specification that we require. Do not use reconditioned or copy parts that have not been clearly authorised by Hepworth Heating Ltd

**Notes.** To ensure the continued efficient and safe operation of the boiler it is recommended that it is checked and serviced as necessary at regular intervals. The frequency of servicing will depend upon the particular installation conditions and usage, but in general once a year should be enough.

It is the Law that any servicing is carried out by a competent person.

Before servicing turn off the gas and isolate the electrical supply to the boiler.

After completing a service always test for gas soundness and carry out functional check on controls.

Unless stated otherwise all parts are replaced in the reverse order to removal.

### 10.1 Access

Refer to diagram 8.6 and slide controls cover forward and off.

Remove the outer case, see diagram 8.5.

**Note.** As an aid to servicing the air pressure switch tube connections can be used to obtain a products of combustion reading.

Remove the RED tube from the connection on the air pressure switch and insert the analyser probe into the tube.

Switch on the electrical supply to operate the fan and turn on the gas supply.

On completion of the test switch off the electrical supply and the gas supply and reconnect the red tube to the air pressure switch.

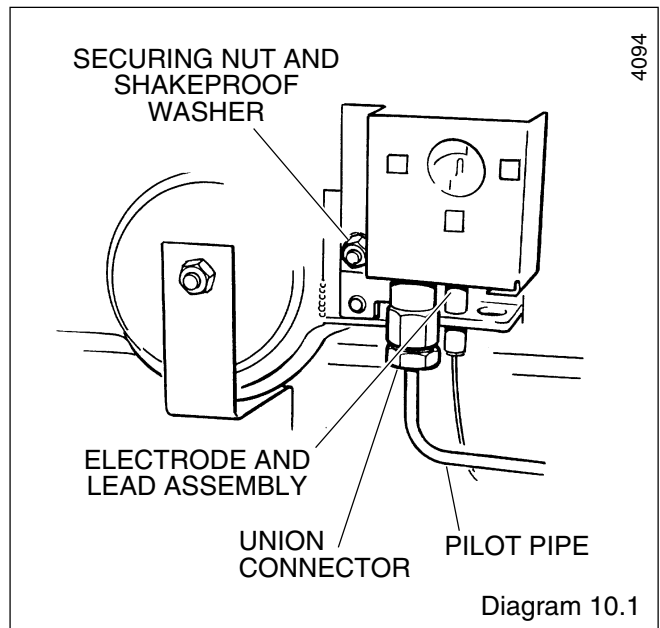

# 10 Servicing

## 10.2 Cleaning Heat Exchanger and Burner

Disconnect the air pressure tubes, see diagram 5.3.

Remove the blue and red electrical connections from the fan, see diagram 5.3.

Remove the fan taking care not to damage the gasket, see diagram 5.3.

Remove the flue hood, see diagram 5.4.

Remove the combustion chamber cover, see diagram 8.2.

Remove the cleaning plate from the combustion chamber cover, see diagram 8.2.

Disconnect the pilot pipe union connector and pilot burner, securing nut and shakeproof washer together with the pilot shield. Remove the pilot burner assembly taking care not to damage the electrode and lead assembly, see diagram 10.1.

Remove the securing screw from the burner support bracket, see diagram 10.2.

Remove the main burner from the main injector at the rear. Raise the burner up and forward, easing the pilot pipe down, to clear, take care not to damage the combustion chamber insulation or the pilot pipe.

Use a vacuum cleaner or suitable stiff brush to clean the burner thoroughly, making sure that all the burner ports are clear and unobstructed.

Place a sheet of paper in the base of the combustion chamber.

### 100 FF ONLY

Remove the baffles, see diagram 10.3.

If a vertical or flue bend systems, using corrugated bends, see Flue Kit Installations, has been fitted then the TOP FLUE BAFFLES will have been REMOVED.

Note: When replacing the bottom three baffles, the two half and one whole baffle, make sure that they are positioned with the mark "100" to front of appliance as shown in diagram 10.3.

### 120 FF ONLY

Remove the baffles, see diagram 10.4.

Note: When replacing the bottom baffle, make sure that it is positioned with the word "Bottom" to front of appliance as shown in diagram 10.4.

### Continued-

The heat exchanger can now be cleaned, paying particular attention to the gap between the fins, with a suitably sized semi-stiff brush, using the cleaning plate, as shown in diagram 10.5, to protect the rear insulation panel.

Remove the paper together with any debris.

## 10.3 Main Injector

With the main burner removed the main injector can be inspected and cleaned as necessary, see diagram 10.6.

If removing for cleaning do not use a wire or sharp instrument on the hole.

Use a little suitable sealant on the external thread when refitting to make sure a gas tight seal is made.

Note. On refitting and after cleaning the heat exchanger make sure the burner is fitted correctly, that is, located on the main injector and horizontal.

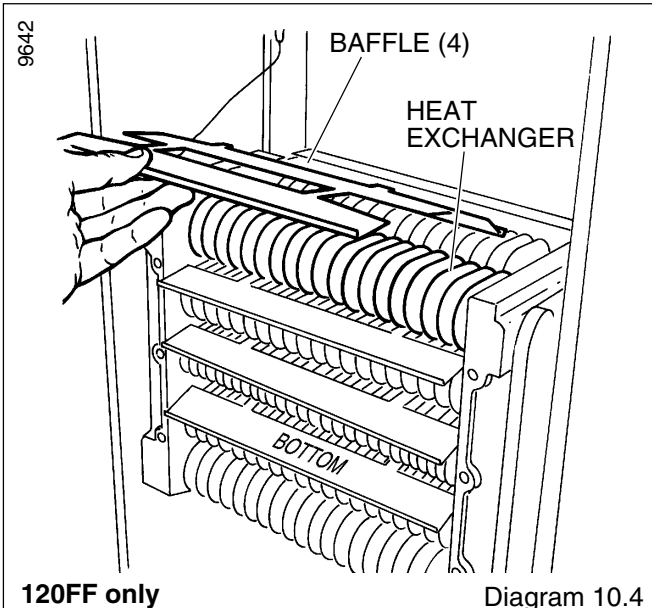
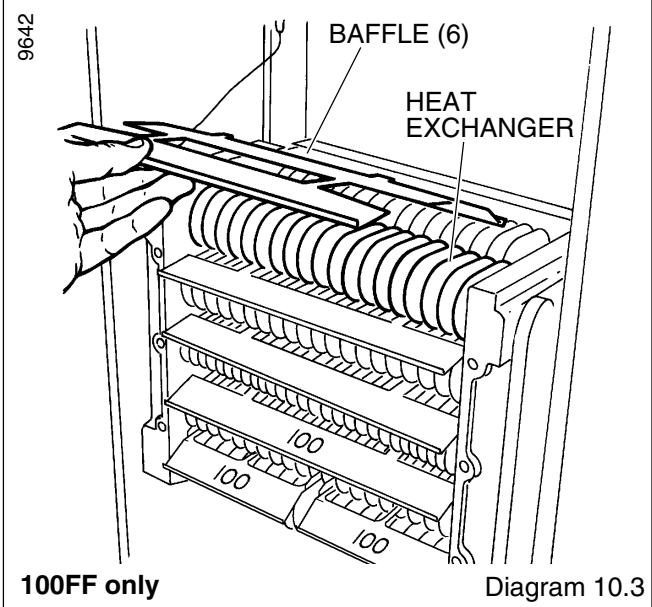
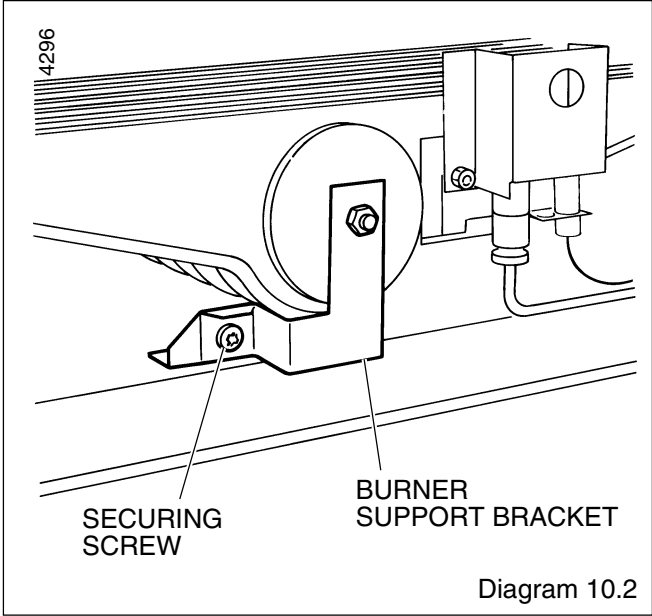

# 10 Servicing

## 10.4 Electrode, Pilot Burner and Pilot Injector

Clean the pilot burner and electrode.

100FF Model Only. To remove the electrode release the spring clip, see diagram 10.7.

120FF Model Only. To remove the electrode remove the securing screw, see diagram 10.7.

When removing and replacing the pilot injector from the pilot burner take care not to damage the electrode, see diagram 8.6, clean the injector by blowing through it.

Check that the spark gap is as shown in diagram 8.3.

## 10.5 Operational Checks

After completing a service and before fitting the case, check condition of the case seal and renew if necessary.

Examine the flue hood and terminal to make sure they are clean and clear of obstructions.

Light the boiler and carry out the functional checks as described in Section 8.

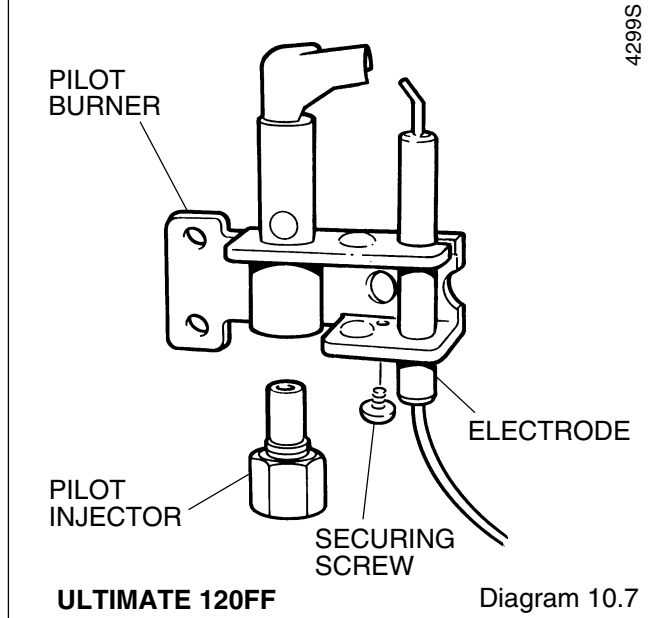
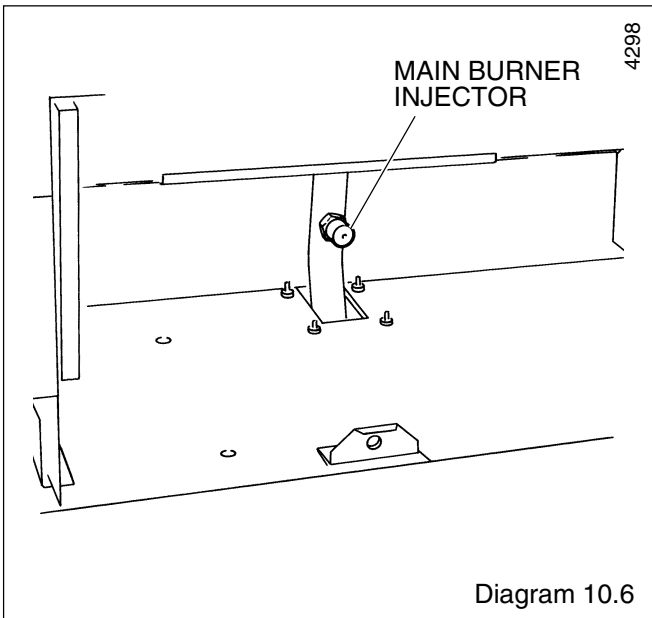
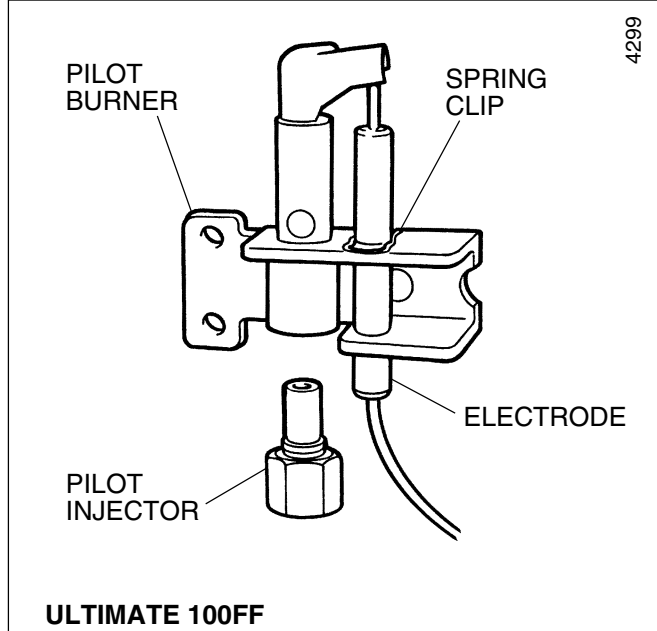
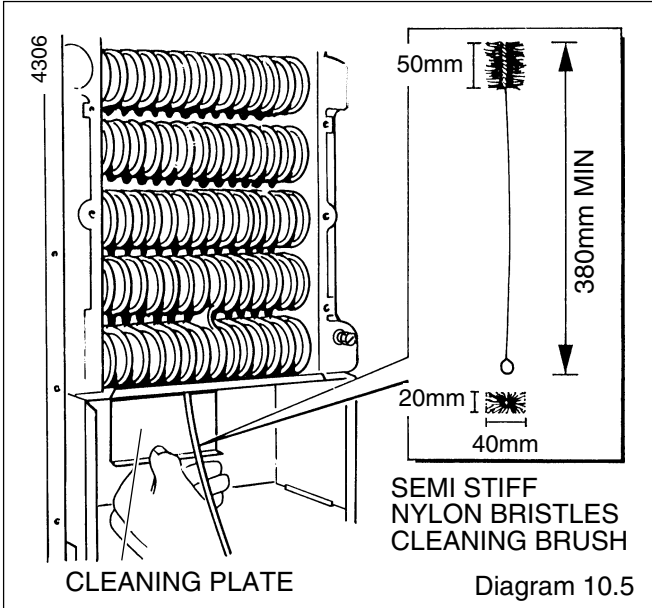

# 11 Fault Finding

## 11.1 Electrical

Important. On completion of the Service/Fault Finding task which has required the breaking and remaking of the electrical connections, the earth continuity, polarity and short circuit and resistance to earth checks must be repeated using a suitable multimeter.

Refer to diagrams 11.1 to 11.5 for the relevant fault finding and wiring information.

## 11.2 Electrical Supply Failure

Failure of the electrical supply will cause the burner to go out.

Operation will normally resume on the restoration of the electrical supply. If the burner does not relight after and electrical failure the overheat device may need resetting.

Remove the control cover, see diagram 8.6 and push the reset button on the front of the control box, see diagram 8.1.

If the cutoff operates at any other time press the reset button and the burner should relight. If the fault persists refer to the fault finding chart.

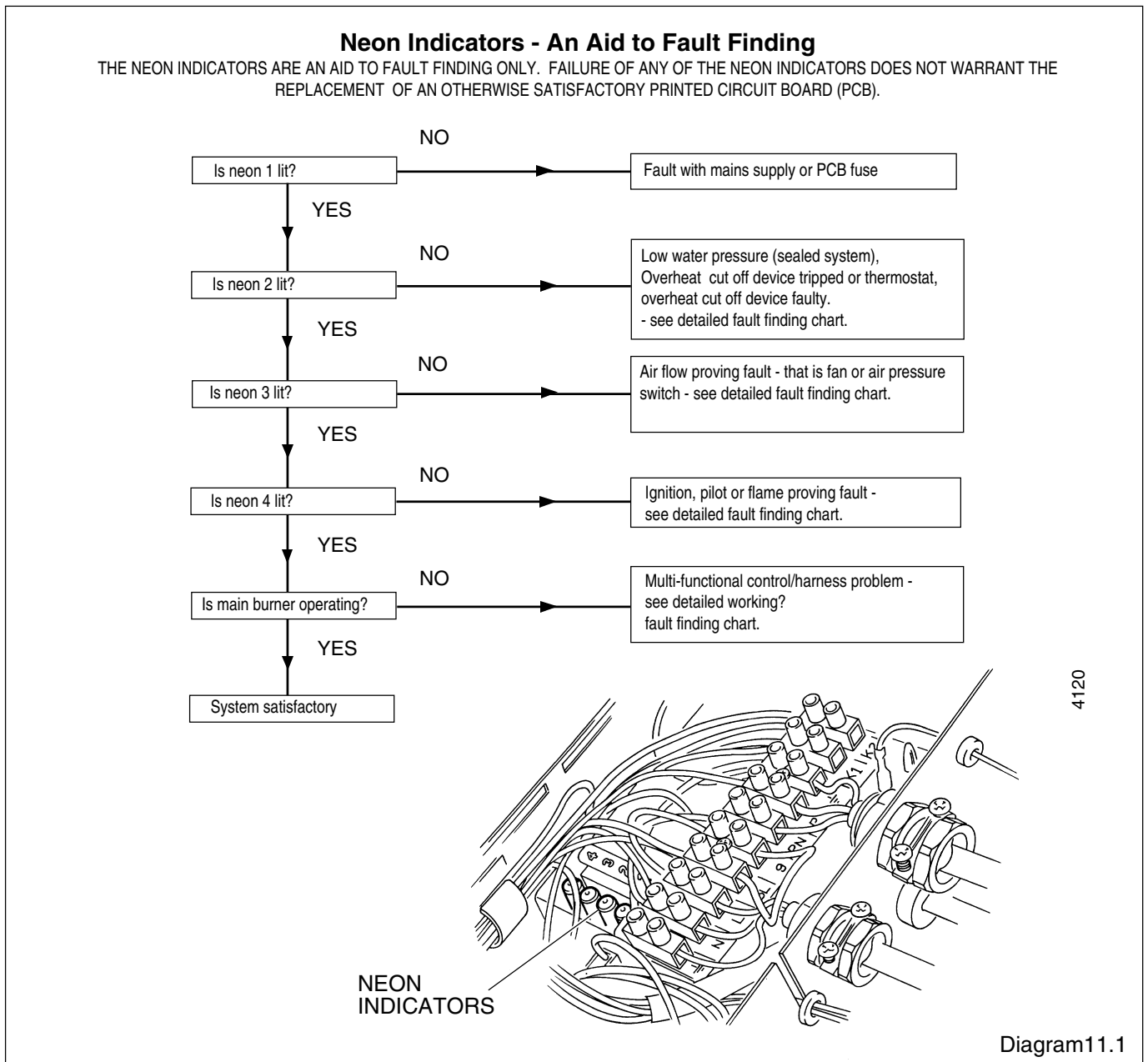

# 11 Fault Finding

Before detailed checking of electrical components ensure that remote controls are calling for heat. Check the gas supply is free of obstructions and purged of air. Check the overheat cutoff has not operated. For fully pumped systems only. Isolate the electrical supply and physically check ALL cables, connections and the printed circuit board fuse. Check the air tubes to the air pressure switch. Switch on the electrical supply and check for correct polarity. Turn the control thermostat to its maximum setting. Also check fuses.

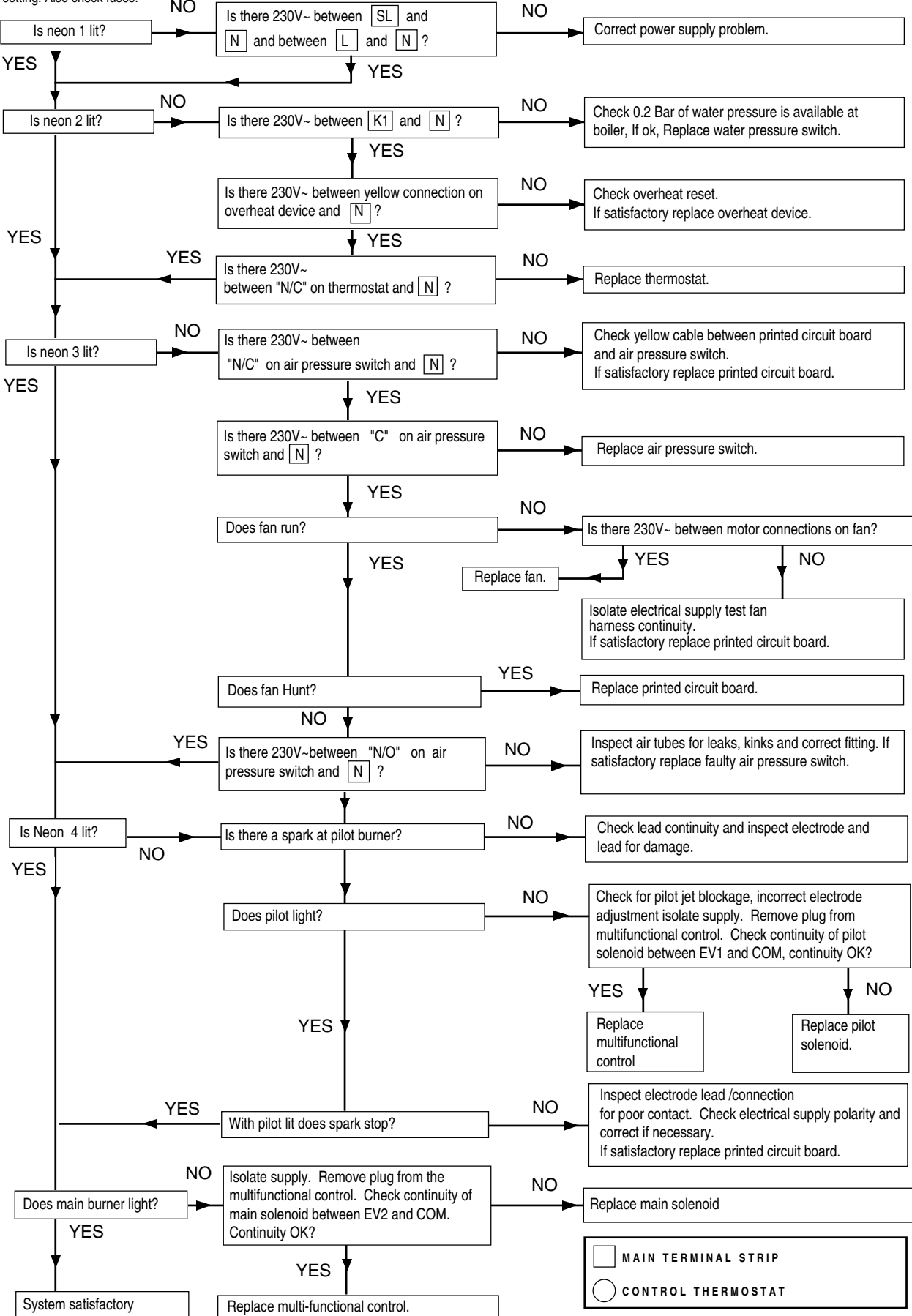
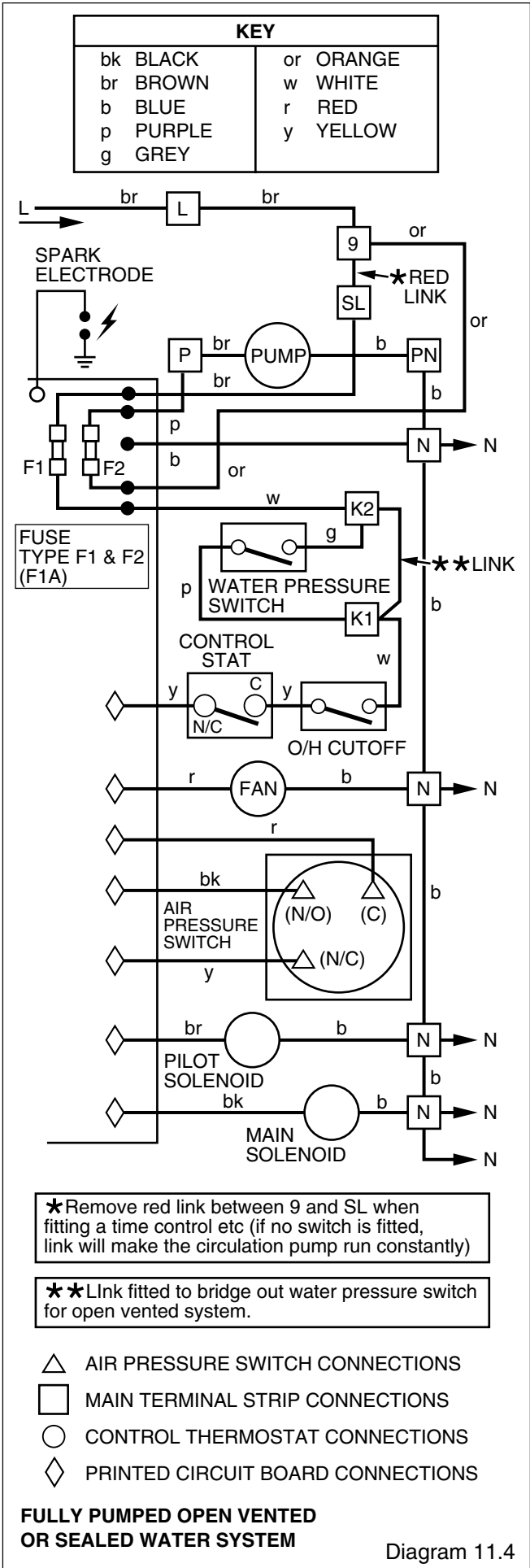
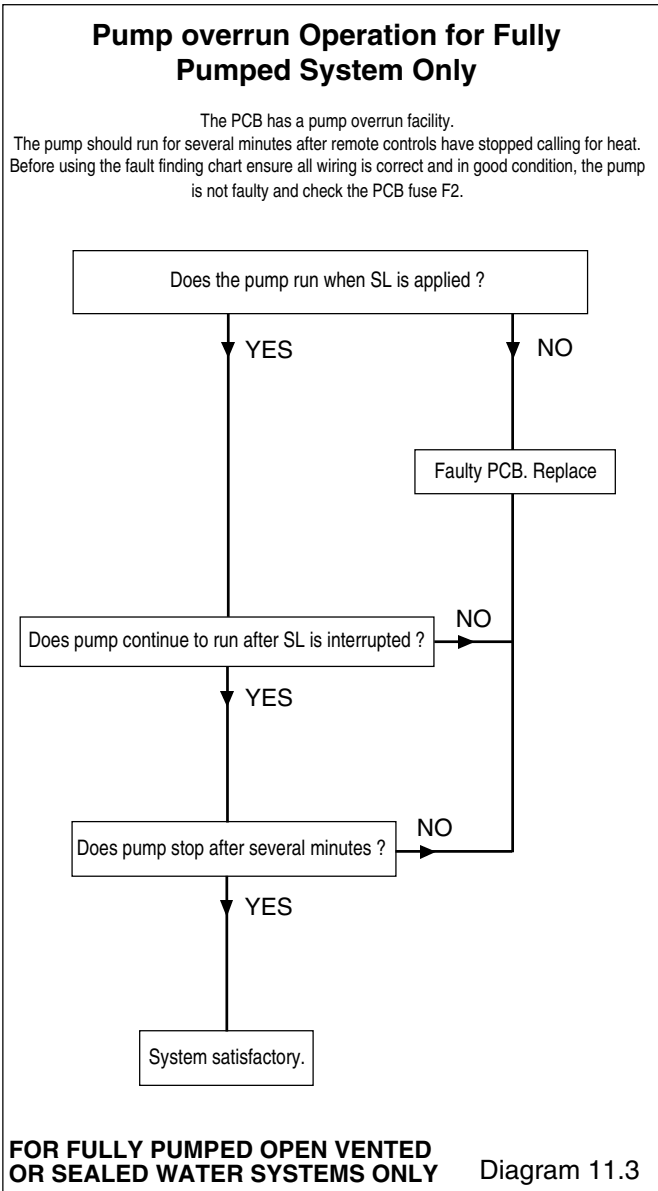

Diagram 11.2

# 11 Fault Finding



# 11 Fault Finding

9075

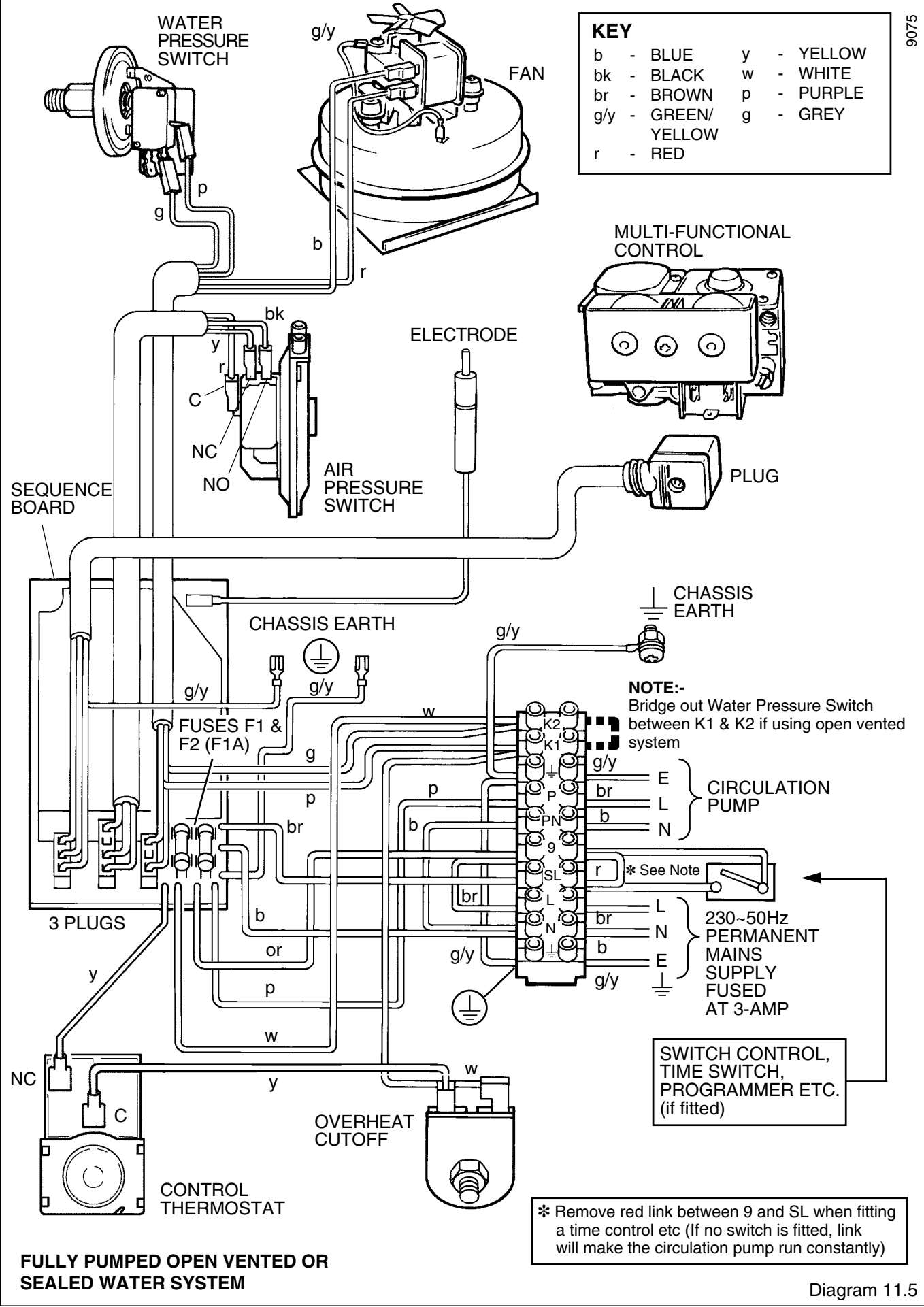

Diagram 11.5

# 12 Replacement of Parts

Note. Replacement of parts must only be carried out by a competent person.

Before replacing any parts isolate the boiler from the electrical supply and turn the gas supply off at the gas service cock, indicator slot to be vertical.

Unless stated otherwise, all parts are replaced in the reverse order to removal.

After replacing any parts always test for gas soundness and if necessary carryout functional check of controls.

### 12.1 Access

Gain access as Section 10.1.

### 12.2 Control Thermostat - diagram 12.1 and 12.2

Remove and support the electrical control box, refer to Section 7.1.

Remove the control knob. Remove the electrical connections from the control thermostat body.

Release the control thermostat body by unscrewing the two screws and shakeproof washers in the front of the control box.

Remove the split pin and withdraw the thermostat phial from its pocket. Release the capillary from the base and the plastic retaining clip then remove it from the split grommet. Release the capillary from its clips. Remove the thermostat complete from the boiler.

Reassembly note. When refitting the thermostat make sure that the thermostat phial is covered with heat sink compound then fully inserted into the phial pocket and that the capillary is within the gland seal, see diagram 12.2. Remake the electrical connections. There must be no kinks or sharp bends in the capillary.

### 12.3 Overheat Cutoff Device - diagram 12.1, 12.2 and 12.2A

Remove and support the electrical control box, refer to Section 7.1.

Remove the overheat cutoff electrical connections.

Disconnect the air pressure switch plug from the PCB.

Remove the locking nut from the overheat cutoff.

Release the capillary from the retaining clips then remove it from the split grommet.

Remove the split pin and then the phial.

When refitting use the heat sink compound supplied.

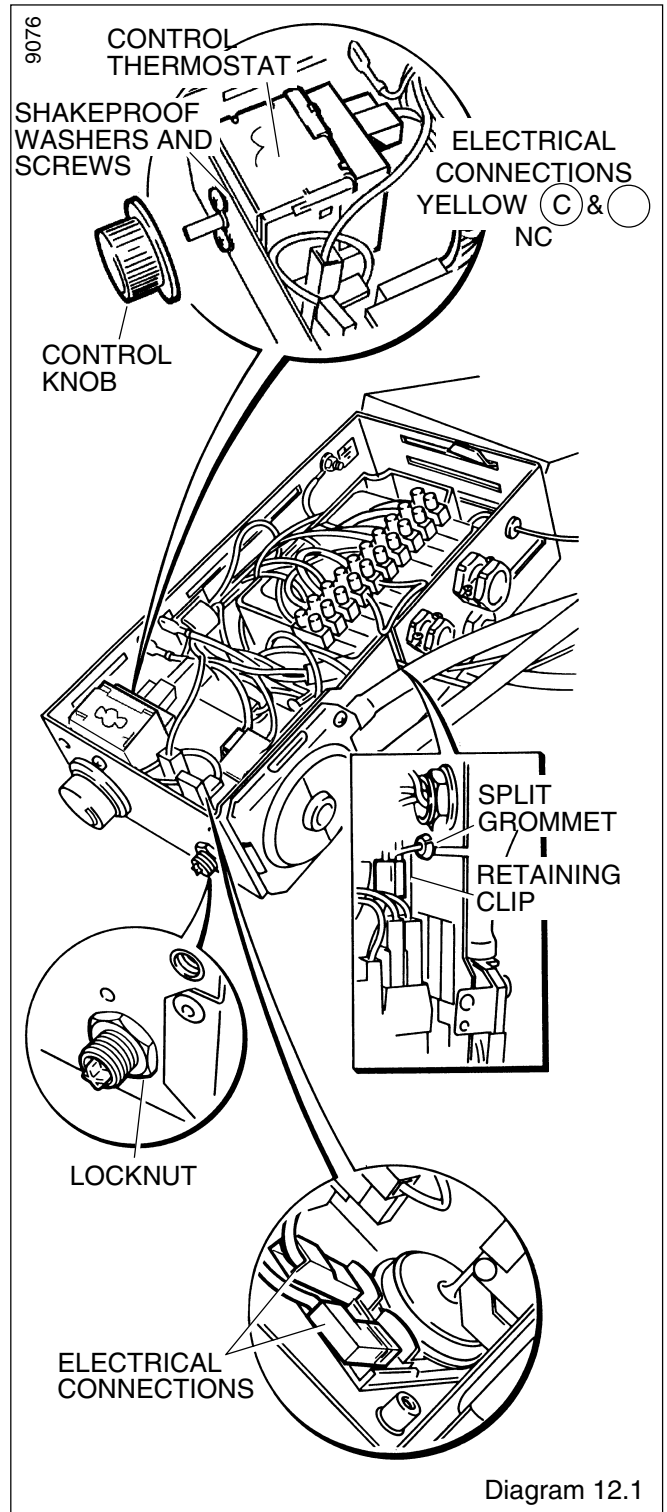

Diagram 12.1

## 12 Replacement of Parts

### 12.4 Control Board (PCB) - diagram 12.2A

Release the control box, refer to Section 7.1.  
 Disconnect the three electrical plugs and ignition lead.  
 Release the cables from the plastic retaining clip, then disconnect the cables from the PCB to the main terminal strip, control thermostat and earth connection.  
 Release the main terminal strip and plastic label.  
 Carefully pull the board away from its supports.  
 When refitting refer to wiring diagram 11.5.

### 12.5 Pilot Burner and Pilot Injector

Proceed as Section 10.2 and 10.4.

### 12.6 Electrode

Proceed as Section 8.3 and 8.5.  
 Gain access as Section 7 to remove lead from control box.

### 12.7 Multifunctional Control - diagram 10.3

Disconnect the pilot supply by unscrewing the tubing nut at the multifunctional control.  
 120FF ONLY. Take care as there is a restrictor in the pilot pipe.  
 Disconnect the electrical plug.  
 Support the multifunctional control, remove the four extended screws from the flanged connections at the left and right hand side.  
 Remove and discard the original "O" rings from the flanged connection and fit the new "O" rings supplied, into recess, before fitting the replacement multifunctional control.  
 After assembly test for gas soundness and purge in accordance with the current issue of BS6891.

### 12.8 Solenoid - diagram 12.3

Remove the electrical plugs from the multifunctional control.  
 Remove the securing screw and then the solenoid assembly.

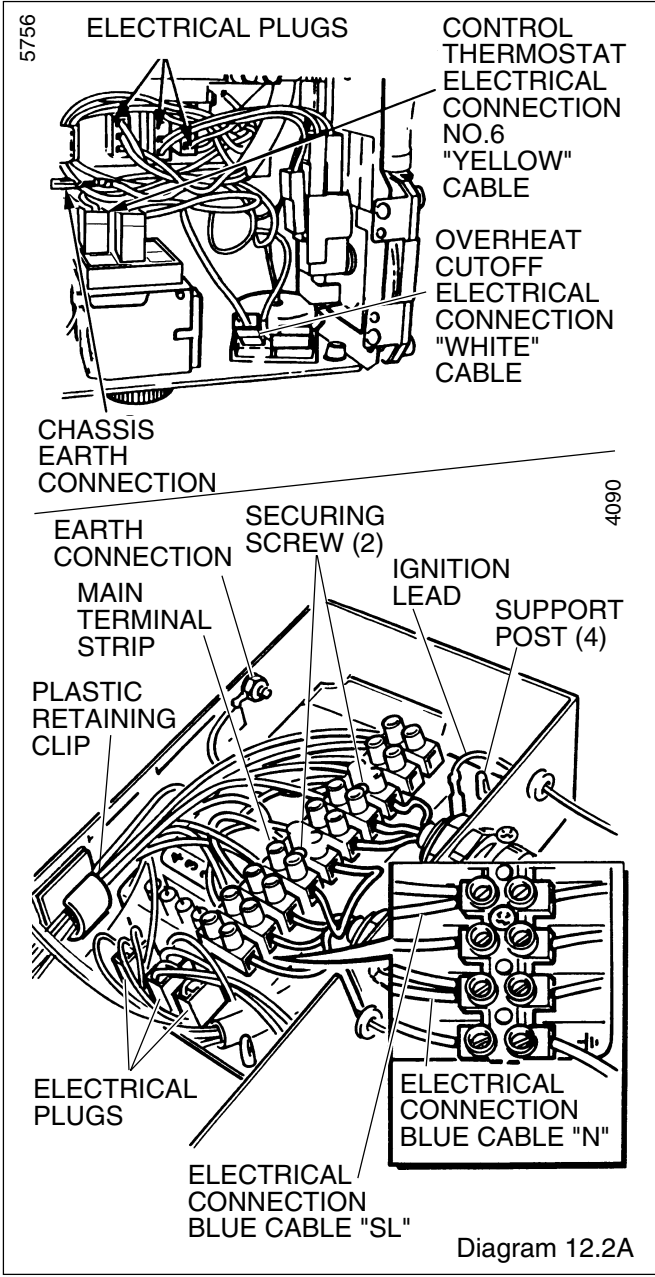
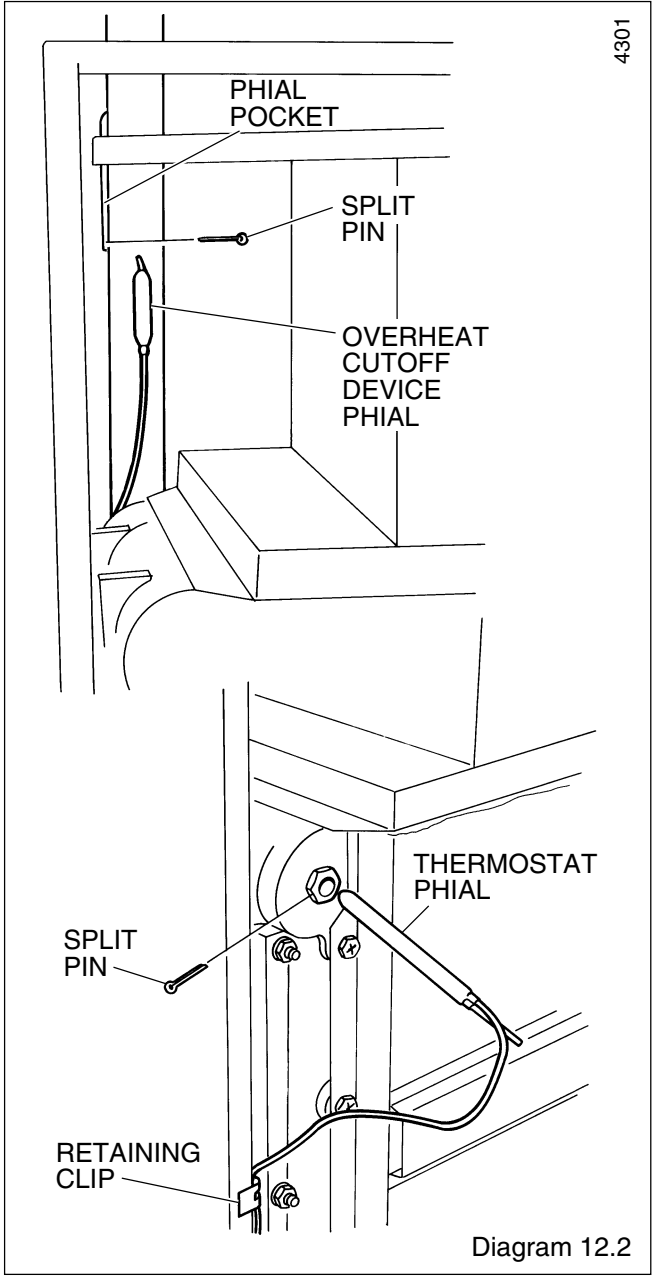

## 12 Replacement of Parts

### 12.9 Main Burner

Remove the main burner as Section 10.2.

### 12.10 Main Injector

Remove the main burner as Section 10.2.  
Remove the main injector as Section 10.3.

### 12.11 Insulation - diagram 12.4

#### Combustion Chamber Front

Remove the retaining screw then the insulation.

#### Sides

Slide the insulation out.

### 12.12 Viewing Window - diagram 12.5

Remove the old self adhesive aluminium foil gasket and the old mica window. Replace with a new mica window. Peel off the backing paper and secure with new self adhesive aluminium foil gasket, see diagram 12.5. Ensure no air bubbles are trapped underneath the foil.

### 12.13 Air Pressure Switch - diagram 12.6

Release the control box as Section 7.1

Remove the pressure tubes and the electrical connections from the PCB, release the screws and remove the switch.

When fitting the replacement make sure that the plastic tubes and electrical connections are made as shown in diagram 11.5 and 12.6.

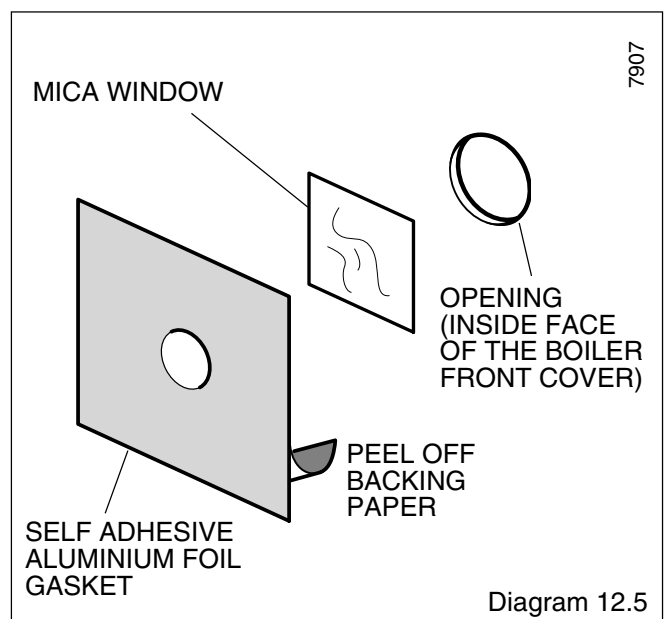
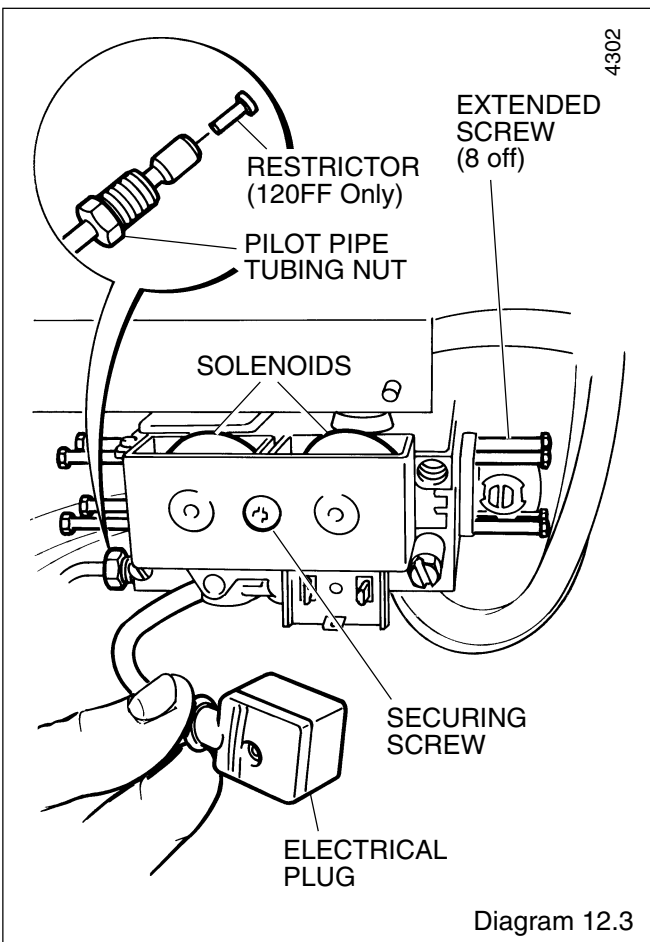
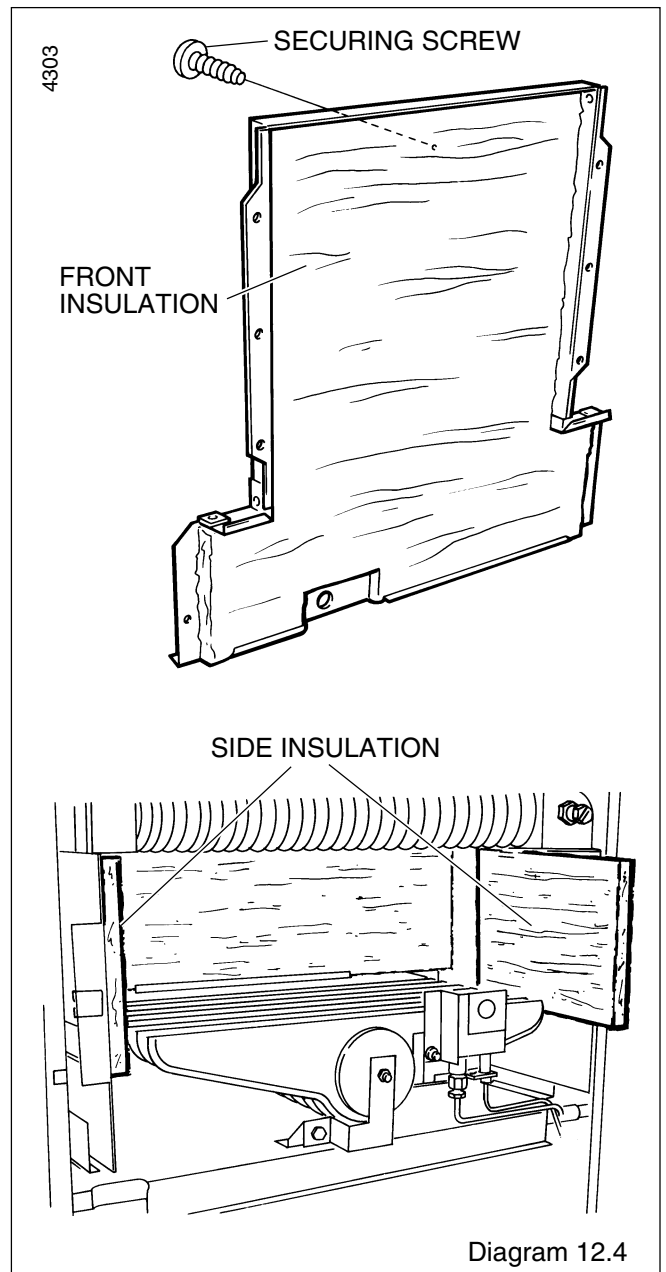

# 12 Replacement of Parts

## 12.14 Fan - diagram 5.3

Remove the electrical connections and disconnect the air pressure tubes.

Remove the fan assembly securing screws.

Make sure that the earth connection is remade onto the new fan assembly.

The polarity of the other connections is not important.

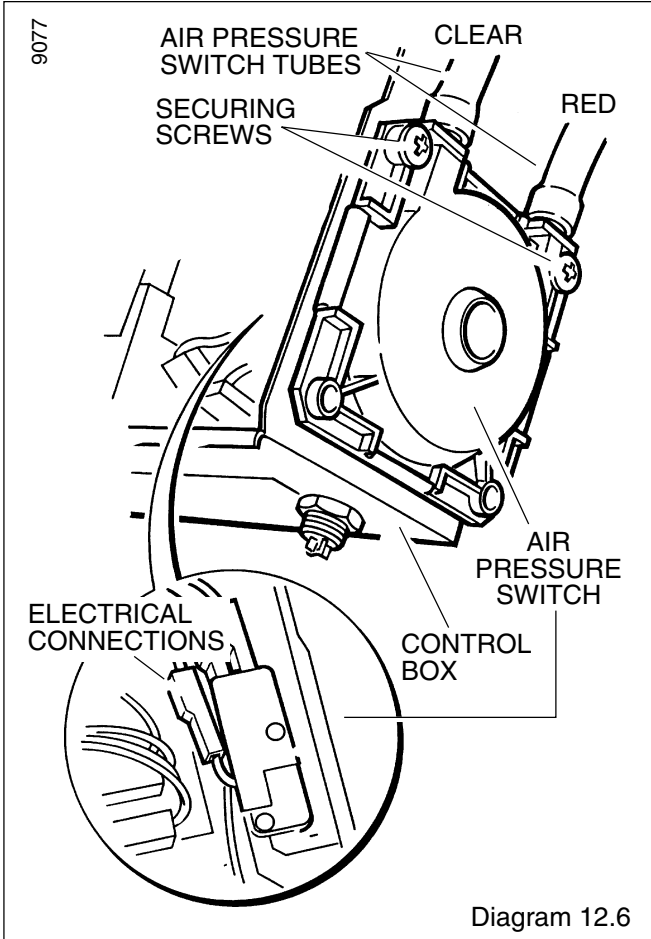

## 12.15 Water Pressure Switch - Sealed Water System Only

Release the water pressure and drain, refer to Section 3.

Disconnect the electrical connections at the microswitch, see diagram 12.7.

Remove pressure switch.

On assembly, use new "O" ring, secure the water pressure switch with locknut in the orientation shown as diagram 12.7.

Make up water loss and pressurise system, refer to "Commissioning".

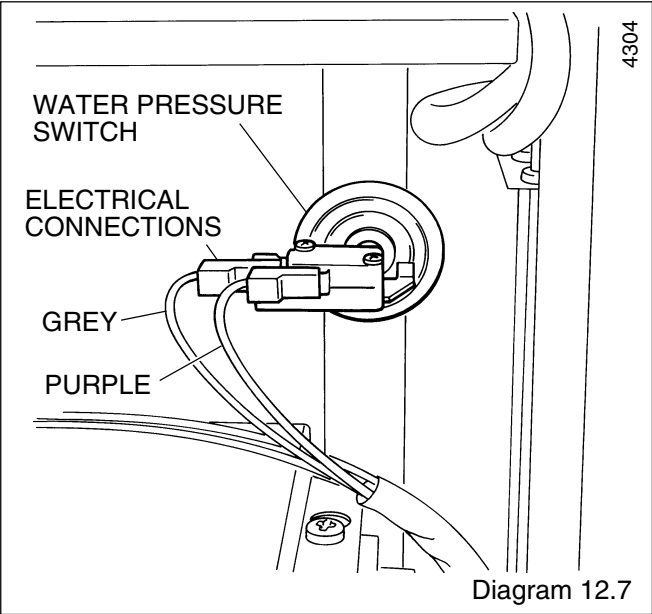

# 13 Spare Parts

## 13.1 Part Identification

The key number in the diagram and the first column of the list will help to identify the spare part.

## 13.2 Ordering

When ordering any spare part, please quote the part number and the description from the list together with the model name and serial number information from the data label. The data label is positioned at the bottom right hand side of case.

If ordering from British Gas also quote the GC number of the appliance from the data label and the GC number of the spare part, from the list.

## 13 Spare Parts

Key No	Part No	Description	GC Part No
1	800442	Multifunctional control	278 021
2	208040	"O" ring	334 592
3	205727	Injector - 100FF	278 197
3	205726	Injector - 120FF	278 196
4	203432	Pilot burner - 100FF	278 023
4	203434	Pilot burner - 120FF	E00 998
5	801236	Mica Glass	*****
6	800529	Fan assembly - 100FF	278 194
6	800532	Fan assembly - 120FF	278 185
7	202626	Spark electrode and lead - 100FF	313 998
7	202629	Spark electrode and lead - 120FF	278 238
8	K3580	Clip - electrode	390 983
9	800850	Thermostat - control	*****
10	202232	Air pressure switch - 100FF	278 239
10	202201	Air pressure switch - 120FF	313 992
11	800275	Control knob	313 609
12	800656	Water pressure switch	*****
13	204212	"O" ring	281 343
14	202015	Fuse	334 750
15	900847	Control board PCB	*****
16	800272	Overheat safety cutoff	313 606

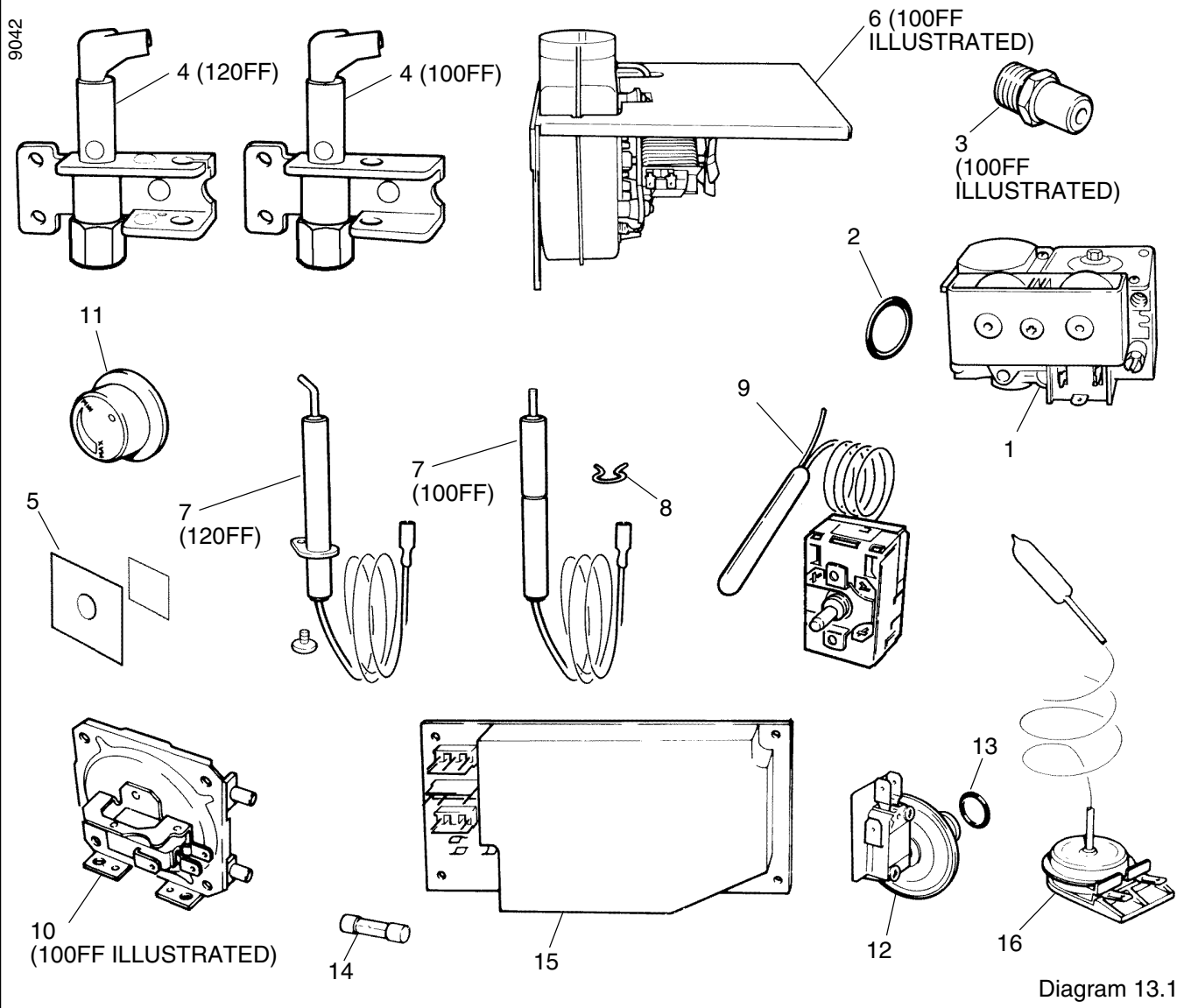

*Because of our constant endeavour for improvement, details may vary slightly from those shown in these instructions.*