



2000225229

Instructions for Use Installation and Servicing

To be left with the user

Micron 70FF

G.C. No. 41-047-50

Fanned Flue Boiler



The code of practice for the installation, commissioning & servicing of gas central heating

This is a Cat I_{2H} Appliance

Reference in these instructions to British Standards and Statutory Regulations/Requirements apply only to the United Kingdom.

For Ireland the current edition of I.S.813 "Domestic Gas Installations" must be used.

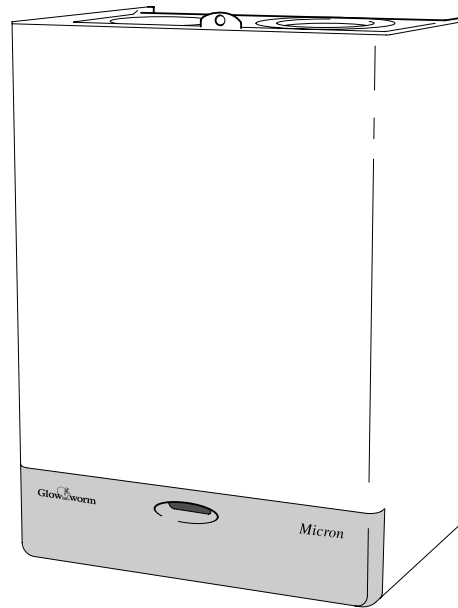

THIS DOCUMENT HAS BEEN PROVIDED BY
heatingspares247.com
PLEASE VISIT WWW.HEATINGSPPARES247.COM FOR FURTHER INFORMATION AND GENUINE PARTS & SPARES AT LOW PRICES

The instructions consist of three parts, User, Installation and Servicing Instructions, which includes the Guarantee Registration Card. The instructions are an integral part of the appliance and must, to comply with the current issue of the Gas Safety (Installation and Use) Regulations, be handed to the user on completion of the installation.

Guarantee Registration

Thank you for installing a new Glow-worm appliance in your home.

Glow-worm appliances' are manufactured to the very highest standard so we are pleased to offer our customers' a Comprehensive First Year Guarantee.

In the centre pages are to be found your Guarantee Registration Card, which we recommend you complete and return as soon as possible.

If this card is missing you can obtain a copy or record your registration by telephoning the Heatcall Customer Service number 01773 828100.

Our Guarantee gives you peace of mind plus valuable protection against breakdown by covering the cost of:

- All replacement parts**
- All labour charges**
- All call-out charges**

**REGISTER YOUR GLOW-WORM APPLIANCE
FOR 1ST YEAR GUARANTEE PROTECTION**

CALL 0208 247 9857

HEATCALL

Customer Services:

Tel: (01773) 828100

One Contact Local Service

Fax: (01773) 828070

Hepworth Heating Ltd.,
Nottingham Road, Belper, Derbyshire. DE56 1JT

General/Sales enquiries:

Tel: (01773) 824141 Fax: (01773) 820569

Important Information

Testing and Certification

This boiler is tested and certificated to EN483 for safety and performance. It is therefore important that no alteration is made to the boiler, without permission, in writing, from Hepworth Heating Ltd.

Any alteration not approved by Hepworth Heating Ltd., could invalidate the certification, boiler warranty and may also infringe the current issue of the Statutory Requirements.

CE Mark

This boiler meets the requirements of Statutory Instrument No. 3083 The boiler (Efficiency) Regulations, and therefore is deemed to meet the requirements of Directive 92/42/EEC on the efficiency requirements for new hot water boilers fired with liquid or gaseous fuels.

Type test for purposes of Regulation 5 certified by: Notified body 0086.

Product/productioncertifiedby: Notified body 0086.

The CE mark on this appliance shows compliance with:

1. Directive 90/396/EEC on the approximation of the Laws of the Member States relating to appliances burning gaseous fuels.
2. Directive 73/23/EEC on the harmonization of the Laws of the Member States relating to the electrical equipment designed for use within certain voltage limits.
3. Directive 89/336/EEC on the approximation of the Laws of the Member States relating to electromagnetic compatibility.

INFORMATION FOR THE INSTALLER AND SERVICE ENGINEER.

Under Section 6 of The Health and Safety at Work Act 1974, we are required to provide information on substances hazardous to health.

Insulation pads and Glass yarn.

These can cause irritation to skin, eyes and the respiratory tract. If you have a history of skin complaint you may be susceptible to irritation. High dust levels are usual only if the material is broken. Normal handling should not cause discomfort, but follow normal good hygiene and wash your hands before eating, drinking or going to the lavatory. If you do suffer irritation of the eyes or severe irritation to the skin seek medical attention.

SPARE PARTS

REMEMBER, When replacing a part on this appliance, use only spare parts that you can be assured conform to the safety and performance specification that we require. Do not use reconditioned or copy parts that have not been clearly authorised by Hepworth Heating Ltd.

CONTENTS	DESCRIPTION	SECTION	PAGE No.
INSTRUCTIONS FOR USE	Introduction		3
	Lighting the Boiler		3
INSTALLATION INSTRUCTIONS	General Data	1	4
	Flue and Ventilation	2	7
	Water Systems	3	8
	Flue and Appliance Preparation	4	10
	Boiler Installation	5	13
	Commissioning	6	17
	Instructions to the User	7	19
SERVICING INSTRUCTIONS	Servicing	8	20
	Fault Finding	9	21
	Replacement of Parts	10	25
	Spare Parts	11	28

Instructions for Use

Introduction

Please read these instructions and follow them carefully for the safe and economical use of your boiler.

The Micron series are fanned flue boilers designed to provide central heating and indirect domestic hot water.

The boiler is fully automatic in operation having only one user control, the temperature control.

WARNING. It is important that the case is not disturbed or removed other than for servicing by a competent person.

Gas Leak or Fault

If a gas leak or fault exists or is suspected, the boiler must be turned off, including the electrical supply and must not be used until the fault has been put right.

Advice/help should be obtained from your installation/servicing company or the local gas undertaking.

Electrical Supply Failure

Failure of the electrical supply will cause the burner to go out. Should this occur, operation of the appliance will normally resume after the electrical supply is restored.

If the boiler does not relight after an electrical supply failure the overheat safety cutoff device may need resetting, as indicated by illuminated reset light. Open the controls cover and turn temperature control to "0" (anticlockwise) and then back to original position, refer to diagram 9.1.

Note: If the boiler is switched OFF, manually, wait at least 30 seconds before switching on again.

Safety Temperature Limiter

If the safety Temperature Limiter operates on any other occasion than an electrical supply failure, follow the procedure as in "Electrical Supply Failure". If the overheat operates again, turn the appliance off and contact your installation/servicing company.

Protection Against Freezing.

In this boiler there is a built-in frost protection, which will cause the boiler, when it is switched off at the control knob, to operate in the event of the water temperature in the boiler dropping to 6°C or 7°C. The boiler will switch off again when the temperature of the water in the boiler reaches about 15°C.

Note: The frost protection will not operate if the electrical supply is turned off.

If the boiler is to be out of use for any long period of time during severe weather conditions we recommend that the whole of the system, including the boiler, be drained off to avoid the risk of freezing up. Make sure that, if fitted, the immersion heater in the cylinder is switched off.

Maintenance

To ensure the continued efficient and safe operation of the boiler it is recommended that it is checked and serviced as necessary at regular intervals. The frequency of servicing will depend upon the particular installation conditions and usage, but in general once a year should be enough.

If this appliance is installed in a rented property in the UK there is a duty of care imposed on the owner of the property by the current issue of The Gas Safety (Installation and Use) Regulations, Section 35.

It is the law that any servicing is carried out by a competent person.

To obtain service, please call your installer or Heatcall (Glow-worm's own Service Organisation) using the telephone number given on the front cover of these instructions.

Please be advised that the 'Benchmark' logbook should be completed by the installation engineer on completion of commissioning and servicing.

All CORGI Registered Installers carry a CORGI ID card, and have a registration number. Both should be recorded in your boiler Logbook. You can check your installer is CORGI registered by calling CORGI direct on :- 01256 372300.

Cleaning

WARNING. This appliance contains metal parts (components) and care should be taken when handling and cleaning, with particular regard to edges.

Clean the casing occasionally by wiping it over with a damp cloth or dry polishing duster.

Do not use an abrasive cleaner.

To Light the Boiler

WARNING. Sealed Systems

A sealed water system must be filled and pressurised by a competent person.

Only light the boiler when you are sure that the system has been filled and pressurised.

The pressure gauge should show at least 0.7bar, anything less than this figure could indicate a leak and you **MUST** contact your installation/servicing company.

If there is any doubt about the boiler being full of water consult your installation/servicing company.

ALL SYSTEMS.

Turn the electrical supply on to the boiler and check that all remote controls are calling for heat. Check also that the programmer (if fitted) is in the "ON" mode.

To Turn the Boiler On

Open the controls cover, see diagram 9.1.

Turn the control knob clockwise to any position between "O" and MAX. The maximum temperature setting is approx. 82°C (180°F), see diagram 9.1.

The boiler lighting operation is now automatic as follows:

The fan will operate for 10 seconds prior to the start of the ignition sparks, the gas valve solenoids will open and the burner will light. This is shown by the "Burner Lit" LED on the control panel lighting up.

The burner will remain alight until switched off by the control thermostat, any remote control or the programmer.

Note: If the boiler is switched OFF, by hand, wait at least 30 seconds before switching on again.

When the boiler switches off, the boiler will go out.

The automatic lighting sequence will operate again when heat is required.

Shut the controls cover.

It should be noted that this is a fan flue appliance and fan operation may be heard.

To Turn the Boiler Off

For short periods, turn the control knob anti-clockwise to "0" Off. To relight, turn the control knob to any position between "O" and "MAX".

For longer periods, turn the control knob fully anti-clockwise to "0" Off and switch off the electrical supply to the boiler.

To relight follow the lighting sequence given above.

Programmer

An optional programmer is available, which will automatically switch your central heating system on and off once or twice a day at whatever times you choose.

Note: If the programmer is manually switched on then off when the boiler is cold, the boiler may continue to operate for about 30 seconds before switching off.

Installation - 1 General

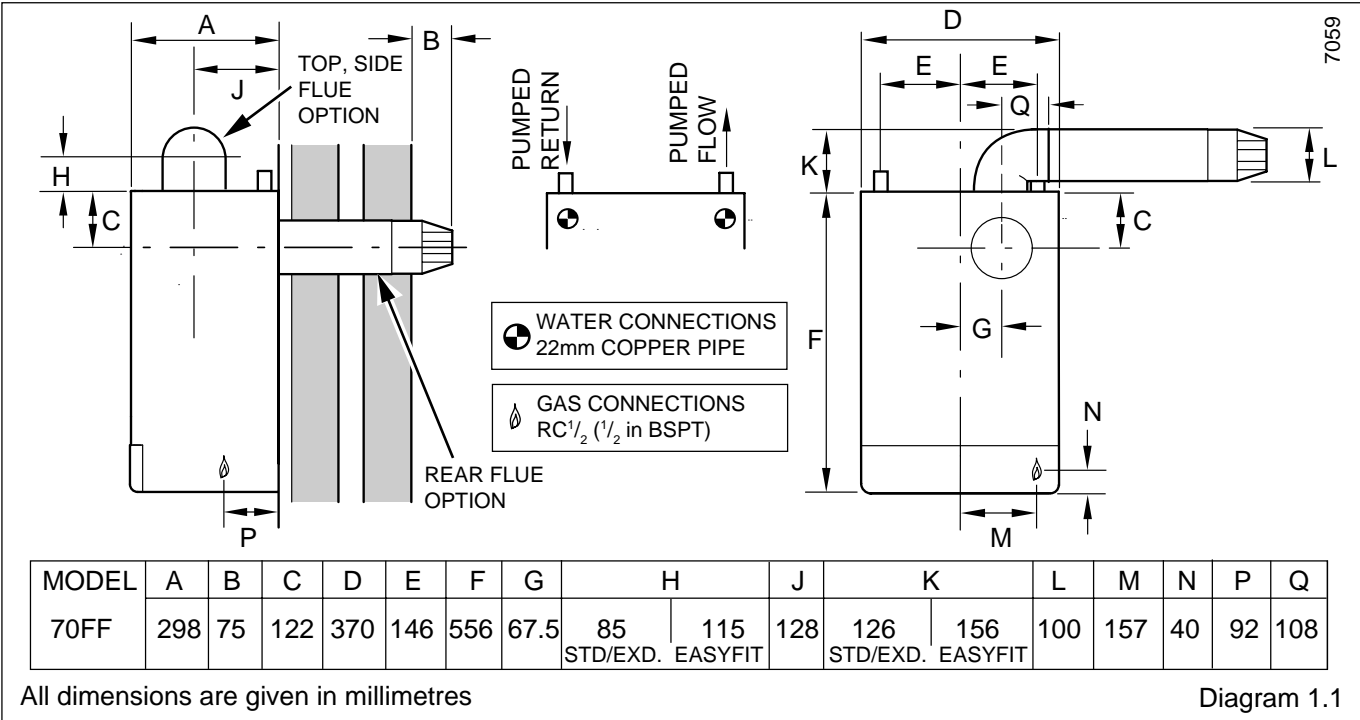

All dimensions are given in millimetres

Diagram 1.1

Important Notice

This boiler is for use on natural gas (G20) as distributed in the United Kingdom and Ireland and cannot be used on any other gas.

This boiler can be used on open vented or sealed water systems.

Domestic hot water must be provided by pumped circulation.

Wherever possible, all materials, appliances and components used shall comply with the requirements of applicable British Standards.

Where no British Standards exists, materials and equipment should be fit for their purpose and of suitable quality and workmanship.

Sheet Metal Parts

WARNING. When installing or servicing this boiler care should be taken when handling sheet metal parts, to avoid any possibility of personal injury.

1.1 Statutory Requirements

The appliance is suitable only for installation in GB and IE and should be installed in accordance with the rules in force.

In GB the installation of the boiler must be carried out by a competent person as described in the following regulations:

- The manufacturer's instructions supplied.
- The Gas Safety (Installation and Use) Regulations.
- The appropriate Buildings Regulations either The Building Regulations, The Building Regulations (Scotland), The Building Regulations (Northern Ireland).
- The Water Fittings Regulations or Water byelaws in Scotland.
- The Health and Safety at Work Act, Control of Substances Hazardous to Health (COSHH).
- The Current I.E.E. Wiring Regulations.

Where no specific instructions are given, reference should be made to the relevant British Standard Code of Practice.

In IE, the installation must be carried out by a competent person and installed in accordance with the current edition of I.S.813

"Domestic Gas Installations", the current Building Regulations and reference should be made to the current ETCl rules for Electrical Installation.

In GB the following Codes of Practice apply:

- BS4814, BS6798, BS5440 Part 1 and 2, BS5546 Part 1, BS5449, BS6891, BS6700, BS7074 Part 1 and 2, BS7593, BS7671.

In IE: I.S.813, BS5546, BS 5449, BS 7074, BS 7593.

Manufacturer's instructions must not be taken as overriding statutory requirements.

1.2 Data

See diagrams 1.1, 1.2 and Table 1.

All dimensions are given in millimetres

The Seasonal Efficiency Domestic Boilers UK (SEDBUK) is 78.2%.

The value is used in the UK Government's Standard Assessment Procedure (SAP) for energy rating of dwellings. The test data from which it has been calculated have been certified by B.S.I.

1.3 Range Rating

This boiler is range rated and may be adjusted to suit individual system requirements, refer to diagram 1.2 for data label position, ratings and settings.

1.4 Heating System Controls

The heating system should have installed: a programmer and room thermostat controlling the boiler.

Thermostatic radiator valves may be installed, however they must not be fitted in a room where the room thermostat is located.

Note: For further information, see the current issue of the Building Regulations, approved document L1 (in the UK) and the references:

- 1) GIL 59, 2000: Central heating system specification (CheSS) and
- 2) GPG 302, 2001: Controls for domestic central heating system and hot water. BRECSU.

An optional programmer for fitting on the boiler is available, kit no. 458065.

1 General

1.5 Gas Supply

The gas installation shall be in accordance with the relevant standards.

In GB this is BS6891.

In IE this is the current edition of I.S.813 "Domestic Gas Installations".

The supply from the governed meter must be of adequate size to provide a steady inlet working pressure of 20mbar (8in wg) at the boiler.

On completion test the gas installation for soundness using the pressure drop method, purge in accordance with the above standard.

1.6 Electrical Supply

WARNING. This boiler must be earthed.

All system components shall be of an approved type and shall be connected in accordance with the current issue of BS7671 and any applicable local regulations.

External wiring must be correctly earthed, polarised and in accordance with the relevant standards.

In GB this is BS6891.

In IE this is the current edition of I.S.813 "Domestic Gas Installations".

Connection of the boiler and system controls to the mains supply must be through a common isolator and must be fused 3A, maximum. This method of connection must be by a fused double pole isolating switch, with a minimum contact separation of 3mm on both poles. The switch should be readily accessible and preferably adjacent to the appliance. It should supply the appliance only and be easily identifiable as so doing.

Alternatively, an unswitched shuttered socket outlet and 3A fused 3 pin plug, both to the current issue of BS1363 may be used provided that they are not used in a room containing a bath or shower.

Wiring to the boiler must be PVC 85°C insulated cable, not less than 0.75mm² (24/0.20mm).

1.7 Contents of Packaging

The boiler is delivered in two or more packs, depending on flue system, refer to diagram 4.1 for contents.

1.8 Water System

This boiler may be fitted to an open vented or a sealed water system.

1.9 Draining Tap

System

A draining tap must be provided at the lowest points of the system which will allow the entire system and hot water cylinder to be drained.

Draining taps should be to the current issue of BS2879.

Boiler

A draining point is fitted at the bottom right hand side of the heat exchanger.

When draining is required, cover the controls to avoid water damage.

If required remove the combustion chamber front cover to improve access.

1.10 Safety Valve

A safety valve need not be fitted to an open vented system.



HEPWORTH HEATING LTD.,
BELPER, DERBYS. DE56 1JT

9444

MICRON 70FF 458679

230V~ 50Hz 81W Fused at 3A TYPE : C₁₂- C₃₂
 For use on G20 gas only NO_x Class 2 | PMS=3.0 bar
 Supply pressure 20 mbar GC No. 41-047-50
 This boiler is intended exclusively
 to be installed on a gas supply
 with a governed meter. **CE0086 GBIE**

INJECTOR: 1.07mm 205764 86/AT/565

RANGE RATING		MIN	MID	MAX	
HEAT INPUT	kW	19.86	21.40	22.65	
NETT Q =	Btu/h	67750	73030	77290	
HEAT OUTPUT	kW	17.58	19.05	20.51	Cat. I _{2H}
P =	Btu/h	60000	65000	70000	
HOT BURNER	mbar	10.4	12.0	13.6	EN437
PRESSURE	in wg	4.2	4.8	5.5	

Position against setting

SERIAL No.

PMS = 3.0 bar, is: Maximum water-side operating pressure.

The appliance flue type is a C₁₂ and C₃₂. This refers to a concentric flue where the fan is downstream of the heat exchanger. The C₁₂ is a horizontal flue termination and the C₃₂ is a vertical flue termination.



7316

Diagram 1.2

TABLE 1.	
TOTAL DRY WEIGHT (Including Terminal)	49.2 kg
LIFT WEIGHT	40.3 kg
WATER CONTENT	3.35 litre (0.74 gallon)
GAS CONNECTION	Rc 1/2 in.
ELECTRICITY RATING	81W Internal fuse Type T3.15A
WATER CONNECTION	2x22mm copper pipes from back of case
ELECTRICITY SUPPLY	230V~50Hz, fused 3A
DATA LABEL	Top left of inside of case

1 General

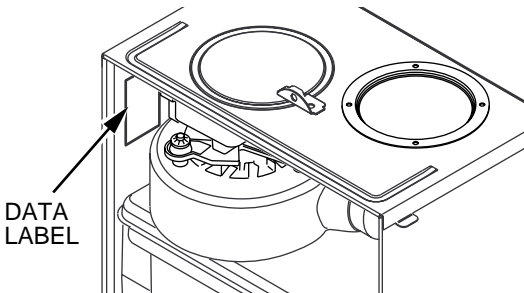
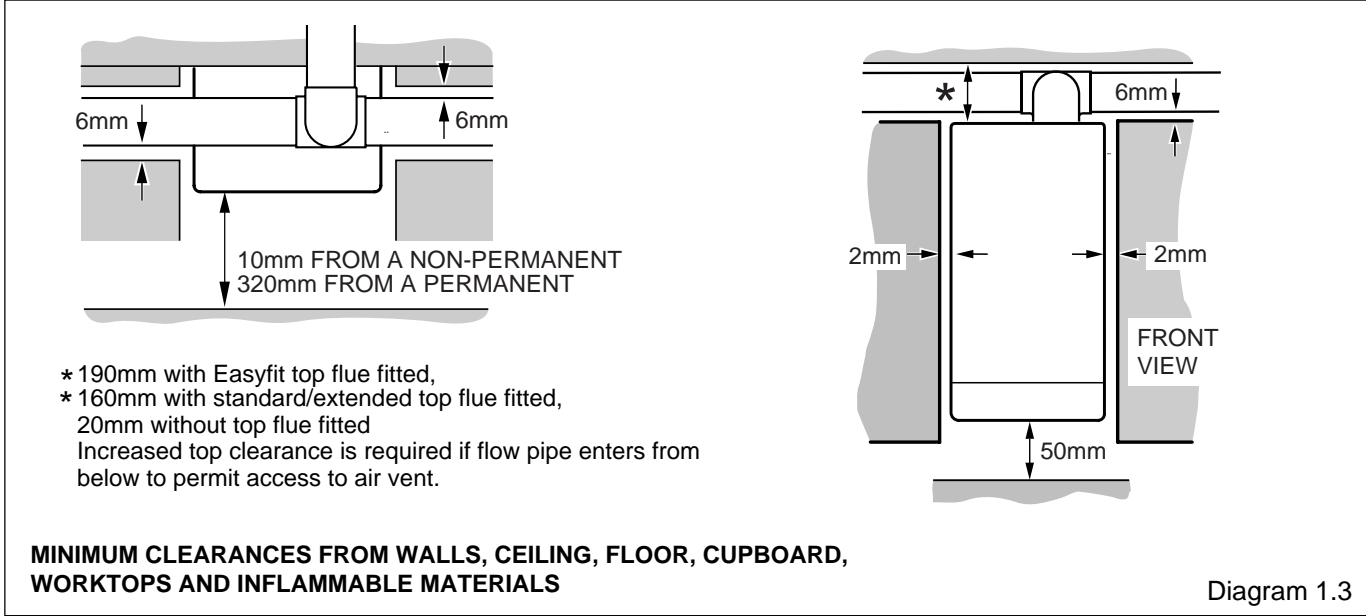

1.11 Location

This boiler is not suitable for outdoor installation.

This boiler may be installed in any room, although particular attention is drawn to the installation of a boiler in a room containing a bath or shower where reference must be made to the relevant requirements.

In GB this is the current I.E.E. WIRING REGULATIONS and BUILDING REGULATIONS.

In IE reference should be made to the current edition of I.S.813 "Domestic Gas Installations" and the current ETCI rules.

Any electrical switch or boiler control utilising mains electricity should be placed so that it cannot be touched by a person using the bath or shower. The electrical provisions of the Building Standards (Scotland) apply to such installations in Scotland.

The boiler must be mounted on a flat wall which is sufficiently robust to take its total weight.

The boiler may be fitted to a wall made of combustible material.

1.12 Boiler Clearances

Refer to diagram 1.3.

This boiler must be positioned so that at least the minimum operational and servicing clearances are provided.

Additional clearances may be required for installation.

If fixtures are positioned next to the boiler ensure access is provided for pipework installation.

At least a minimum clearance of 320mm from a permanently fixed surface must be left in front of the boiler for servicing, see diagram 1.3.

1.13 Room Ventilation

The boiler is room sealed and does not require the room or space containing it to have permanent air vents.

1.14 Boilers in a Compartment

Where the installation of the boiler will be in an unusual position, the current issue of BS6798 gives detailed guidance on these requirements.

An existing cupboard or compartment modified for the purpose may be used, providing minimum clearances are maintained. Details of essential requirements for cupboard or compartment design are given in the current issue of BS6798.

The doorway opening should be of sufficient size to allow for easy removal of the boiler.

Where the boiler is fitted in a cupboard or compartment, permanent ventilation is not required.

1.15 Timber Frame Building

If the boiler is to be installed in a timber frame building it should be fitted in accordance with the Institute of Gas Engineers document IGE/UP/7/1998. If in doubt seek advice from the local gas undertaking or Hepworth Heating Ltd.

1.16 Anti-theft Kits

Anti-theft kits are available for these appliances, contact Hepworth Heating Ltd. for further information.

2 Flue and Ventilation

The flue must be installed in accordance with the rules in force in the countries of destination.

2.1 Terminal Position

The minimum acceptable siting dimensions for the terminal from obstructions, other terminals and ventilation openings are shown in diagram 2.1. For Ireland the minimum distances for flue terminal positioning must be those detailed in I.S.813 "Domestic Gas Installations".

The terminal must be exposed to the external air, the position allowing free passage of air across it at all times.

Car ports or similar extensions of a roof only, or a roof and one wall, require special consideration with respect to any openings, doors, vents or windows under the roof. Care is required to protect the roof if it is made of plastic sheeting. If the car port consists of a roof and two or more walls, seek advice from the local gas company before installing the boiler.

If the terminal is fitted within 600mm below plastic guttering or painted soffit an aluminium shield 1500mm long should be fitted immediately beneath the guttering or eaves. If the terminal is fitted within 450mm below painted eaves or a painted gutter, an aluminium shield 750mm long should be fitted immediately beneath the guttering or eaves.

2.2 Flue Options

There are various flue systems to choose from, as follows:

- Standard Top Outlet Flue Pack - Pt.No. 230483
- Easyfit Top Outlet Flue Pack - Pt. No. 232057
- Standard Rear Outlet Flue Pack - Pt. No. 230482
- Extended Top Outlet Flue Pack - Pt. No. 230487
- 1 Metre Extension Kit - Pt. No. 230484
- A flue system up to 3 metres in length can be made by connecting 1 metre flue extension kits together.
- Optional Wall Liner Kit No. 900862
- A Flue Bend Kit or Vertical Flue Kit up to 4 metres can be supplied, see Hepworth Heating "Flue Options Guide" for configurations available.
- 45° Flue Bend Pack - Pt. No. 230485
- 90° Flue Bend Pack - Pt. No. 230486
- In Line Flue Adapter Kit - Pt. No. 230488
- Vertical Flue Kit No. 458115

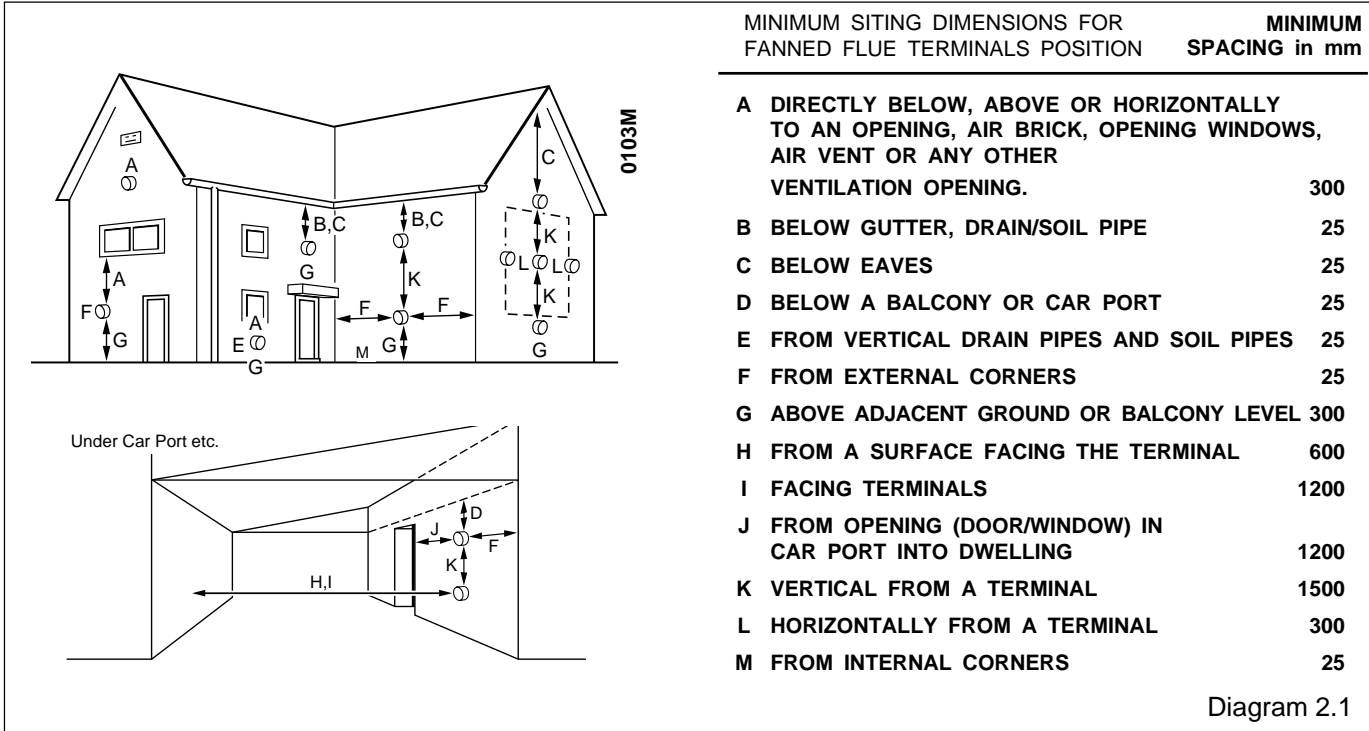

2 Flue and Ventilation

2.3 Terminal Guard

A terminal guard is required if persons could come into contact with the terminal or the terminal could be subject to damage.

If a terminal guard is required, it must be positioned to provide a minimum of 50mm clearance from any part of the terminal and be central over the terminal, see diagram 2.2.

A suitable guard, reference Type "K3", can be obtained from:

Tower Flue Components Ltd.,
Morley Road,
Tonbridge,
Kent.
TN9 1RA

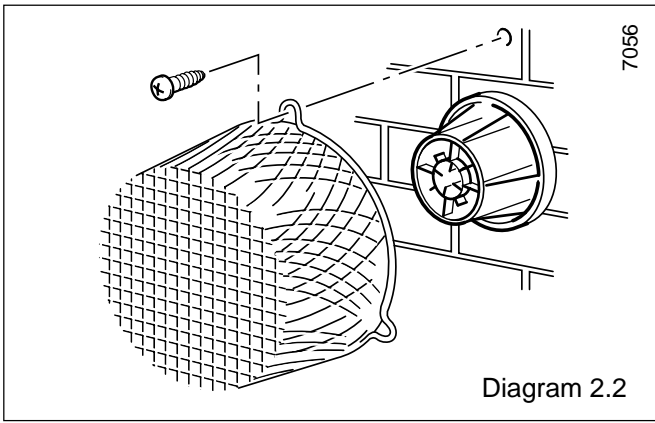

3 Water Systems

The installation of the boiler must comply with the requirements of the current issue of BS6798, in Ireland, refer also to the current edition of I.S.813 "Domestic Gas Installations".

In GB it is necessary to comply with the Water Supply (Water Fittings) Regulations 1999 (for Scotland, the Water Byelaws 2000, Scotland).

To comply with the Water regulations your attention is drawn to: The Water Regulations guide published by the Water Regulations Advisory Service (WRAS) gives full details of the requirements.

In IE the requirements given in the current edition of I.S.813 "Domestic Gas Installations" and the current Building Regulations must be followed.

3.1 Frost Protection

There is a built-in frost stat in this boiler. See Protection Against Freezing in Instructions for Use. Where other parts of the system are vulnerable this should also be considered as specified in the current issue of BS5422.

3.2 Pump

The pump, with integral valves, should be fitted in the heating flow pipework from the boiler, it should be set to produce a temperature difference of 11°C (20°F), between the flow and return, with the boiler thermostat set at "MAX", which is about 82°C (180°F).

The pressure loss of the boiler at 30.6 litre/minute giving 11°C temperature difference is 950mm head of water.

High resistance microbore systems may require a higher duty pump.

3.3 Bypass

A bypass is usually unnecessary on systems using a 3 port diverter valve since one port will remain in the open position at all times. This allows satisfactory operation of the pump overrun.

However if thermostatic radiator valves are fitted to all radiators or two port valves are used a bypass is required.

The bypass connection must be at least 2 metres away from the boiler.

The flow through the boiler must not be allowed to fall such that there is a temperature difference greater than 20°C between the flow and return.

3.4 Water System

For an open vented system the boiler must be supplied from an unrestricted water supply taken from a feed and expansion cistern fitted at a maximum height of 27 metres above the boiler.

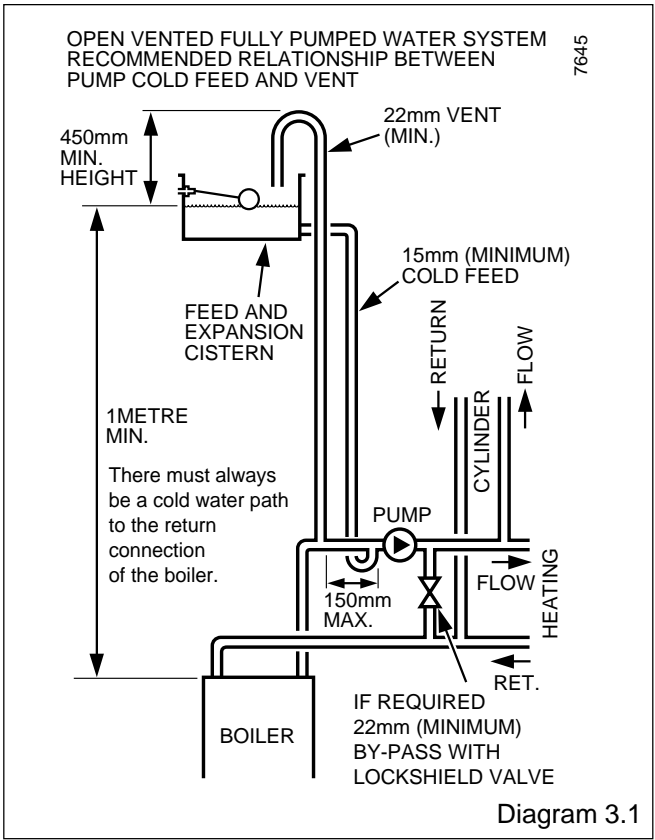

The cold feed must be 15mm minimum size.
It is important that the relative positions of the pump, cold feed and open vent are as shown in diagram 3.1.
The unrestricted open vent from the boiler must rise continuously to discharge over the feed and expansion cistern.

3.5 Domestic Hot Water System

General - All domestic hot water circuits, connections, fittings must be in accordance with the relevant standards and water supply regulations.

For GB: Guidance G17 to G24 and recommendation R17 to R24 of the Water Regulations Guide.

For IE: The current edition of I.S.813 "Domestic Gas Installations".

3.6 Cylinder

For all systems supplying domestic hot water the cylinder must be indirect. It is recommended that the cylinder be fitted with some form of temperature control.

3 Water Systems

3.7 Open Vented Fully Pumped Heating and Domestic Hot Water

The connections for the system MUST be as shown in diagrams 3.1 and 3.2.

Plastic pipes should not be connected directly to the boiler. An intermediate metallic pipe of 1m in length should be fitted between the boiler and the plastic pipe system. Plastic pipes should be type S to BS7291.

3.8 Inhibitor

Attention is drawn to the current issue of BS5449 and BS7593 on the use of inhibitors in central heating systems.

When installing in an existing system take special care to drain the entire system, including radiators, then thoroughly cleaning out before installing the boiler whether or not adding an inhibitor.

3.9 Sealed Water Systems

The installation should comply with the appropriate requirements of the current issue of BS4814, BS5449, BS6759, BS6798 and BS7074 Part 1 and 2.

3.10 Safety Valve

A safety valve must be fitted to a sealed water system.

It shall be preset, nonadjustable with a lift pressure of 3bar, incorporating seating of a resilient material, a test device and a connection for drain.

The drain from the safety valve must be routed clear of any electrical fittings and positioned so that any discharge can be seen.

3.11 Expansion Vessel - Sealed Systems only

A diaphragm type expansion vessel, conforming to the current issue of BS4814 (see also BS7074 Part 1 and 2) must be connected at a point close to the inlet side of the circulating pump, unless laid down differently by the manufacturer.

The expansion vessel volume depends upon the total water system volume and the initial system design pressure. For any system an accurate calculation of the vessel size is given in the current issue of BS7074 Part 1.

Example: For an initial system design pressure of 0.7bar the minimum total vessel volume required is 0.063xTotal System volume.

Note. A higher initial design pressure requires a larger volume expansion vessel.

Guidance on vessel sizing is also given in the current issue of BS5449 and BS7074 Part 1, for IE refer to the current edition of I.S.813 "Domestic Gas Installation".

The charge pressure must not be less than the static head of the system, that is, the height of the highest point of the system above the expansion vessel.

The water content of the boiler is given in Data Table 1.

3.12 Pressure Gauge - Sealed Systems only

A pressure gauge with a set pointer and covering at least the range of 0 to 4bar (0 to 60lb/in²) shall be permanently fitted to the system in a position where it can be seen when filling the system.

3.13 Domestic Hot Water Cylinder

SINGLE FEED INDIRECT CYLINDERS ARE NOT SUITABLE.

The domestic hot water cylinder must be of the indirect coil type. It must be suitable for working at a gauge pressure of 0.35bar above the safety valve setting.

3.14 Domestic Hot Water System - Unvented

Where a storage system will not have a vent to atmosphere the installation must comply with Building Regulations and local Water Company Bye-laws, see also the current issue of BS6700.

If fitting into an existing system the local authority must also be advised.

3.15 Filling a Sealed Water System

Provision for filling the system at low level must be made. The installation should comply with the appropriate requirements of the current issue of BS 5449.

3.16 Water Makeup

Provision must be made for replacing water lost from the system. A make up vessel mounted above the highest point of the system and connected through a non-return valve to the system on the return side of either the hot water cylinder or heating system.

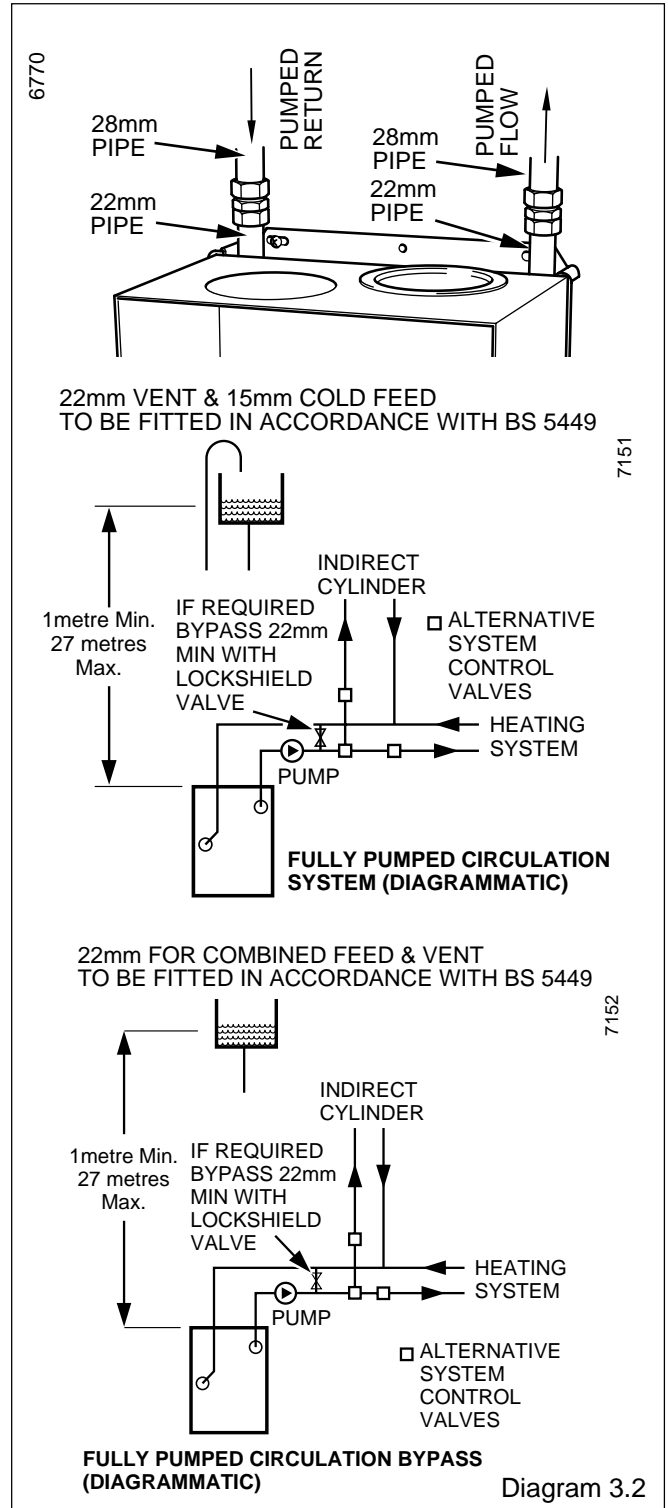

4 Flue and Appliance Preparation

9356

TOP OUTLET FLUE PACK

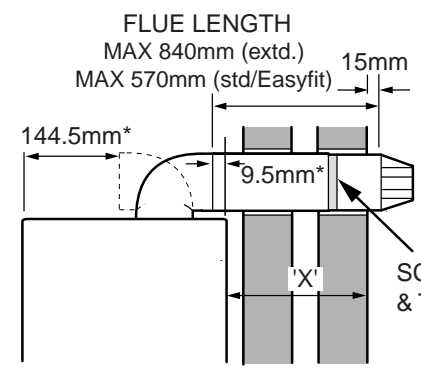

TOP OUTLET/SIDE FLUE

STD/EXTD
'X' plus 24.5mm (RH)
159.5mm (LH) = flue length

EASYFIT
'X' plus 52.5mm (RH)
(must include 50mm min. side clearance)
'X' plus 187.5mm (LH) = flue length

*STD/EXTD flue only

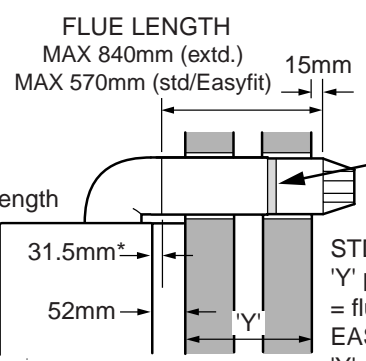

TOP OUTLET/REAR FLUE

STD/EXTD
'Y' plus 35mm = flue length
EASYFIT
'Y' plus 63.5mm = flue length

Note: Outer casing, mounting brackets & boiler details removed for clarity

REAR OUTLET FLUE PACK

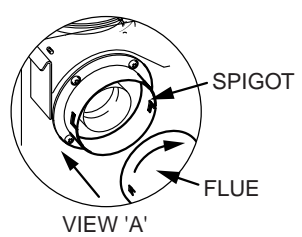

Note: Outer casing, mounting brackets & boiler details removed for clarity

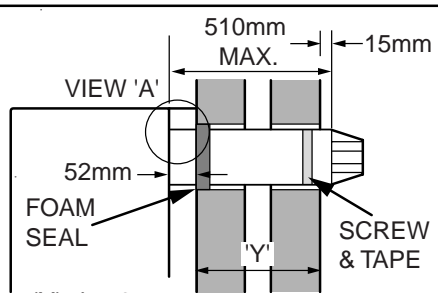

'Y' plus 67mm = FLUE LENGTH

EASYFIT/STD./EXTD. TOP OUTLET FLUE PACK & 1 METRE EXTENSION KIT

1 metre extension kits may be joined together, but the total flue system must not exceed 3 metres.

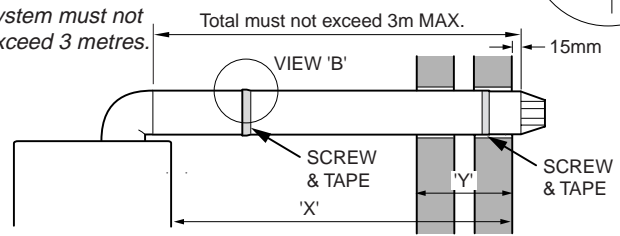

STD/EXTD SIDE FLUE
'X' plus 24.5mm (RH)
159.5mm (LH) = flue length
EASYFIT
'X' plus 52.5mm (RH)
'X' plus 187.5mm (LH) = flue length

STD/EXTD REAR FLUE
'Y' plus 35mm = flue length
EASYFIT
'Y' plus 63.5mm = flue length

STD. REAR OUTLET FLUE PACK & 1 METRE EXTENSION KIT

1 metre extension kits may be joined together, but the total flue system must not exceed 2 metres.

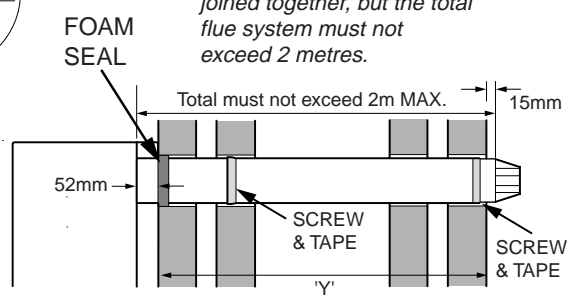

Note: Outer casing, mounting brackets & boiler details removed for clarity

9357

FLUE PACKS	MINIMUM WALL THICKNESS	MINIMUM FLUE LENGTH	MAXIMUM FLUE LENGTH	MAXIMUM DISTANCE FROM	
				"Y" BOILER MOUNTING FACE TO EXTERNAL WALL FACE	"X" BOILER CASING TO EXTERNAL WALL FACE
TOP STD/ EASYFIT					
REAR	75	111	570	535	-
SIDE R.H.	75	102	570	-	546
SIDE L.H.	75	237	570	-	411
TOP EXTD.					
REAR	75	111	840	805	-
SIDE R.H.	75	102	840	-	815
SIDE L.H.	75	237	840	-	680
REAR STD.					
REAR	75	142	510	443	-

NOTE :
IF IT IS NECESSARY TO CUT THE DUCTS TO ACHIEVE THE "FLUE LENGTH" MAKE SURE THAT THE OVERLAPS ARE AS FOLLOWS :-
THE OVERLAP FOR AIR DUCT = 25mm
THE OVERLAP FOR FLUE DUCT = 50mm

Diagram 4.1

4 Flue and Appliance Preparation

NOTE: Make sure that the ductings do not slope down towards the boiler.

4.1 Flue Position and Length

Determine flue application, length and terminal position before starting.

Refer to diagram 4.1.

If you are using a Flue Bend or a Vertical Flue Kit, please follow the instructions supplied with the kit.

To make a neat finish to the flue outlet a flue collar kit, part No. 900850, with instructions, is available, see diagram 4.2.

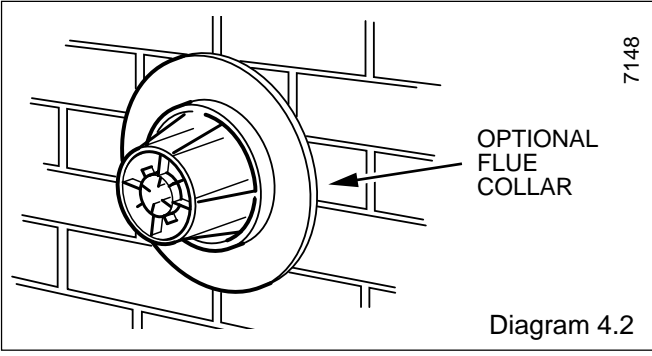

Diagram 4.2

4.2 Flue Preparation

All flue assemblies are designed for internal installation, given that there is sufficient clearances opposite to the flue for the installation of the flue.

If there is insufficient clearance the flue can be installed from outside.

For a wall thickness up to 300mm and provided that there is sufficient space an optional wall liner kit is available for the flue to be installed from the inside.

For a wall thickness of over 300mm the external flue hole will need to be made good from the outside.

This applies also if you use the flue kit without the optional wall liner kit, irrespective of wall thickness.

4.3 Rear and Side Flue Application

Select the boiler location and flue application, with due regard to the terminal position, see diagram 2.1.

Take the template from the boiler pack and temporarily position it on the wall, making sure that the minimum clearances are maintained, see diagram 4.3.

Mark the centre line position of the flue, "Top" or "Rear" as diagram 4.3.

For a side flue, extend centre line of "Top" to L.H. or R.H. corner. Mark the position of the centre of the flue and boiler, as diagram 4.3.

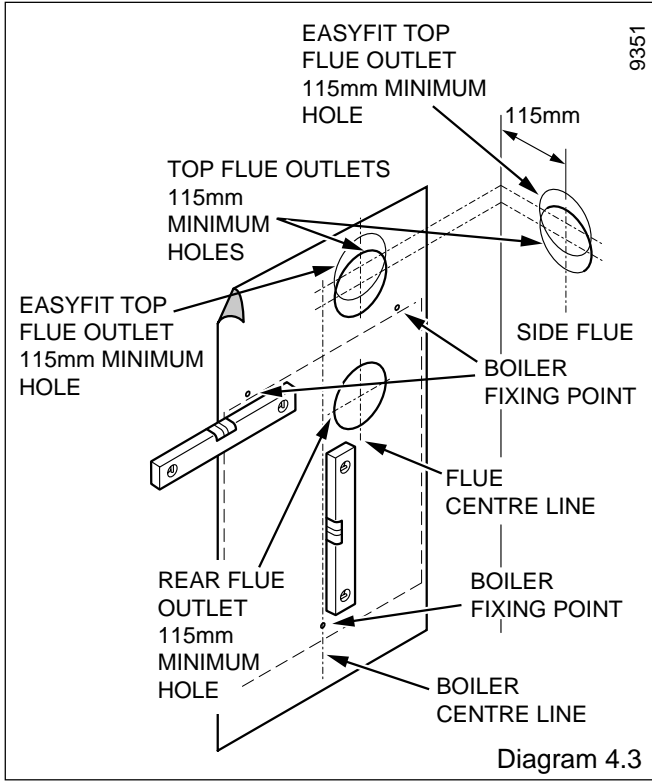

Diagram 4.3

4.4 Flue Hole Cutting

Having marked out the flue centre cut a hole for the flue using, preferably, a 115mm minimum core drill.

Note: If required an optional wall liner kit, part no. 900862, is available complete with instructions.

4.5 Wall Mounting Bracket

Reposition the template, making sure of dimensional alignment with the flue hole.

Mark the boiler fixing points and mounting bracket positions, see diagram 4.4.

Note: The lower mounting bracket is fixed to the boiler.

Drill the holes and insert wall plugs.

Secure the top mounting bracket to the wall with two No. 12x2in wood screws one on each side of the bracket, see diagram 4.4.

Alternative fixing positions are provided in the bracket, if required.

4.6 Flue Duct

Extend the telescopic flue to the required length, making sure that the minimum overlap is no less than 25mm, and that the flue terminal projects 15mm minimum beyond wall face, see diagram 4.1.

Carefully drill through air duct pilot hole and secure with self tapping screw provided in fittings pack, see diagram 4.1.

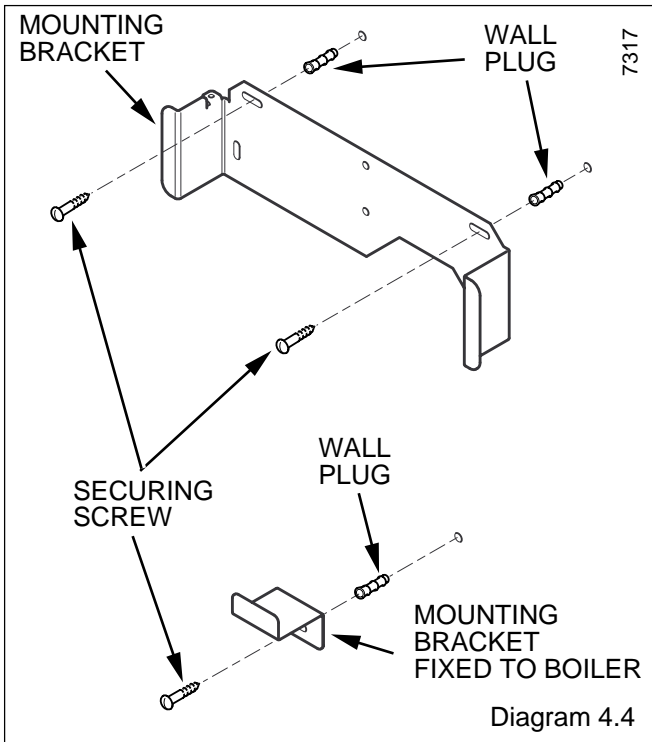

Diagram 4.4

4 Flue and Appliance Preparation

Seal the joint with the tape provided.

If the flue system requires the addition of flue extension kits, drill, seal and secure them with the self tapping screw and tape provided. The completed flue system must not exceed 3metres, see relevant part of diagram 4.1.

Note: Should any one of the flue sections require cutting to obtain desired flue system length, cut the 1 metre extension kit at the end opposite the expanded end.

Make sure to cut square and remove any burrs.

If the boiler is not to be fitted for some time cover the hole in the wall.

Note: If a horizontal flue extension is required it must be used in conjunction with the standard flue, see diagram 4.1.

IMPORTANT: When using the standard flue kit (either rear outlet or top outlet fixing) or Easyfit, the terminal restrictor must be fitted. This is not fitted for any other flue type/ arrangement, extension kits etc.

Note: There are three restrictors in the loose items pack, use the one stamped "D" for the Micron 70FF.

Take the terminal restrictor and position the clamping bracket making sure the clamping bracket nib protrudes in the slot of the terminal restrictor and secure with locking screw, but do not tighten, see diagram 4.6.

Engage the terminal restrictor on the flue terminal by hooking it over the terminal end and engaging the clamping bracket behind the inner ring of the terminal securing it by tightening the locking screw, see diagram 4.6

4.7 Internal Access Flue

If access to the outside wall is not practical, the flue system can be installed from inside. Use of the optional wall liner kit is required.

4.8 Rear Flue Fixing

Fit the self adhesive foam seal provided in the flue pack around the air duct at the position shown in diagram 4.1.

Make sure that the ductings do not slope down towards the boiler.

Make good around the flue outside after installation of boiler.

Important: If the wall liner kit is used, the self adhesive foam seal included must be used in place of the one supplied with the flue pack, see diagram 4.5 for position of self adhesive seal.

4.9 Top, Side Flue Fixing

Make sure that the ductings do not slope down towards the boiler.

Make good the area around the flue, inside and outside, after installation of the boiler.

Important: If the wall liner kit is used, the self adhesive foam seal included must be used in place of the one supplied with the flue pack, see diagram 4.5 for position of self adhesive seal.

4.10 Flue Positioning

Push the flue assembly into the hole such that it is within the wall and does not stick out into the room. Do not push the flue assembly too far into the hole as it has to be pulled back into the boiler and secured.

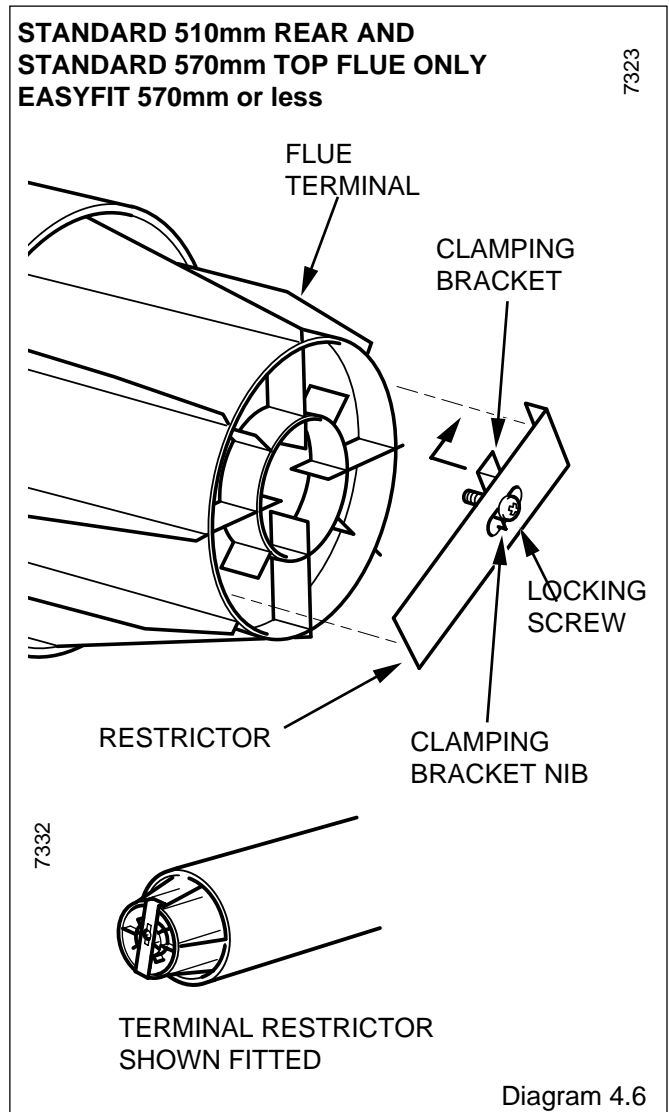
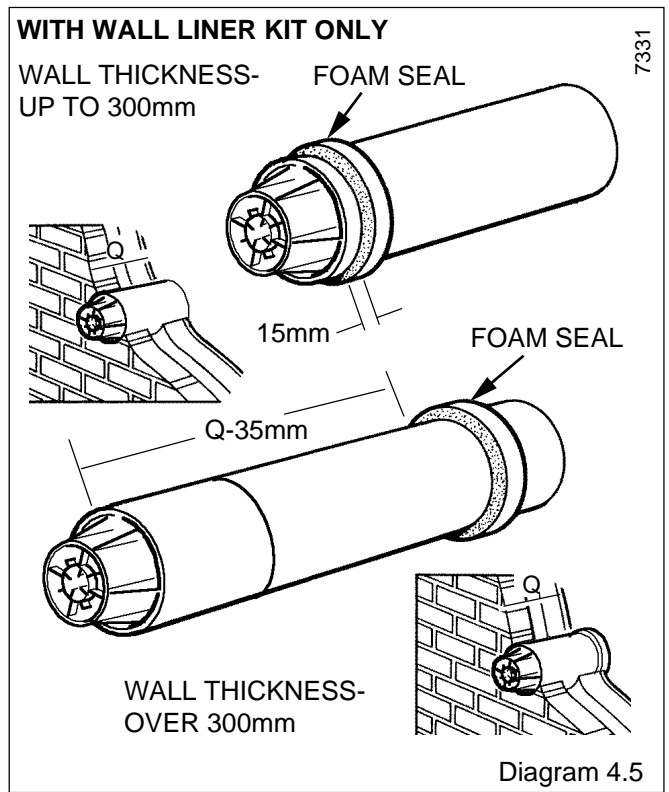

5 Boiler Installation

5.1 Unpacking

Open the carton, check the items supplied against the boiler pack contents list on the carton flap.

5.2 Boiler Preparation

With the boiler still in the bottom tray, remove the casing front cover. Open the controls cover first, then by undoing the two screws at the bottom and the one at the top, lift the front cover off, see diagram 5.1.

Place front cover in a safe place on one side until required.

Remove boiler.

From the fittings pack, slide a tubing nut and washer on to the return and flow tail pipes which are supplied with the boiler, see diagram 5.2.

Connect the return and flow tail pipes to the boiler, see diagram 5.2.

Fit suitable compression fittings to the tail pipes.

For pipework entering the boiler from below, an optional flow and return pipe incorporating an air vent is available, kit No. 458585, see diagram 5.3.

Note: If the installer wishes to adapt the standard pipework he may do so, but must incorporate an air-vent at the highest point on the flow pipe and the highest point of the return pipe, see diagram 5.11.

5.3 Mounting the Boiler

Ensure to fit the blanking plate and gasket on the boiler flue outlet not being utilised, see diagram 5.6.

If the rear flue outlet is to be utilised for the installation of the flue, it will be necessary to connect the flue spigot and gasket to the outlet using self-tap screws provided, see diagram 5.6.

Note: The spigot would only be fitted to the top flue outlet where a vertical flue kit or in certain flue bend orientations is incorporated. Instructions are supplied with these kits.

Lift the boiler into position, hooking over the top mounting bracket.

Note: Anti-theft screw kits are available, part no's: 458113 and 458114.

Important: Secure lower bracket to wall with screw into wall plug already prepared.

Note: It will be necessary to move the control box to access the bracket by slackening its retaining screw and swinging it out on its hinge, see diagram 5.10.

Where the boiler is located in a restricted place, see diagram 1.3 in Instructions for Use, it may be necessary to remove the control knob to enable the control box to be fully swung out.

If the top flue outlet is to be utilised, secure the top turret and gasket or flue spigot and gasket depending on desired flue orientation in position with the 2 taptite and 2 self-tap screws provided, see diagram 5.9.

Note: Ensure that the taptite and self-tap screws are positioned as shown in diagram 5.8 to enable the air deflector to be fitted correctly.

If fixing to the back of the boiler, i.e. spigot, slide the flue into the spigot until it engages in the bayonet connection and then twist clockwise to lock, see diagram 4.1.

Make sure the fitting of the flue to the boiler is correct.

The fan assembly may also be removed or slid forward about halfway out of the boiler, to ease access.

Disconnect the the blue and purple electrical connections to the fan, and the air pressure switch tube connections, see diagram 5.5.

Note: Remove the electrical connections by pulling insulation boots only.

Remove the securing screw at the front, see diagram 5.5.

The fan assembly may now be slid forward.

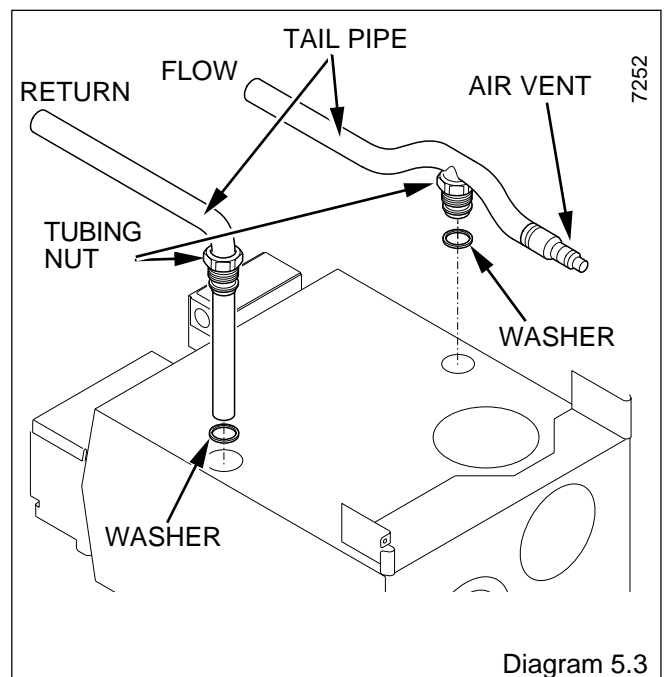
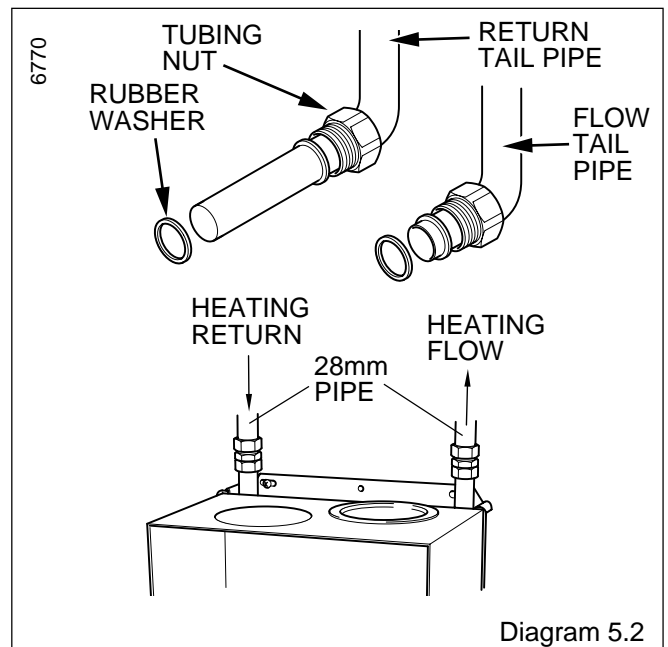
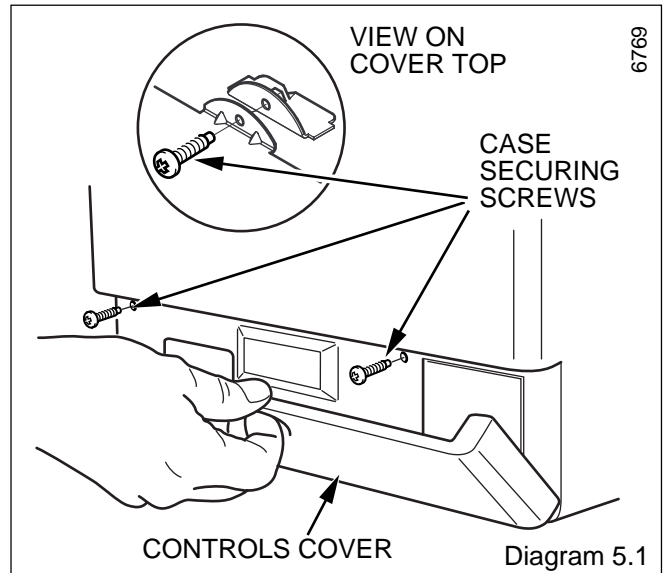

5 Boiler Installation

Rear Flue fixing.

Fit the fan elbow and secure with jubilee clip to the fan outlet, do not tighten yet, see diagram 5.7.

Fit the retaining clamp of the fan elbow, bending the straps around the fan elbow raised clamping surfaces but do not fasten the clasp, see diagram 5.7.

It is important that the retaining clamp is fitted the correct way round, so that the straps locate on to the fan elbow raised clamping surfaces.

Reconnect the blue and purple electrical connections to the fan, the polarity of the connections is not important.

Pull the flue duct into the fan elbow to engage.

Important: It is essential to make certain that the flue duct is fully located into the fan elbow until it can go no further.

Fasten the fan elbow retaining clamp clasp thus securing it, see diagram 5.7.

Secure the fan elbow to the fan outlet with the Jubilee clip.

Reposition fan assembly.

Top flue fixing

Fit the two "O" rings from the loose items pack onto the flue duct extension, there are recesses on the flue duct extension for locating them, see diagram 5.7.

Fit the air deflector in position using the rear left hand taptite screw and the one diametrically opposite which hold the top turret and secure with the wing nuts provided, see diagram 5.8.

Note: Apply soap to seals on flue duct extension piece to help it slide on, be careful not to damage 'O' ring.

Insert flue duct extension piece into top turret, see diagram 5.7.

Note: Make sure that the flue duct extension piece is positioned so that the ribs are upper most, see diagram 5.7.

Locate the fan elbow with jubilee clip on the fan outlet, do not tighten yet, see diagram 5.7.

Reconnect the blue and purple electrical connections to the fan, the polarity of the connections is not important.

Reposition the fan assembly and draw down the flue duct extension piece onto the fan elbow, see diagram 5.7.

Fit the retaining clamp of the fan elbow, bending the straps around the fan elbow raised clamping surfaces and fastening the clasp thus securing it to the flue duct extension, see diagram 5.7.

It is important that the retaining clamp is fitted the correct way round, so that the straps locate on to the fan elbow raised clamping surfaces.

Secure the fan elbow to the fan outlet with the Jubilee clip.

Continued.

Secure the fan assembly by replacing securing screw, see diagram 5.5.

Reconnect the air pressure switch tubes, ensuring they are in the correct orientation, as shown in diagram 10.7.

5.4 Water Circulation System

Complete the water connections to the boiler.

Fill, vent and flush the system.

Check for any water leaks and put right.

5.5 Gas Connection

Make the gas connection to the Rc¹/₂in gas service cock, see diagram 6.2.

The whole of the gas installation, including the meter, should be inspected, tested for soundness and purged in accordance with the current issue of BS6891 and in IE the current edition of I.S.813 "Domestic Gas Installation".

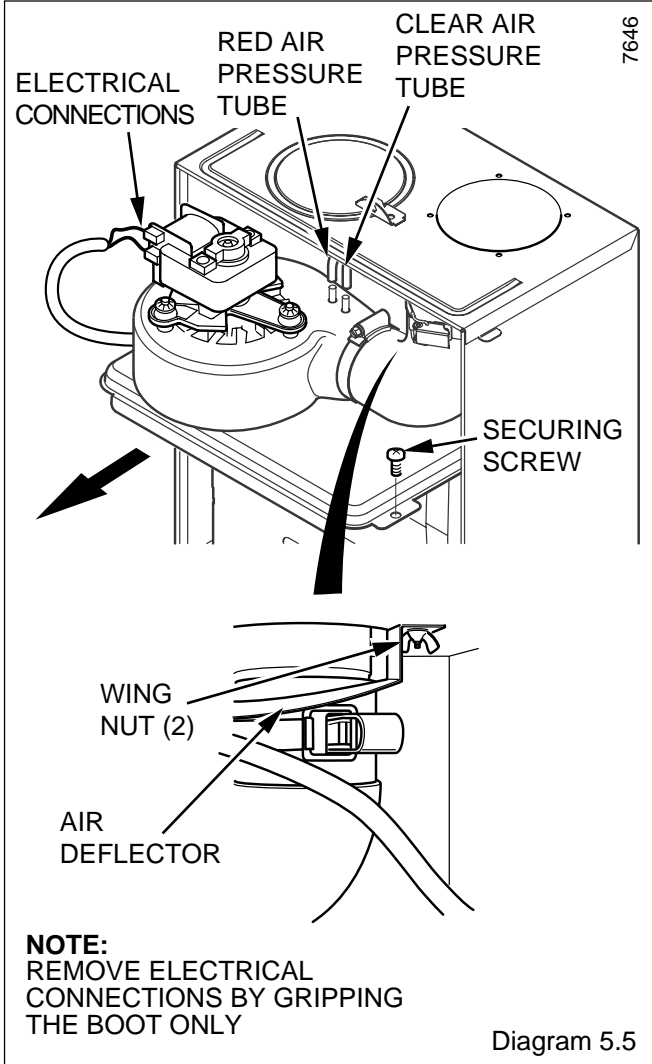
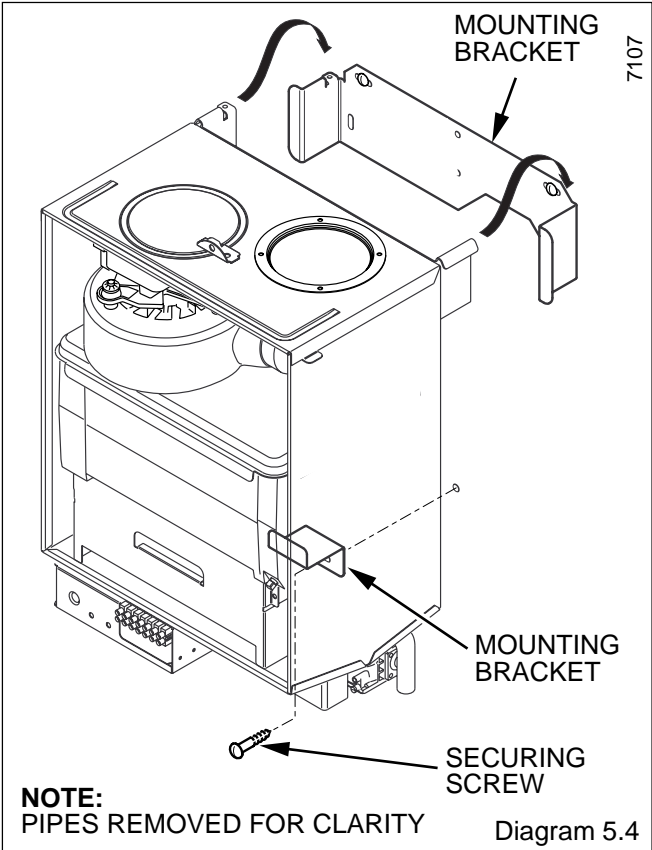

5 Boiler Installation

5.6 Control Box Access

Slacken the control box securing screw, see diagram 5.10. Swing the box out on its hinge.

5.7 Electrical Connection

WARNING. This boiler must be earthed.

Note: If an optional programmer is to be installed, it should be fitted at this stage, see separate installation instructions supplied with programmer

Take care not to damage any internal wiring.

Using heat resistant (85°C) cable of at least 0.75mm² (24/0.2mm) and of a suitable length, thread through the grommet at the rear of the control box, through the cable clamp and connect to appropriate terminals. Tighten cable clamp screws, see diagram 5.10.

Standard colours are, brown - live (L), blue - neutral (N) and green/yellow - earth (⊕).

The mains cable outer insulation must not be cut back external to the cable clamp.

Make sure the cable is suitably secured.

When making connections, make sure that the earth conductor is made of a greater length than the current carrying conductors, so that if the cable is strained the earth conductor would be the last to become disconnected.

5.8 Pump Connection

Route pump cable as mains, see diagram 5.10.

Connect to control box terminal block, see diagram 9.5.

5.9 Testing

Checks to ensure electrical safety must be carried out by a competent person.

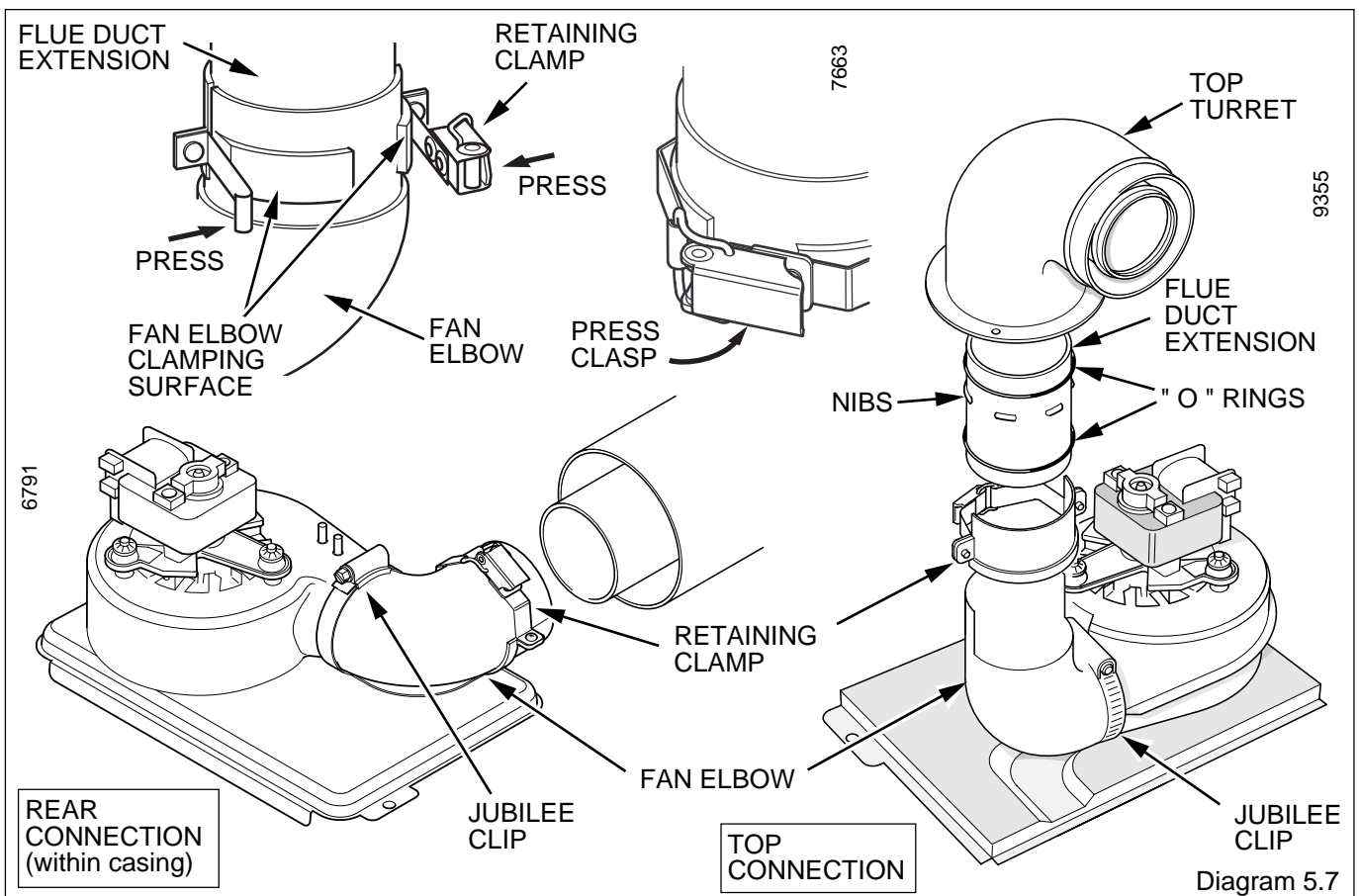
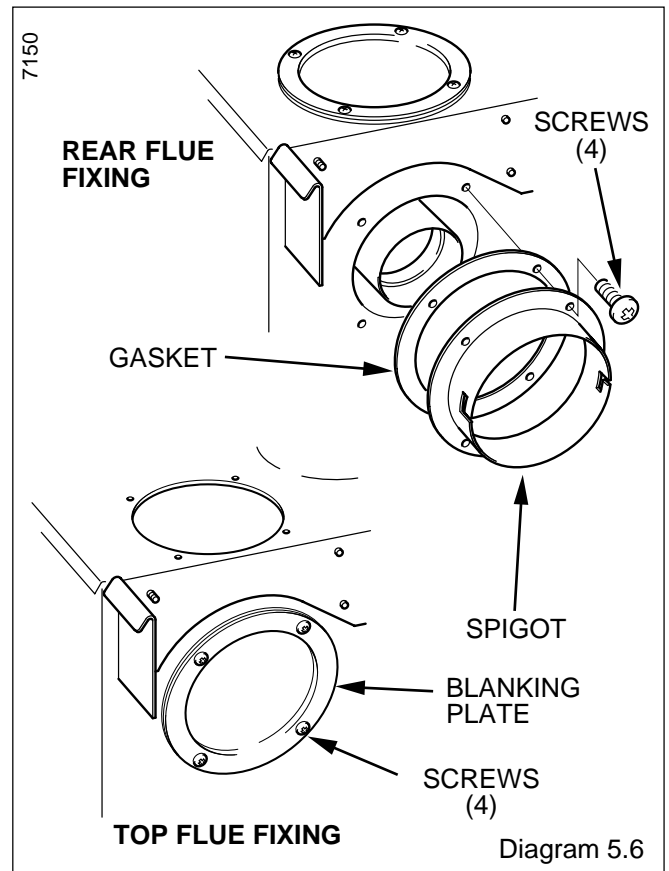

5 Boiler Installation

After installation of the system, preliminary electrical system checks as below should be carried out:

1. Test insulation resistance to earth.
2. Test earth continuity and short circuit of all cables.
3. Test the polarity of the mains.

The installer is requested to advise and give guidance to the user of the controls scheme used with the boiler.

Fit the casing.

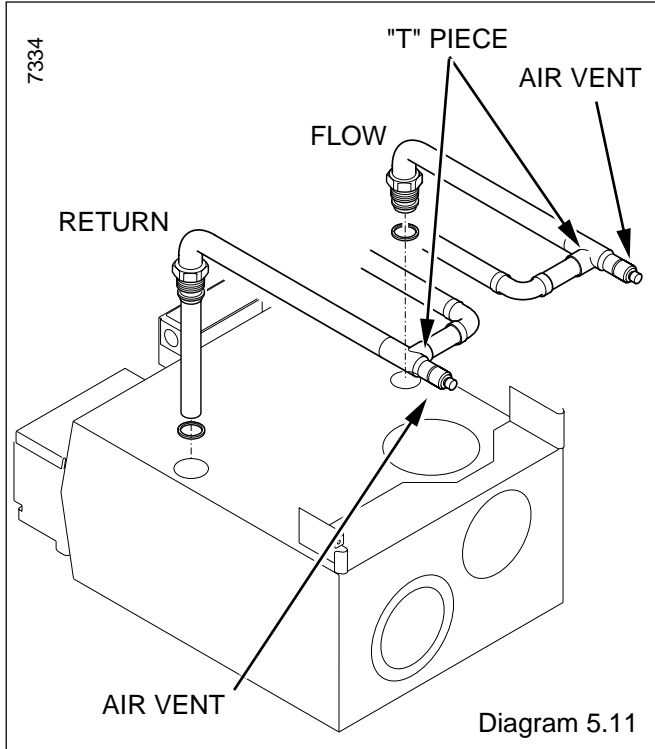
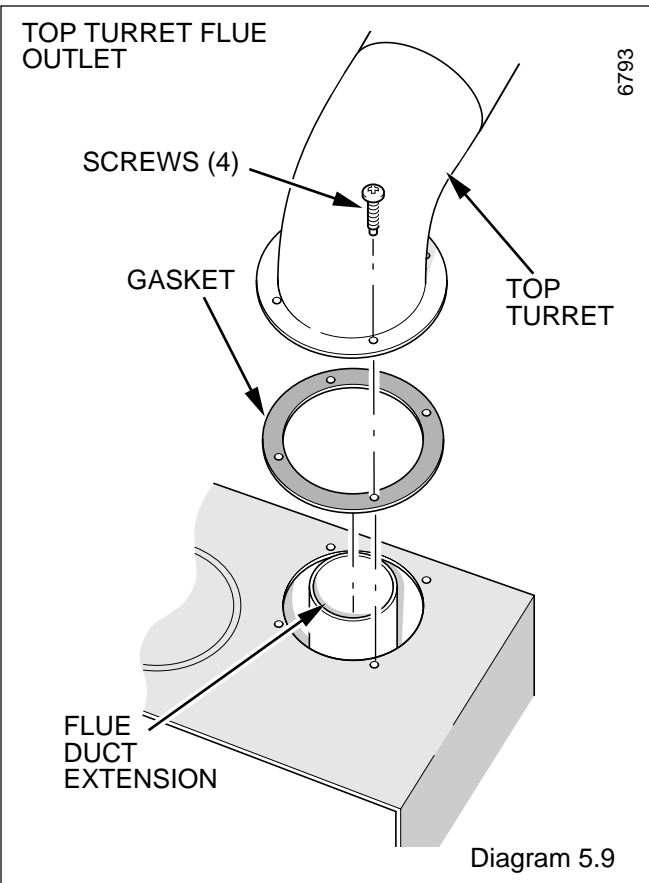
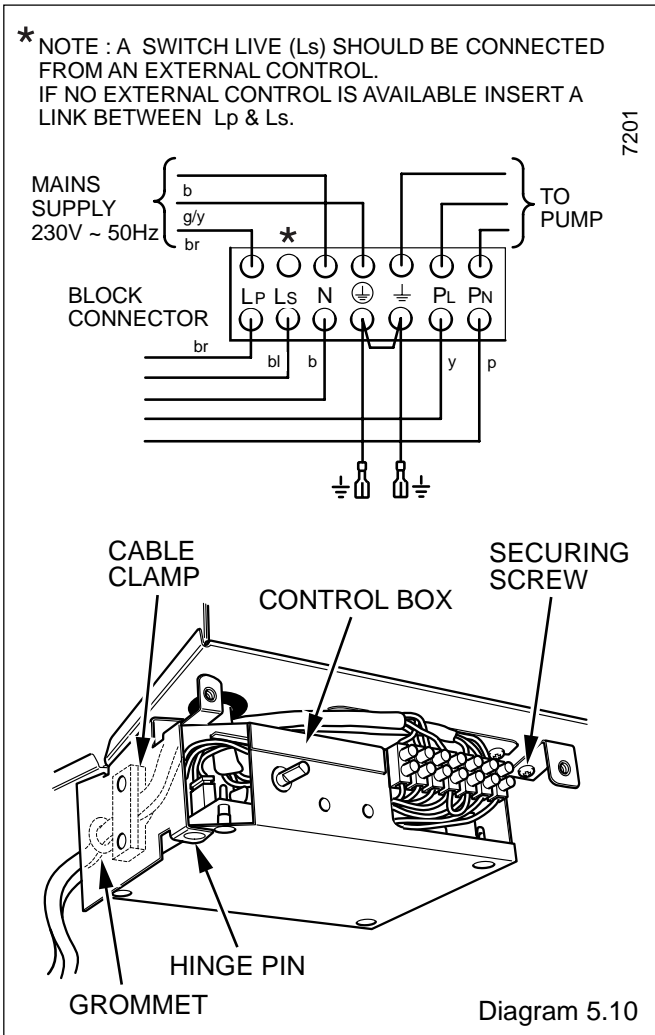
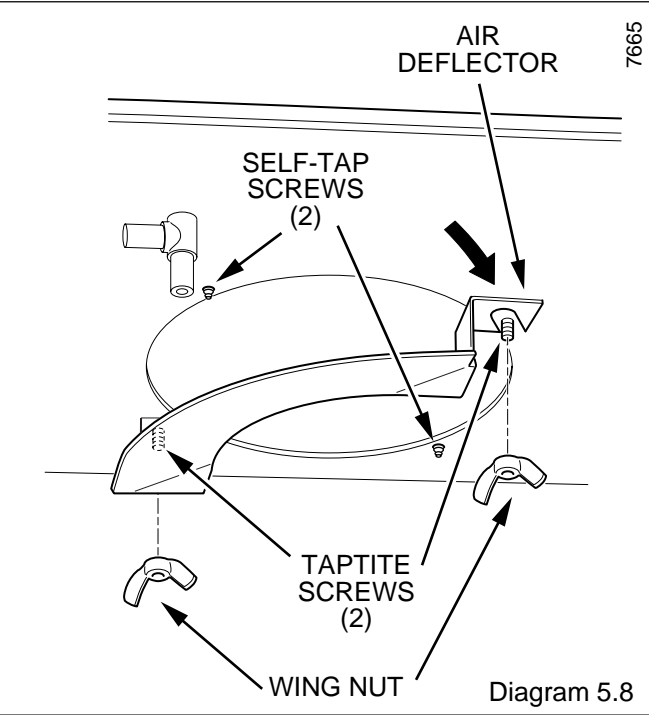

6 Commissioning

Important Note: The warning notice attached to the front of the boiler casing must only be removed by the user.

Please ensure the "Benchmark" logbook is completed and left with the user.

6.1 All Systems

Commissioning should be carried out by a competent person in accordance with the current issue of BS6798.

UNDER ALL CIRCUMSTANCES the case must be correctly fitted and sealed, unless fault finding.

Make sure that the system has been thoroughly flushed out with cold water without the pump in place.

Refit the pump, fill the system with water, ensuring that all the air is properly vented from the system and pump.

6.2 Sealed Water Systems Only

Fill until the pressure gauge registers 2.7bar (40lbf/in²). Clear any air locks and check for water soundness.

Check the operation of the safety valve, by allowing the water pressure to rise until the valve opens. The valve should open within +/- 0.3bar (+/- 4.3lbf/in²) of the pre-set pressure. Where this is not possible conduct a manual check and test.

Note: Fit a suitable discharge pipe to the safety valve and route it to outside the building so that any discharge can be seen but will not cause injury to persons, damage to property or any electrical installation.

Release cold water to initial system design pressure.

The set pointer on the pressure gauge should be set to coincide with the indicating pointer.

6.3 Initial Lighting and Testing

CAUTION. This work must be carried out by a competent person, in accordance with the current issue of BS6798.

Make sure that boiler case is fitted securely

Make sure that all naked lights and cigarettes are out.

Open the control cover, refer to the 'Instructions for Use' and identify the controls, see diagram 9.1.

Remove fascia, see diagram 6.1.

Check that the boiler is isolated from the electrical supply.

Make sure that the temperature control is turned to the "0" "Off" position, see diagram 9.1.

Undo the screw which holds the control box, refer to diagram 5.10. Swing open control box.

Turn the gas service cock "On", see diagram 6.2. A 14mm spanner may be required for this.

Purge in accordance with the current issue of BS6891.

Replace control box.

Turn on the electrical supply.

WARNING. The multifunctional control and fan operate on mains voltage, terminals will become live.

If programmer control fitted, make sure it is in the ON mode.

Note: If the programmer is manually switched on then off when the boiler is cold, the boiler may continue to operate for about 30 seconds before switching off.

Make sure that any remote controls are calling for heat.

Turn the temperature control clockwise to "Max".

The ignition system will operate to light the boiler. After a pre-set time if ignition has not taken place the boiler will shutdown.

To re-start the lighting sequence, turn the temperature control to "0", then fully clockwise to "Max".

After the burner has lit, the "Burner on" neon on the control panel will come on.

Isolate the boiler from the electrical supply.

Loosen the burner pressure test point screw and connect a suitable pressure gauge, see diagram 6.2.

Replace control box.

Switch on the electrical supply to the boiler.

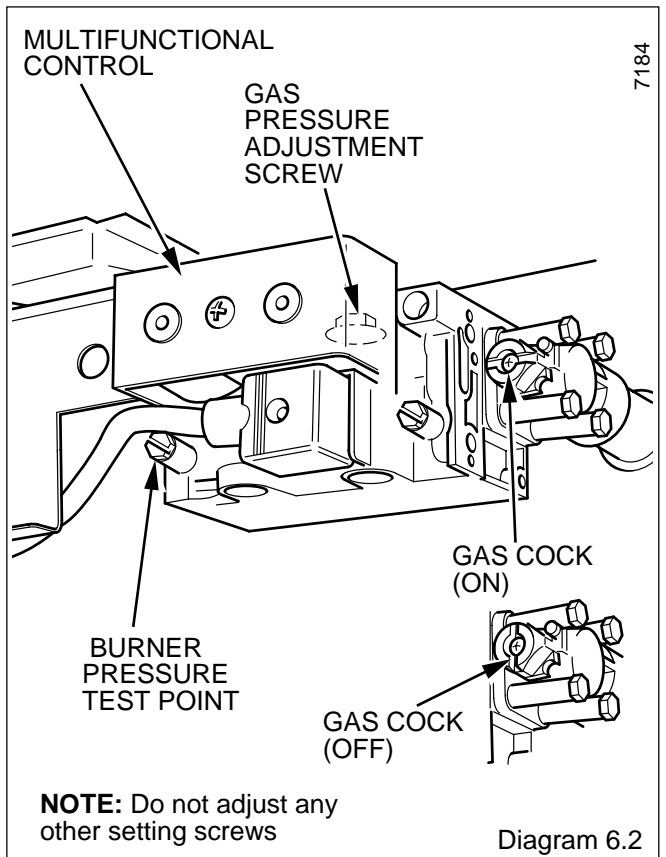
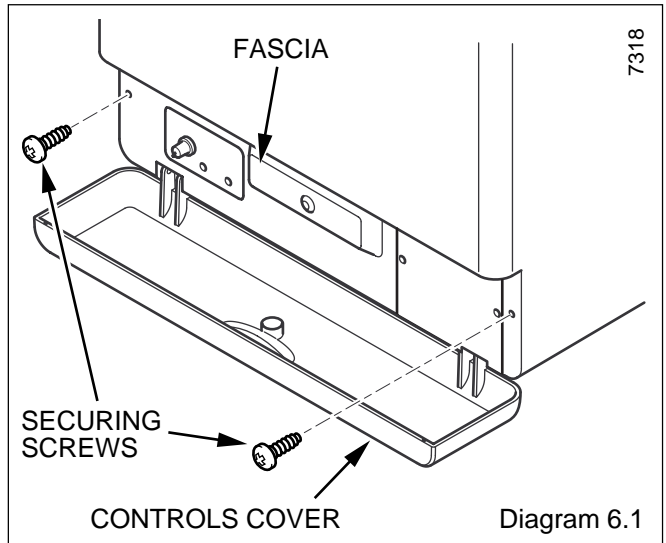

6 Commissioning

6.4 Testing - Electrical

Turn the boiler temperature control knob fully clockwise to the maximum setting, which is approx. 82°C (180°F).

The lighting sequence is automatic as follows:

The fan will operate for 10 seconds prior to the start of the ignition sparks, the gas valve solenoids will open and the burner will light. This is shown by the "Burner Lit" LED on the control panel lighting up.

The burner will stay alight until switched off, either by the temperature control or remote system control. At this point the fan will overrun by 5 seconds.

To make sure that the flame supervision device is working correctly the following should be done.

With the burner alight, turn the gas service cock "OFF", see diagram 6.2.

After a short period the burner will go out and fan will overrun for 5 seconds.

The correct working of the flame supervision device is shown by the "Burner Lit" LED going out and the lighting sequence starting up, as follows:

1. Fan starts.
2. Spark ignition operates for 10 seconds.
3. Fan will overrun for 5 seconds.
4. The fan will start again.
5. After 10 seconds the spark ignition operates, this continues for a further 10 seconds.
6. Fan will overrun for 5 seconds.

This sequence is repeated ONCE more and the boiler will shut down. The following illumination will happen with the LED on the front of the control panel, "Reset" permanently ON and "Burner Lit" flashing fast (8 Hz).

If the above lighting sequence fails, refer to section 9 - Fault Finding.

To continue, turn the gas service cock "On", see diagram 6.2.

To restart the lighting sequence, turn the temperature control knob to "O" then fully clockwise to "Max".

During Normal Operation when the boiler switches "Off", the burner will go out. The automatic lighting sequence will work again when heat is required.

6.5 Testing - Gas

With the boiler on proceed as follows:

Undo the screw which secures control box, see diagram 5.10.

Open control box, see diagram 5.10.

WARNING. The multifunctional control and fan operate on mains voltage, terminals will be live.

Test for gas soundness around the boiler gas components using a suitable leak detection fluid, in accordance with the current issue of BS6891.

Check the main burner gas pressure at least 10 minutes after the boiler has lit, refer to Data Label.

If necessary remove cap then adjust the gas pressure to obtain the required setting turning screw clockwise to decrease pressure, see diagram 6.2.

Replace cap.

Should any doubt exist about the gas rate, check it using the gas meter test dial and stop watch, at least 10 minutes after the burner has lit, making sure that all other gas burning appliances and pilot lights are off.

Table 2				
70FF		MIN.	MED.	MAX.
APPROX.	m ³ /h	2.05	2.21	2.34
GAS RATE	ft ³ /h	72.3	77.9	82.5

The gas rates shown in Table 2 are for guidance only, dependent on the heat setting.

Turn the temperature control knob fully anticlockwise to "O". Isolate from electrical supply.

Remove the pressure gauge from the test point and refit screw, making sure a gas tight seal is made.

Refit control box and fascia.

Note: The fixing holes of the fascia are slotted to allow fine adjustment to align control cover with casing.

When the temperature control is turned to the "O" position, by hand, wait at least 30 seconds before turning On again.

There may be an initial smell given off from the boiler when new, this is quite normal and it will disappear after a short period of time.

6.6 Testing - All Water Systems

Allow the system to reach maximum working temperature and examine for water leaks.

There should be no undue noise in the system.

The boiler should then be turned off and the system drained off as rapidly as possible, whilst still hot.

Refill system.

6.7 Open Vented System

Ensure there is no pumping over of water or entry of air at the open vent above the feed and expansion cistern.

6.8 Adjustment - Fully Pumped Open Vented and Sealed Water Systems

When commissioning the system the boiler should first be fired on full service, that is, central heating and domestic hot water. Adjust the pump to the system design setting then balance the system, making adjustments as necessary.

6.9 Thermostatic Radiator Valves

If thermostatic radiator valves are fitted care must be taken to ensure that there is an adequate flow rate through the boiler when they close, refer to the current issue of BS7478 for guidance. If fitted to all radiators ensure a bypass is fitted and adjust to achieve a temperature difference no greater than 20°C between flow and return with the thermostatic valves closed.

6.10 Completion

Adjust the boiler temperature control and any system controls to their required settings. In addition it is necessary to complete the "Benchmark" logbook.

For IE, it is necessary to complete a "Declaration of Conformity" to indicate compliance to I.S.813. An example of this is given in the current edition of I.S.813.

7 Instructions to the User

Instruct and demonstrate the safe and efficient operation of the boiler, heating system and domestic hot water system.

Advise the user, that to ensure the continued efficient and safe operation of the boiler it is recommended that it is checked and serviced at regular intervals. The frequency of servicing will depend upon the particular installation and usage, but in general once a year should be enough.

Draw attention, if applicable, to the current issue of the Gas Safety (Installation and Use) Regulations, Section 35, which imposes a duty of care on all persons who let out any property containing a gas appliance in the UK.

The user shall not interfere with or adjust sealed components.

It is the Law that servicing is carried out by a competent person.

Advise the user of the precautions necessary to prevent damage to the system and building in the event of the heating system being out of use during frost and freezing conditions.

Reminder - Leave these instructions and the "Benchmark" logbook with the user.

8 Servicing

REMEMBER, When replacing a part on this appliance, use only spare parts that you can be assured conform to the safety and performance specification that we require. Do not use reconditioned or copy parts that have not been clearly authorised by Hepworth Heating Ltd.

Products of Combustion Check

Note: To obtain a products of combustion reading, remove the cap from the sampling point, located on top of the inner casing, see diagram 8.1.

Connect the analyser tube onto the nipple.

Switch on the electrical supply and gas supply then operate the boiler.

On completion of the test switch off the electrical supply and the gas supply, remove analyser tube and replace sampling point cap.

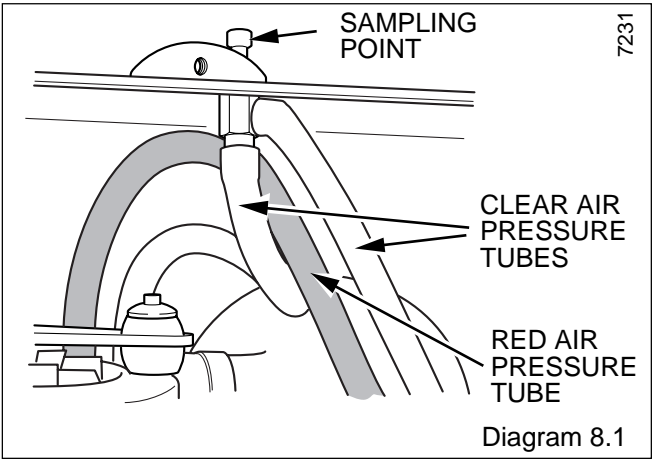

Servicing

Before servicing turn off the gas and isolate the electrical supply to the boiler.

After completing a service always test for gas soundness, make electrical checks and carry out functional check on controls.

Unless stated otherwise all parts are replaced in the reverse order to removal.

8.1 Access

Remove the boiler case, see diagram 5.1 and Section 5.2.

8.2 Burner

Remove front combustion chamber cover which is secured by two screws, see diagram 10.5.

Remove electrode bracket by undoing screw and withdrawing off locating pin, see diagram 8.5.

The HT lead and earth lead (still connected) will allow electrode to hang down at the front of the appliance.

Remove control box retaining screw and swing control box out, see diagram 5.10.

Remove burner retaining screws, located under boiler casing, see diagram 8.3.

Pull out burner together with the baffle support, see diagram 8.3.

To remove baffle support from burner, slide off retaining pins see diagram 8.3.

Use a vacuum cleaner or suitable stiff brush to clean the burner thoroughly, making sure that all the burner ports are clear and unobstructed.

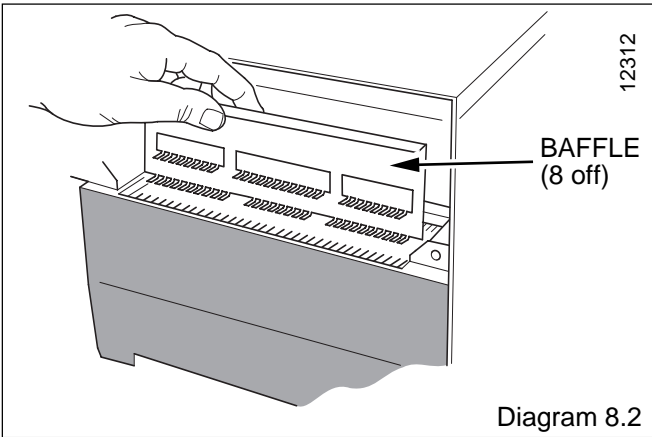

On refitting and after cleaning the heat exchanger make sure the burner is fitted correctly, that is, located on the injector manifold pins and horizontal, see diagram 8.4.

Note: It is advisable while servicing the burner to check the combustion insulation and replace if damaged, see Section 10.10.

8.3 Cleaning Heat Exchanger Flueways

Disconnect the air pressure switch tube connections, red from fan, both clear tubes from test nipple, see diagram 8.1.

Remove the blue and purple electrical connections from the fan see diagram 5.5.

Remove the fan assembly complete with the flue elbow, see diagram 5.5 and Section 5.3.

Place a sheet of paper in the base of the combustion chamber and over the injectors to prevent particles entering.

Remove the baffles, see diagram 8.2.

Clean the heat exchanger flueways with a suitable stiff brush.

Remove the paper together with any debris.

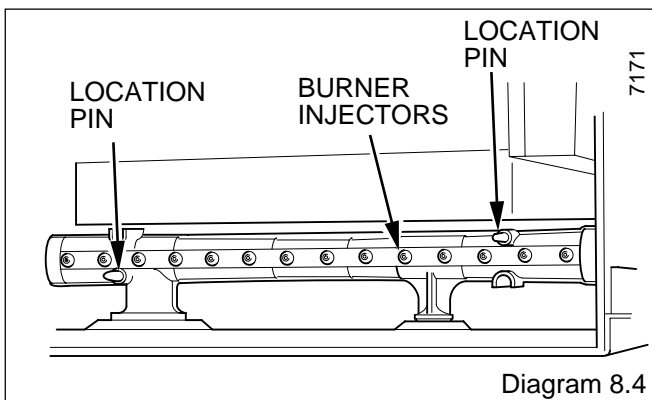
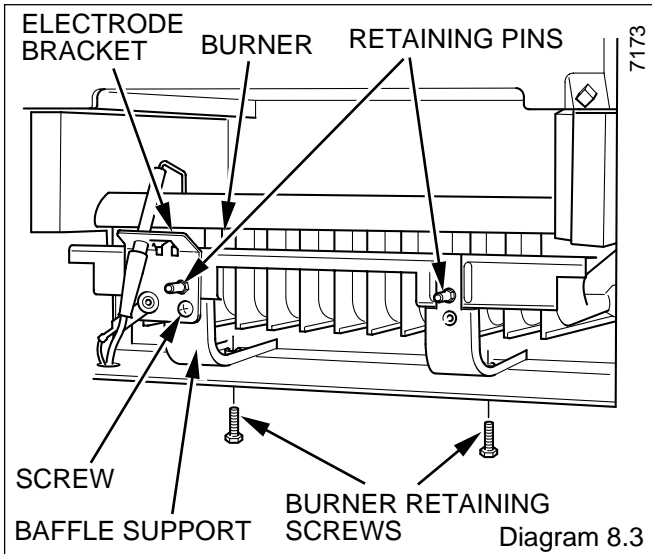

8 Servicing

Important: Where the flue has a rear connection (from back of casing), see diagram 5.6, it is essential to make certain that the flue duct is fully located into the fan elbow until it can go no further, enabling the flue duct to make a complete seal when secured.

8.4 Injector Manifold

With the burner removed the injector manifold can be inspected and cleaned as necessary, see diagram 8.4.

For cleaning do not use a wire or sharp instrument on the holes.

If any injectors are removed, use a little suitable sealant on the external thread when refitting to make sure a gas tight seal is made.

8.5 Operational Checks

After completing a service and before fitting the case, check condition of the case seal and renew if necessary.

Examine flue hood and terminal to make sure they are clean and clear of obstructions.

Refit all parts.

Light the boiler and carryout the functional checks as described in Section 6.

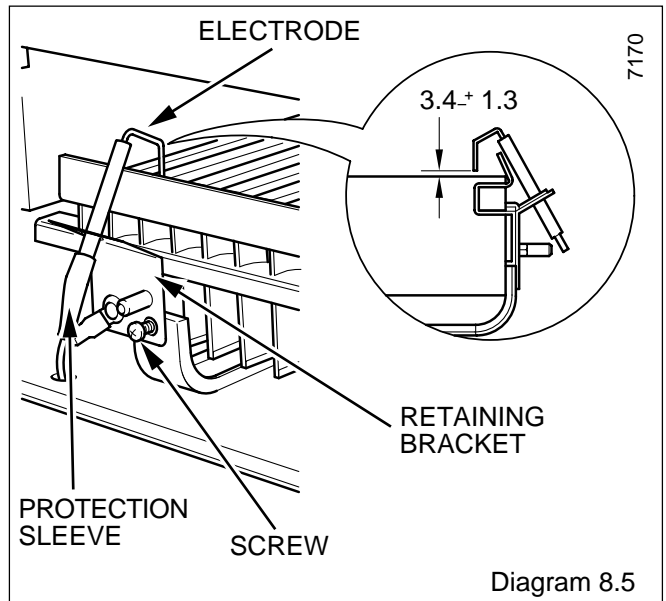

9 Fault Finding

9.1 Electrical

Important. On completion of the Service/Fault Finding task which has required the breaking and remaking of the electrical connections the earth continuity, polarity, short circuit and resistance to earth checks must be repeated using a suitable multimeter.

Refer to: Boiler Fault Finding, see diagram 9.3, Pump Overrun Fault Finding, see diagram 9.2, Fault Finding Wiring Diagram, see diagram 9.4, Pictorial Wiring Diagram, see diagram 9.5.

9.2 Electrical Supply Failure

Failure of the electrical supply will cause the burner to go out. Operation will normally resume on the restoration of the electrical supply.

If the burner does not relight after an electrical supply failure the overheat device may need resetting.

Open the control cover, see diagram 9.1 and if the RESET neon is lit, turn temperature control on the front of the control box to "0", and then back again, see diagram 9.1.

If the safety temperature limiter operates at any other time, do as above, the burner should relight. If the fault persists refer to fault finding chart.

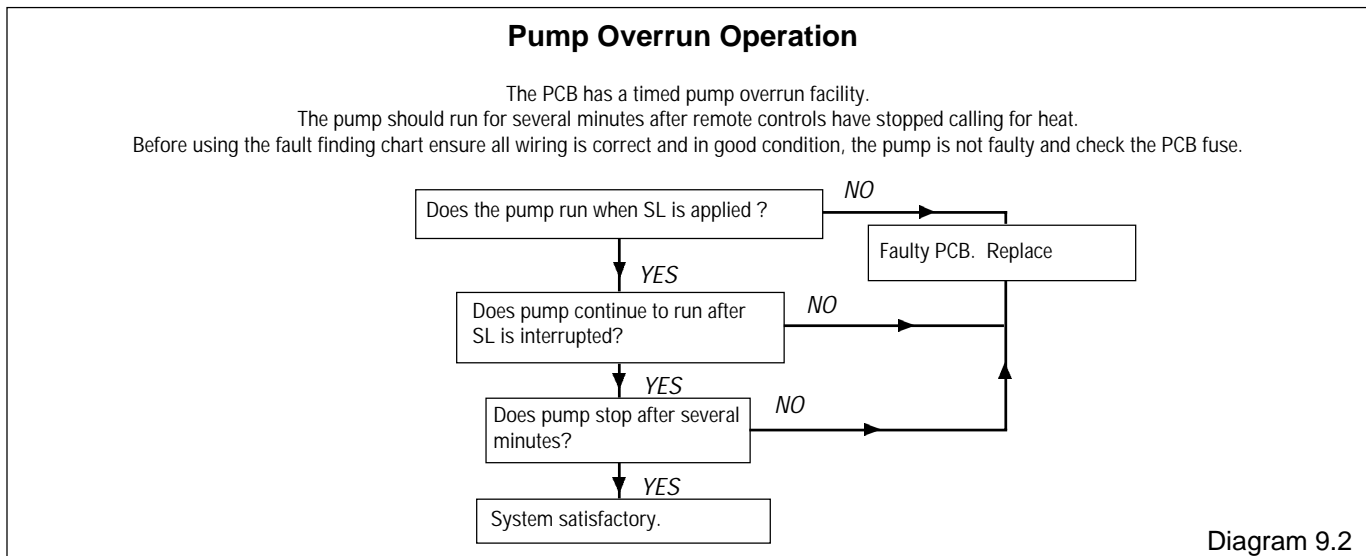
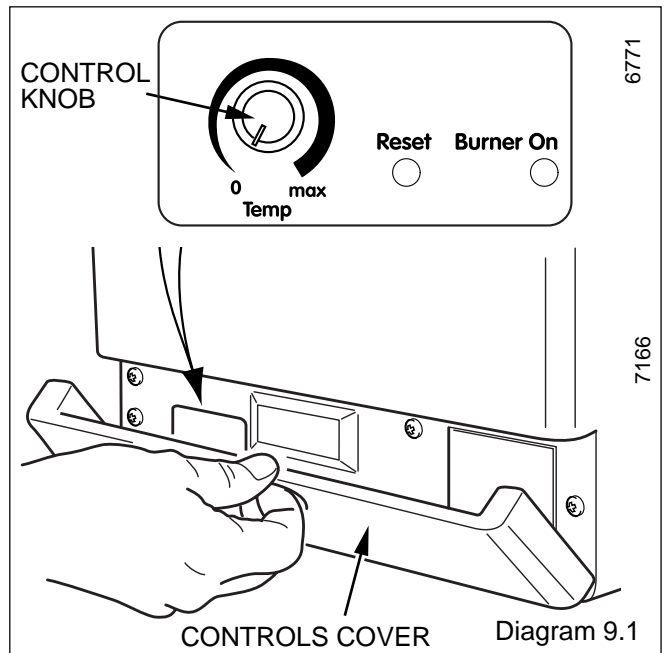

9 Fault Finding

10270

Before carrying out fault finding, ensure that gas, electricity and water are available to the boiler. Ensure that any external controls are calling for heat and circuit water is cold. If Reset LED is lit - check water system for overheating, reset by turning temperature control knob off and on. If the LED coding is showing an ignition failure, reset the boiler by turning the control knob off and on. Do not operate the boiler without combustion chamber front fitted.

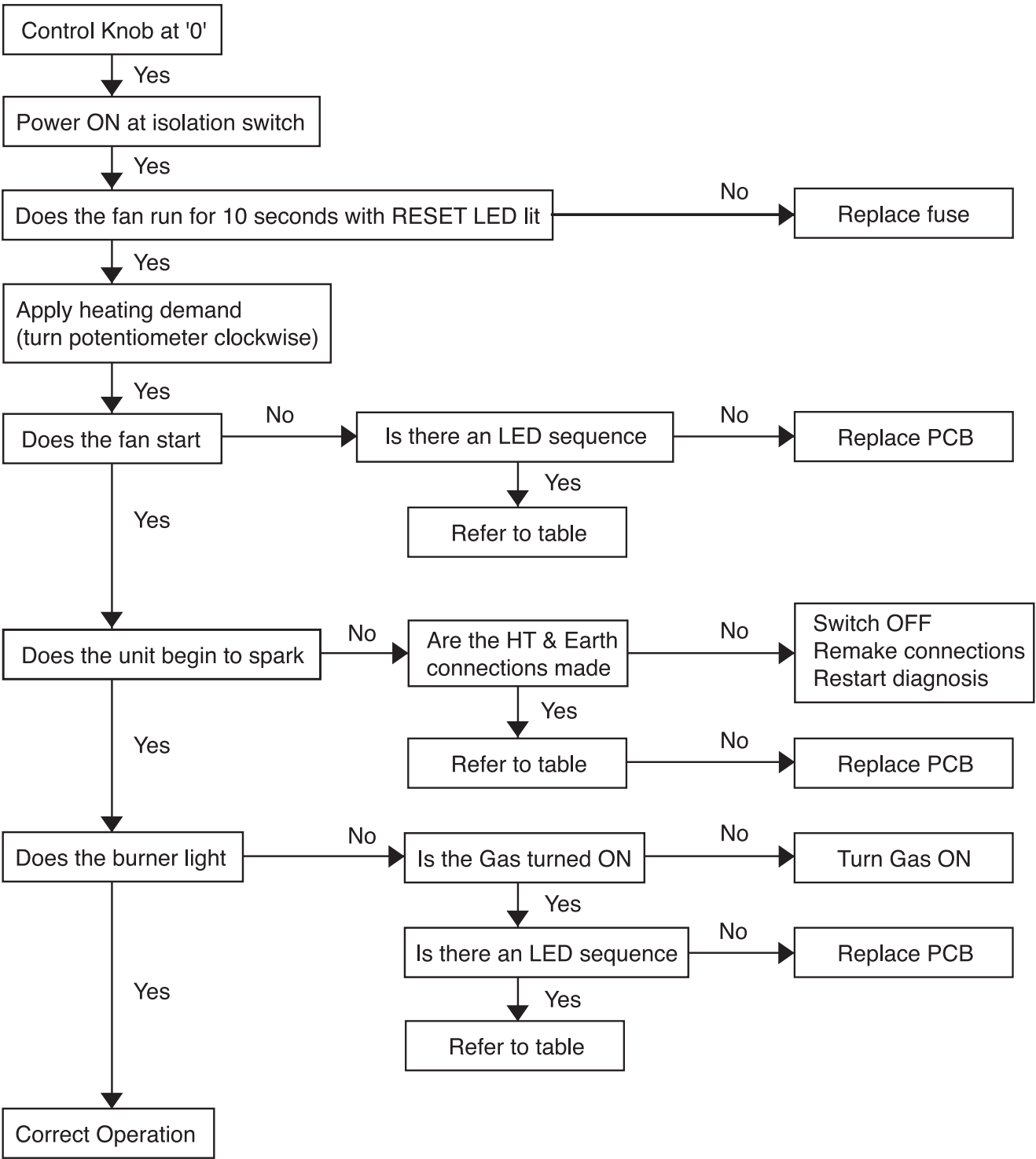

Diagram 9.3

9 Fault Finding

10275

LED Fault Coding

LED 1 (RESET)	LED 2 (BURNER LIT)	LED STATUS	CONDITION
●	○		Non - Volatile Lockout
○	●		Burner Lit
⊙	○		PCB Failure
⊙	○		Other Errors
⊙	⊙	Simultaneous	Reversed Polarity
⊙	⊙	Simultaneous	Lighting Sequence - Thermistor
⊙	⊙	Simultaneous	Lighting Sequence - Fan/APS
⊙	⊙	Alternating	Software Sequence Error
●	⊙		Software Error
●	⊙		Ignition Lockout

⊙ Slow Flashing (2Hz)

⊙ Fast Flashing (8Hz)

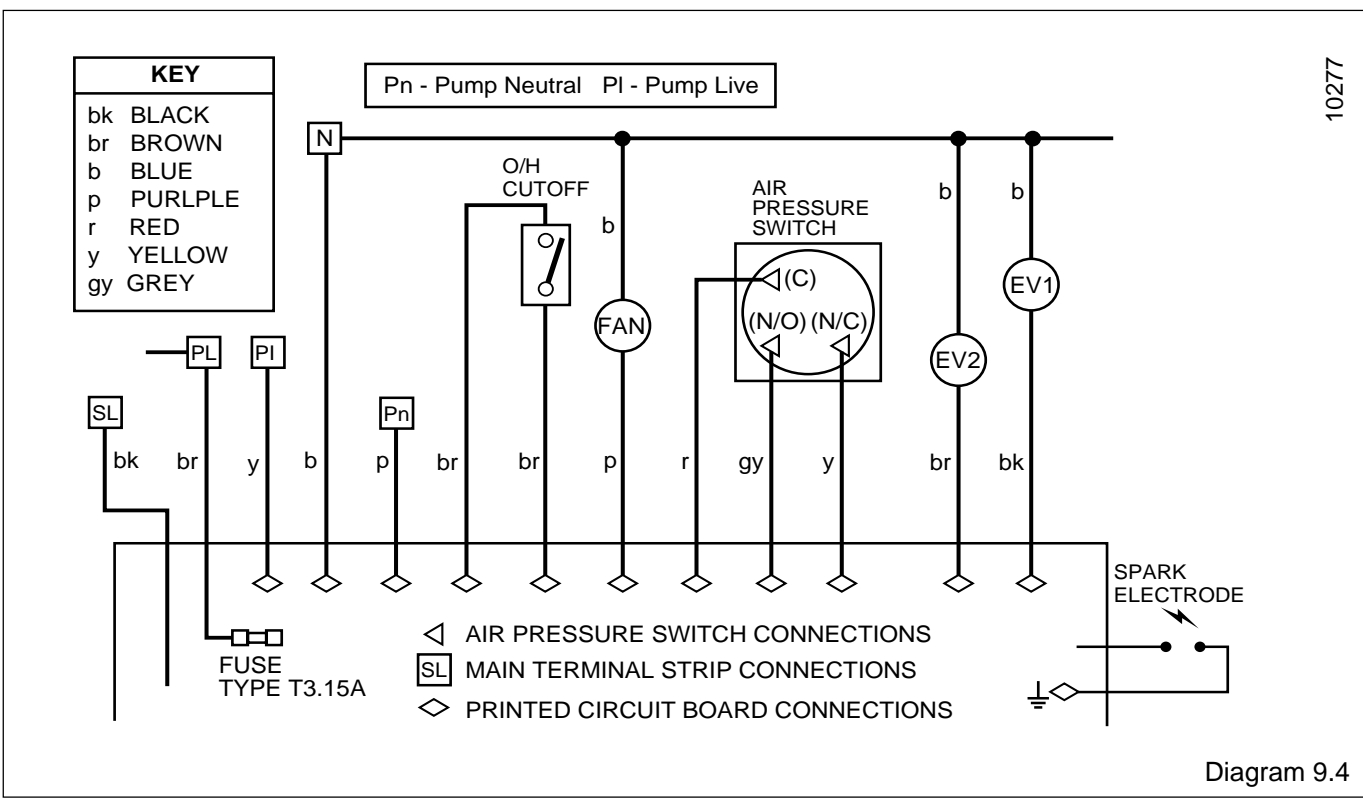
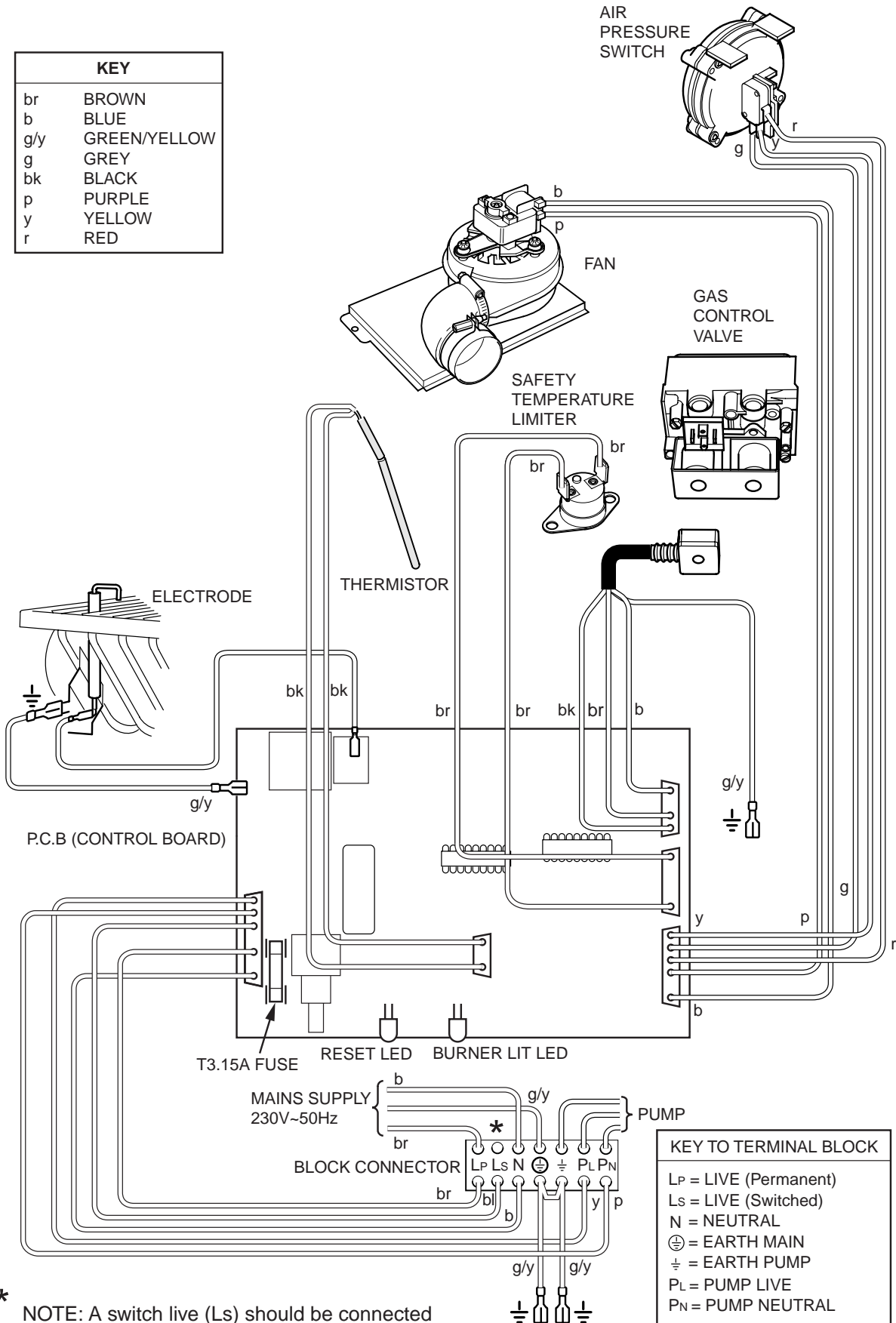

Diagram 9.4

9 Fault Finding

10274

KEY	
br	BROWN
b	BLUE
g/y	GREEN/YELLOW
g	GREY
bk	BLACK
p	PURPLE
y	YELLOW
r	RED



KEY TO TERMINAL BLOCK	
LP	LIVE (Permanent)
Ls	LIVE (Switched)
N	NEUTRAL
⊕	EARTH MAIN
⊕	EARTH PUMP
PL	PUMP LIVE
PN	PUMP NEUTRAL

* NOTE: A switch live (Ls) should be connected from an external control. If no external control is available insert a link between Lp & Ls.

Diagram 9.5

10 Replacement of Parts

Note. Replacement of parts must only be carried out by a competent person.

Before replacing any parts isolate the boiler from the electrical supply and turn the gas supply off at the gas service cock, see diagram 6.2.

Unless stated otherwise, all parts are replaced in the reverse order to removal.

After replacing any parts always test for gas soundness and if necessary carryout functional check of controls.

10.1 Access

Gain Access as Section 5.2.

10.2 Electrical Thermistor, Part No. 227036

Slacken control box securing screw and swing out the control box, see diagram 5.9.

Disconnect the thermistor plug from the control board by slightly bending the retaining latch and removing the plug, see diagram 10.1.

Remove fan assembly, see section 5.3.

Remove the plastic R clips which retain all leads at the rear of boiler.

Remove the retaining wire and withdraw the electrical thermistor from its phial, see diagram 10.2.

Remove thermistor lead from the plastic R clips at rear of case and the cable clips (these are located down left hand side of boiler).

Draw thermistor lead followed by thermistor out through the case grommet.

Re-assembly note. When fitting the thermistor make sure it is fully inserted into the phial, see diagram 10.2. Take care when re-threading as not to damage thermistor.

Refit the cable clips and the plastic R clips retaining the leads.

Refit the plastic retaining tag.

Refit the thermistor lead plug.

Refit fan assembly.

Important: Where the flue has a rear connection (from back of casing), see diagram 5.6, it is essential to make certain that the flue duct is fully located into the fan elbow until it can go no further, enabling the flue duct to make a complete seal when secured.

10.3 Safety Temperature Limiter, Part No. 227038 - diagram 10.2

Gain Access as Section 5.2.

Remove air pressure switch, see diagram 10.6.

Remove the electrical connections from the safety temperature limiter device, see diagram 10.2.

Undo retaining bracket screw and remove together with safety temperature limiter.

When refitting use the heat sink compound provided

Re-assembly note. Check that safety temperature limiter is secure.

Note: Polarity of electrical connections is not important.

10.4 Control Board (PCB), Part No. 2000227135 - diagram 10.3

Remove casing, see Section 5.2.

Slacken control box securing screw, see diagram 5.10.

Note: To ease access the control box may be pulled away from the boiler by removing the hinge pins, see diagram 5.10.

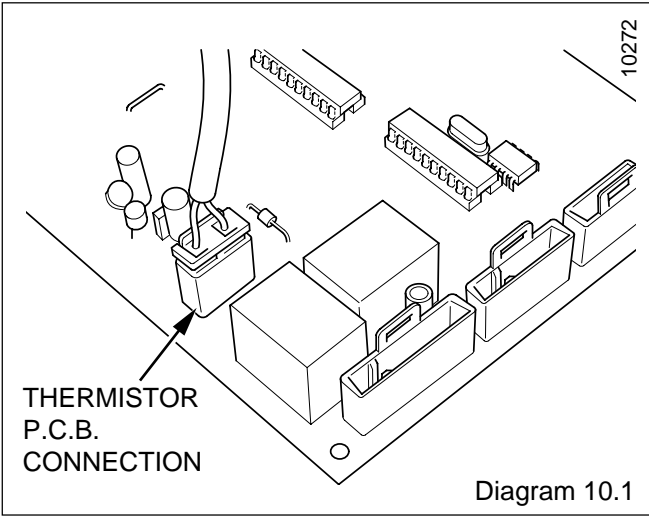

Diagram 10.1

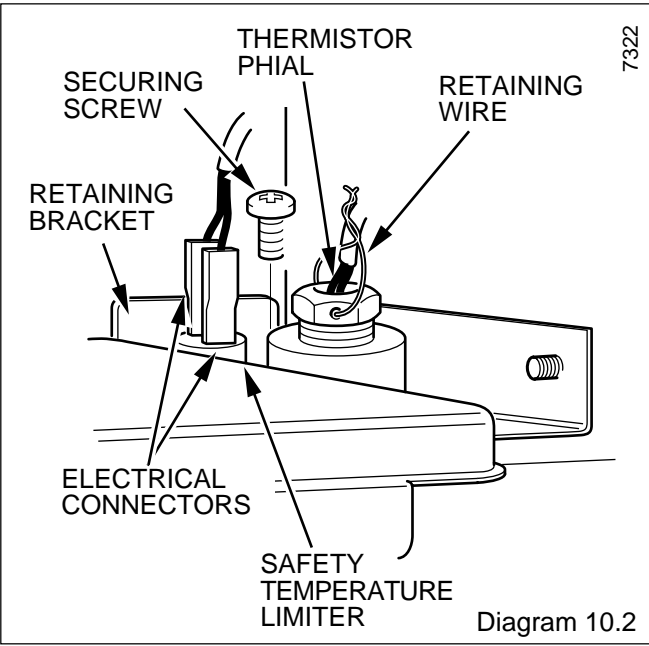

Diagram 10.2

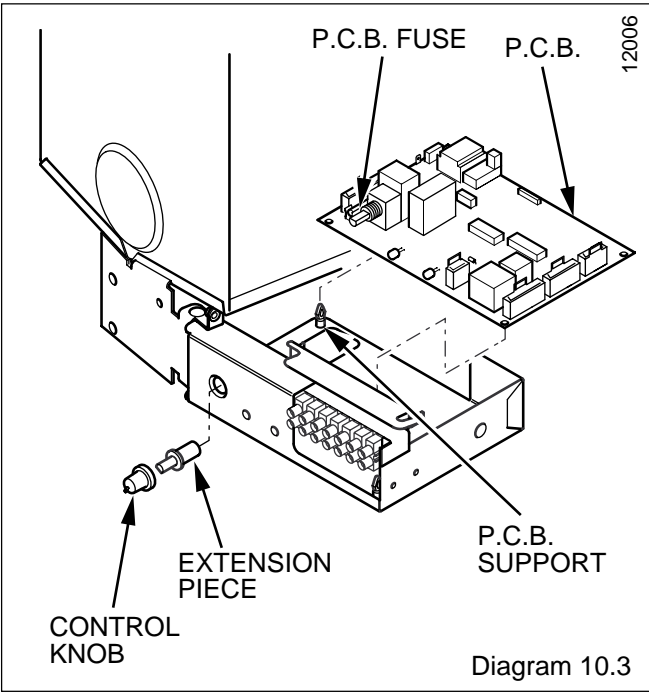

Diagram 10.3

10 Replacement of Parts

Carefully pull the control knob and extension piece away from the PCB.
 Carefully pull the board away from its supports.
 Disconnect the electrical plugs by slightly bending back the retaining latches to allow withdrawal.
 Disconnect the HT lead and spark earth lead.
 When refitting refer to wiring diagram 9.5.
 Take care when replacing the control knob and extension by supporting the potentiometer on the P.C.B.

10.5 Electrode, Part No. 202636

Remove casing, see Section 5.2.
 Remove combustion chamber front cover, see diagram 10.5
 Remove HT lead from electrode, see diagram 8.5.
 Remove earth lead from electrode retaining bracket, see diagram 8.5.
 Undo retaining bracket securing screw and withdraw bracket, see diagram 8.5.
 Undo electrode securing screw and withdraw electrode.
 When refitting, check spark gap, see diagram 8.5.

10.6 Multifunctional Control, Part No. 230509 - diagram 10.4

Gain access as Section 5.2.
 Slacken control box securing screw, and swing out the control box, see diagram 5.10.
 Disconnect the electrical plug.
 Disconnect from the gas cock by removing the four extended screws from the flanged connection at the right hand side.
 Support the multifunctional control, disconnect from the manifold by removing the tubing nut from the left hand side.
 Remove and discard the original "O" ring from the flanged connection and fit the new "O" ring supplied, into recess, before fitting the replacement multifunctional control.
 After assembly test for gas soundness and purge in accordance with the current issue of BS6891 or in IE, the current edition of I.S.813 "Domestic Gas Installations".

10.7 Solenoid - diagram 10.4

Remove the electrical plug from the multifunctional control.
 Remove the securing screw and then the solenoid assembly.

10.8 Burner

Remove the burner as Section 8.2.

10.9 Injectors, Part No. 205764

Remove the burner as Section 8.2.
 Remove the injectors as Section 8.4.

10.10 Insulation - diagram 10.5

Combustion Chamber Front

Gain Access as Section 5.2.
 Remove the combustion chamber front, then the insulation.

Sides

Slide the insulation out.

Rear

With the side insulation removed the rear insulation can be removed and replaced.

10.11 Air Pressure Switch, Part No. 227128 - diagram 10.6

Gain Access as Section 5.2.
 Remove the air pressure tubes and electrical connections from the switch, release the screw and remove the switch.
 When fitting the replacement make sure that the plastic tubes are fitted as shown in diagram 10.6 and the electrical connections as shown in diagram 9.5

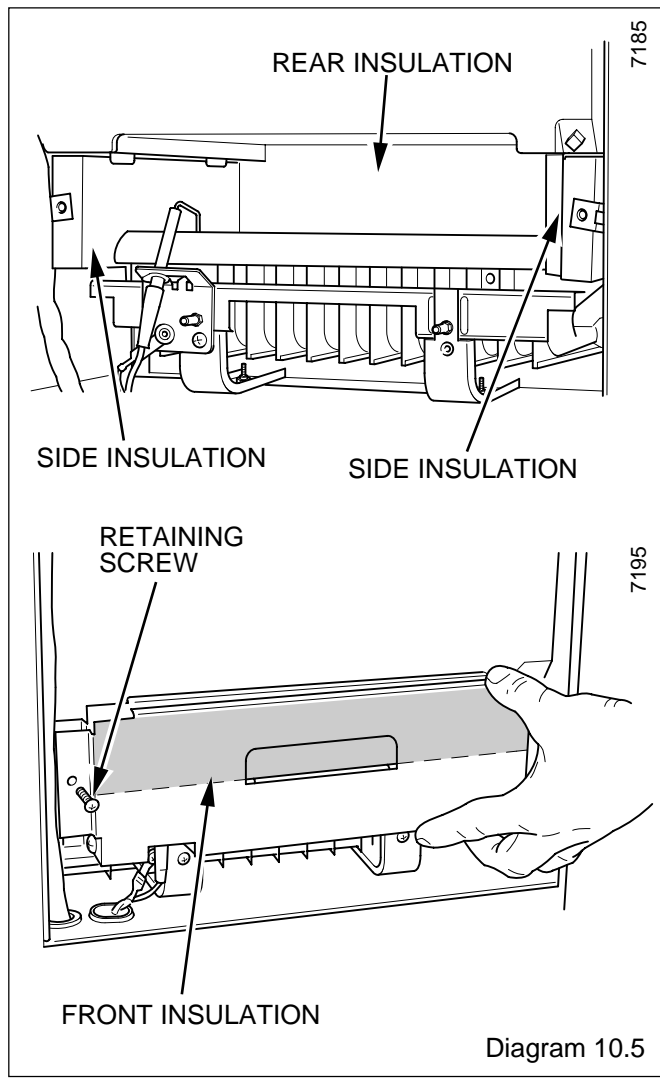
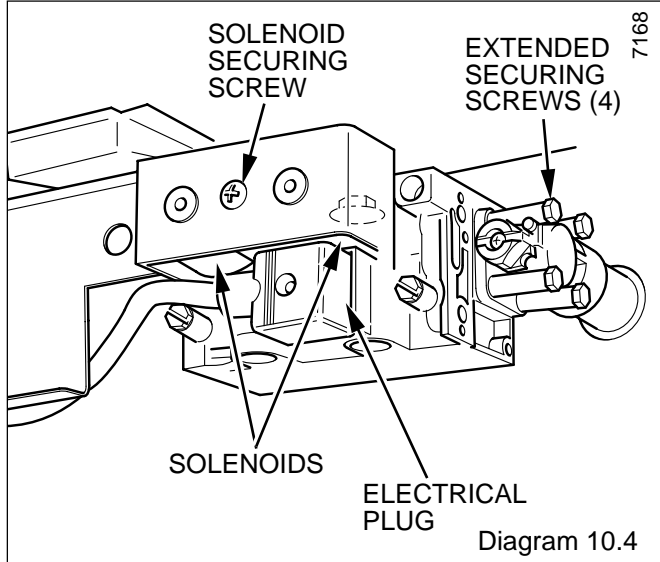

10 Replacement of Parts

10.12 Fan, Part No. 227035 - diagram 10.7

Refer to Section 5.3.

Remove the electrical connections and disconnect the air tubes.

Note: Remove the electrical connections by pulling insulation boots only.

Remove the fan assembly securing screw at the front, then withdraw the assembly.

The fan is secured to the flue hood by three screws.

The polarity of the electrical connections are not important.

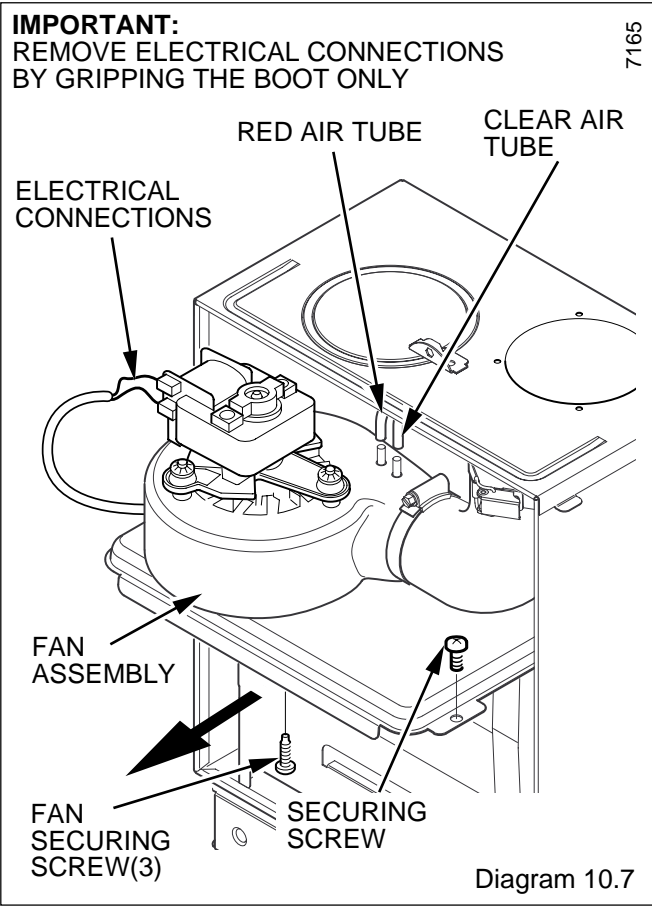
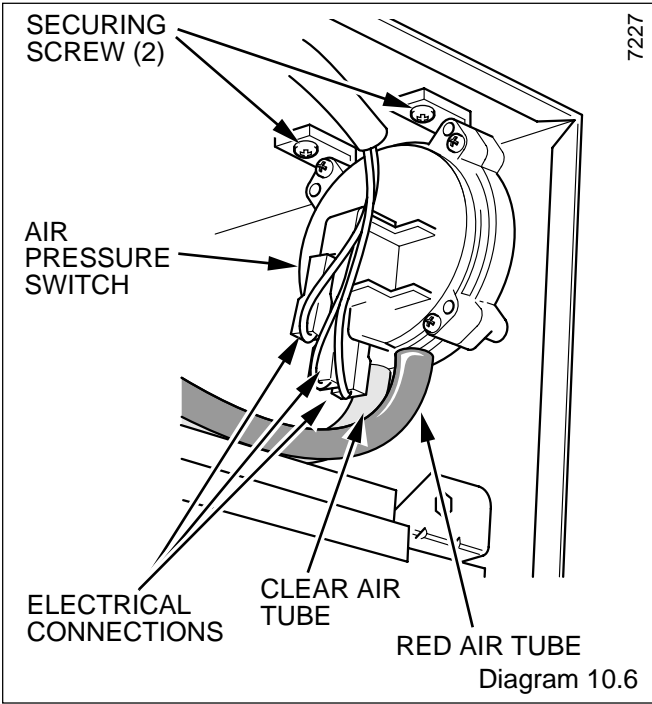

11 Spare Parts

11.1 Part Identification

The part number on the diagram location will help to identify the part.

11.2 Ordering

When ordering any spare parts please quote the number and description from the list together with the model name and serial number.

If ordering from the local gas undertaking also quote the GC number of the appliance.

Part No	Description	Location	GC Part No
801136	Multifunctional control	Diagram 10.4	E24965
227035	Fan	Diagram 10.7	E24976
227128	Air pressure switch	Diagram 10.6	*****
227036	Electrical thermistor	Diagram 10.1 & 10.2	E24967
202636	Spark electrode	Diagram 8.5	E24957
204697	Control knob	Diagram 10.3	E24870
205764	Injector	Diagram 8.4	*****
227098	Fuse	Diagram 10.3	*****
2000227135	Control board	Diagram 10.3	*****
227038	Safety temperature limiter	Diagram 10.2	E24897

Because of our constant endeavour for improvement, details may vary slightly from those shown in these instructions.