

Calydra comfort

COMBINATION BOILER

Heating and Instantaneous Domestic Hot Water with TSS®

Fanned Flue system

Installation and Operating instructions

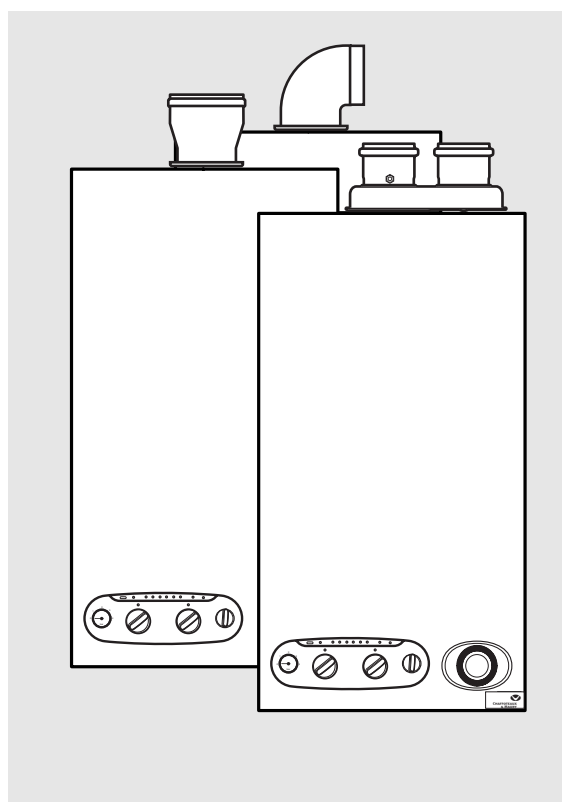

Calydra comfort 80
Calydra comfort 100

Manufactures N°

200906789037.31

200906790037.31

Model Type

Calydra comfort 80 Nat

Calydra comfort 100 Nat

Gas Council N°

47 - 980 - 22

47 - 980 - 23



**CHAFFOTEAUX
& MAURY**

These instructions are suitable for the following boilers :

Calydra comfort 80

Calydra comfort 100

Do not forget the Logbook!

Chaffoteaux & Maury supports Benchmark, the heating industry code to ensure the correct installation, commissioning and servicing of domestic central heating systems.

To The Householder

Make sure you have a completed Logbook for your boiler. This provides a record of the commissioning of your boiler. It contains important information about your particular installation that may be required by service engineers. The logbook will also provide contact details for the installer should you need guidance in the use of this appliance or if there are any problems.

As with your car, your boiler will work more reliably and efficiently if regularly serviced. We recommend an annual service check. The service history of the appliance will be recorded on the logbook.

In the unlikely event of any problems with your boiler or system you should first contact your installer. If your installer cannot resolve the problem he should telephone our national service helpline.

A charge may be made if Chaffoteaux & Maury Service is called out to resolve a non-product related fault.

Your statutory rights are not affected.

TO CONTACT C&M SERVICE, PLEASE CALL THE NATIONAL WARRANTY HELPLINE ON:

0 870 243 0224

To The Installer

As part of the commissioning of this appliance it is vital that the Logbook is completed and given to the Householder. Please ensure that your customer is aware of the importance of keeping the Logbook safe as a record of the installation and the appliance service history.

Please ensure that your customer is aware of the correct operation of the system, boiler and controls.

CUSTOMER CARE

Chaffoteaux & Maury Ltd., as a leading manufacturer of domestic and commercial water heating appliances is committed to providing high quality products and a high quality after sales service. If it is necessary to contact an engineer, then telephone the national warranty helpline 0870 243 0224.

Advice on installation or servicing can also be obtained by contacting the Chaffoteaux Customer Services Department at Telford.

CUSTOMER SERVICES DEPARTMENT

Tel: 01952 222288

Fax: 01952 260915

GUARANTEE

The manufacturer's guarantee is for 12 months from the date of purchase. The guarantee is invalidated if the appliance is not installed in accordance with the recommendations made herein or in a manner not approved by the manufacturer. To assist us in providing you with an efficient after sales service, please return the guarantee registration card enclosed with the boiler without delay.

STATUTORY REQUIREMENTS

The installation of this appliance must be carried out by a CORGI Registered person or other competent person and in accordance with the requirements of the Gas Safety (Installation and Use) Regulations.

In addition, the installation must also comply with the current byelaws of Local Water Undertakings, Building Regulations, IEE Wiring Regulations, Local Authority Building Standards (Scotland) Regulations and the Safety Document 635 The Electricity at work Regulation. The appliance named below does not contain any asbestos or asbestos products, or mercury derivatives. Additional CFC's have not been used in this product.

The appliance does not contain any potential hazard in relation to the COSHH regulations.

It should also be carried out in accordance with current editions of the following British Standards Codes of practice: BS 6891, BS 5440 parts 1 and 2, BS 5449 part 1, BS 7593, BS 6798, BS 5546, BS 4814, BS 7074 part 1 and 2, BS 7671 and BG DM2.

If there is a possibility of the incoming mains water pressure exceeding 10 bar then a suitable pressure limiting valve must be fitted where pressures exceed 6 bars a pressure limiting is preferred.

Precautions: During servicing, keep the dust generation to a minimum and avoid inhaling any dust and contact with the skin and eyes. Normal handling and use will not present any discomfort, although some people with a history of skin complaints may be susceptible to irritation. When disposing of the ceramic lining, ensure that it is securely wrapped and wash hands after contact.

Contents

	Page		Page
CUSTOMER CARE.....	2	System Controls	11
Guarantee	2	Bypass and pump	11
Statutory Requirements	2	Expansion Vessel	11
Contents.....	3	Filling Point.....	11
INTRODUCTION.....	3	COMMISSIONING AND TESTING	12
DESCRIPTION.....	4	Pre-commissioning	12
Location of components	4	Domestic Hot Water	12
TECHNICAL DATA	5	Central Heating.....	12
DIMENSIONS	6	Lighting the boiler	12
OPERATION	7	Post Commissioning.....	12
Domestic Hot Water Mode	7	Handing over to the Householder.....	12
Central Heating Mode	7	USER'S INSTRUCTIONS	13
INSTALLATION REQUIREMENTS.....	8	Control panel	13
Location.....	8	Isolating taps	13
Flue	8	Switching on	13
Ventilation	8	Hot water	13
Gas Supply.....	8	Heating	13
Electrical Supply.....	8	Turn off the boiler	13
INSTALLING THE BOILER.....	9	INSTRUCTION FOR SETTING THE BUILT IN CLOCK.....	14
Installation	9	INCORRECT FUNCTION.....	15
Fitting the horizontal flue	9		
Making the electrical connections	10		
SYSTEM GUIDANCE	11		
Showers	11		
Flushing and Water Treatment.....	11		

1

Introduction

By combining their modern highly efficient low water content fanned flue combination boiler concept and the brand new TSS® "Temperature Stabilised System", Chaffoteaux et Maury have created a whole new concept.

Calydra comfort

This unique combination is able to provide the user with hot water immediately at the outlet of the appliance and stable temperatures at both extremely low flow rates or when several taps are opened together.

The TSS® is a 5 litres, independently controlled mini unvented storage cylinder, powered by a 3 kW coil. It works in conjunction with the Chaffoteaux et Maury low pressure instantaneous domestic hot water system.

The Calydra comfort, as well as providing hot water, provides central heating. The boiler is designed for sealed systems only. A one speed circulating pump, diverter valve, expansion vessel as well as a pressure gauge and safety valve are included within the boiler.

The Calydra comfort provides the advantages of mains pressure hot water to taps and showers. Supplied directly from the main water supply the Calydra comfort does not need a separate feed cistern or vent pipe in the loft space.

The Calydra comfort has been tested and approved by the WRc as meeting with the requirements of the water by-laws scheme.

The boiler has been tested and approved to carry the CE mark.

The Calydra comfort can be installed with the standard horizontal flue, raised horizontal, concentric vertical, twin pipe flue or seduct arrangements. Adapters, bends and other accessories are available on request.

The boiler is packed in TWO cartons:

1. The boiler.
2. The flue assembly and fixing kit.

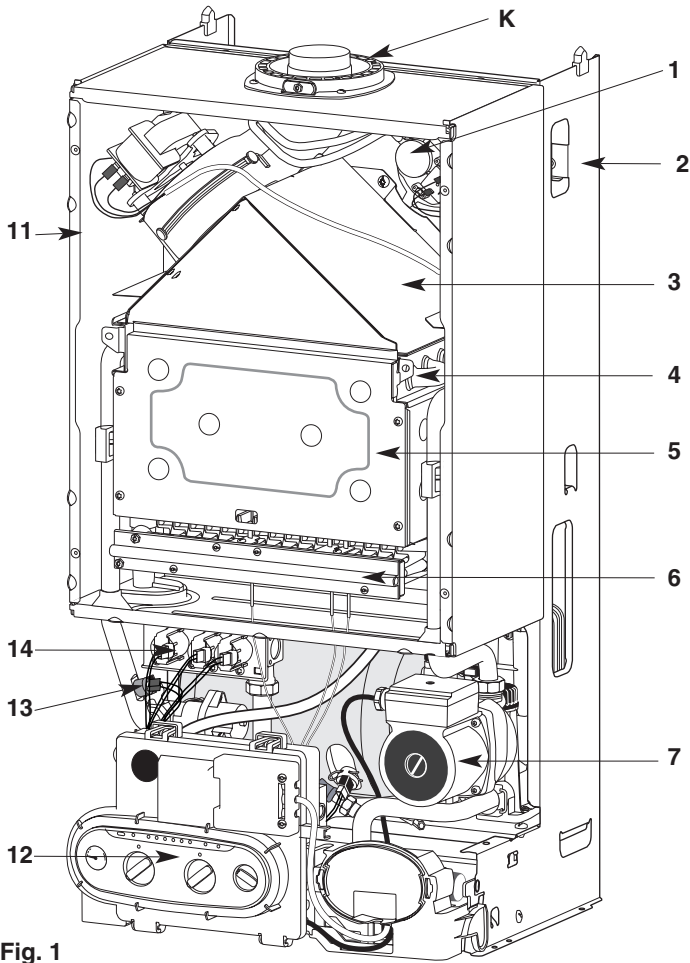

Fig. 1

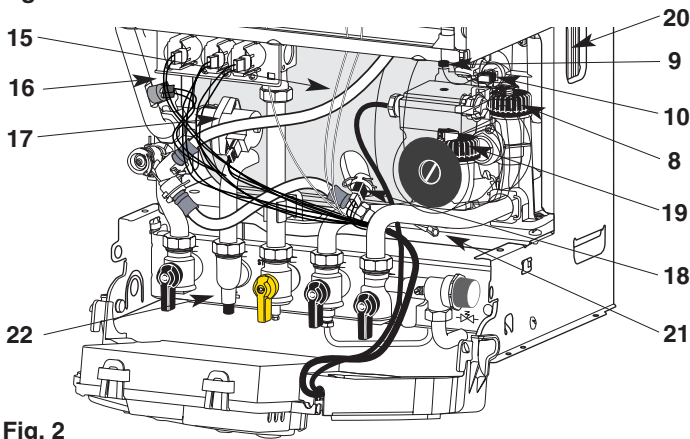

Fig. 2

Location of components

- 1. - Air pressure switch
- 2. - Steel chassis complete with expansion vessel
- 3. - Flue hood with fan
- 4. - Main heat exchanger
- 5. - Combustion chamber
- 6. - Multi- gas burner assembly comprising ignition and ionisation electrodes
- 7. - Pump
- 8. - Central heating eating flowswitch
- 9. - Automatic air separator and automatic vent
- 10. - DHW detector
- 11. - Sealed chamber
- 12. - Electrical box
- 13. - Overheat safety cutout
- 14. - Gas valve assembly
- 15. - TSS® (mini cylinder)
- 16. - Central heating control thermistor
- 17. - Three way valve
- 18. - TSS® control thermistor
- 19. - Domestic hot water flowswitch
- 20. - Secondary heat exchanger
- 21. - DHW pressure relief valve
- 22. - Taps bracket
- 23. - Two position Selector switch
OFF «O»
ON «I»
- 24. - Domestic hot water temperature adjustment
- 25. - Heating flow temperature control knob
- 26. - Heating temperature indicator lights
- 27. - Green indicator - Power ON
- 28. - Orange indicator - Burner ON
- 29. - Red indicator - Lock out / flame failure
- 30. - Reset button
- 31. - Pressure gauge
- 32. - DHW mode indicator
- 33. - Heating mode indicator
- K. - flue kit fixing point (refer to kit manual)

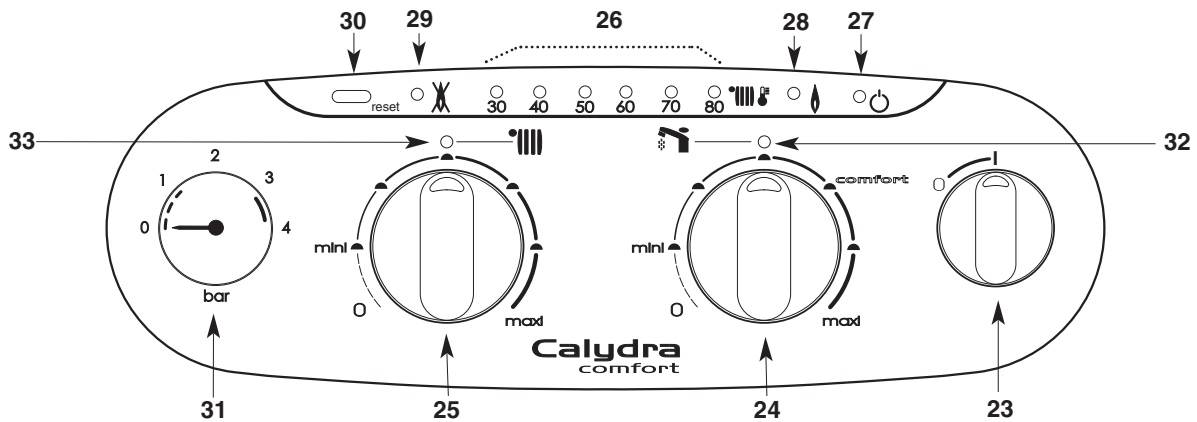

Fig.3

Calydra comfort	80	100	Calydra comfort	80	100
Appliance category	Cat II _{2H 3+}	Cat Ii _{2H 3+}	PROPANE L.P.G. G31		
Heat Gross input C/H & DHW			Gas rate		
Maximum in kW	28.7	34,6	Maximum in kg/h	2.00	2.42
Maximum in Btu/h	98000	117900	Maximum in ft ³ /h	37	44,8
Heat output C/H & DHW			Inlet pressure		
Maximum in kW	24	28	Nominal in mbar	37	37
Maximum in Btu/h	81910	95600	Nominal in in wg	14.8	14.8
C/H operating temperature			Burner pressure		
Max:	85° C	85° C	Nominal in mbar	35	30.4
Mini:	35° C	35° C	Nominal in in wg	14	12.2
C/H circuit pressures			BUTANE L.P.G. G30		
Min operating in bar	0.7	0.7	Gas rate		
in lb/in ²	10	10	Maximum in kg/h	2.04	2.45
Max operating in bar	2.5	2.5	Maximum in Lbs/h	4.50	5.40
in lb/in ²	36.3	36.3	Inlet pressure		
DHW flow rates			Nominal in mbar	28	28
@ AT 30 K in l/min	11.9	13.9	Nominal in in wg	11.2	11.2
in gal/min	2.62	3.06	Burner pressure		
@ AT 35 K in l/min	10.02	11.9	Nominal in mbar	26,7	24
in gal/min	2.24	2.62	Nominal in in wg	10.7	9.6
Cold water mains pressures			Burner injector diameter		
Min operating in bar	0.5	0.5	LPG G30 and G31 in mm	0.70	0.76
in lb/in ²	7.25	7.25	Safety discharge		
Max operating in bar	10	10	in bar	3	3
in lb/in ²	145	145	in lb/in ²	43.5	43.5
Flow limiter rate in l/min	8	10	Expansion vessel		
Compartment ventilation	n o t r e q u i r e d				
Natural gas G20			Pre-charge pressure in bar		
Gas rate			Pre-charge pressure in lb/in ²	10	10
Maximum in m ³ /h	2.74	3.29	Net capacity at 3 bar in liter	6	6
Maximum in ft ³ /h	97	116	Automatic by-pass		
Inlet pressure			Electrical characteristics		
Nominal in mbar	20	20	Supply	230 v	230 v
Nominal in in wg	8	8	Consumption	150 w	150 w
Burner pressure			Protection	IP 44	IP 44
Nominal in mbar	11	12.8	Fuse n°1	2 A	2 A
Nominal in in wg	4.4	5.1	Fuse n°2	1.25 A	1.25 A
Burner injector diameter			External controls	24 v	24 v
Natural gas G20 in mm	1.23	1.28			

Outer case dimensions :
 - Width : 440 (minimum space required 450)
 - Height : 850
 - Depth : 380

All dimensions in mm

Minimum clearances :

- Both sides 5 mm
- Above casing 170 mm
- Below casing 200 mm
- Front (for servicing) 500 mm
- Front (in operation) 5 mm

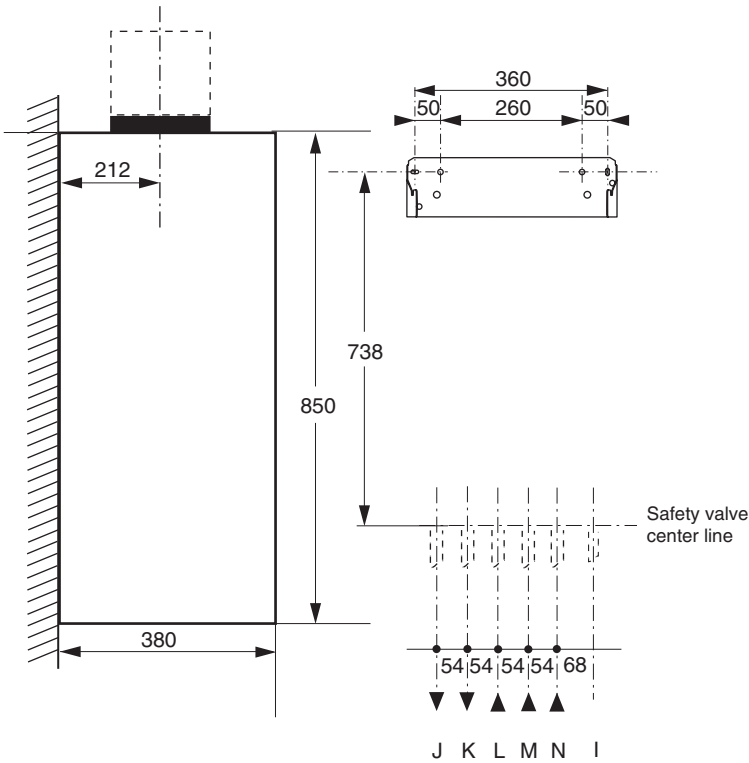

The boiler is suitable for the 3 flue types:

- Type C 12 or C 42
- Type C 22
- Type 32 xx
- Type C 32 xy

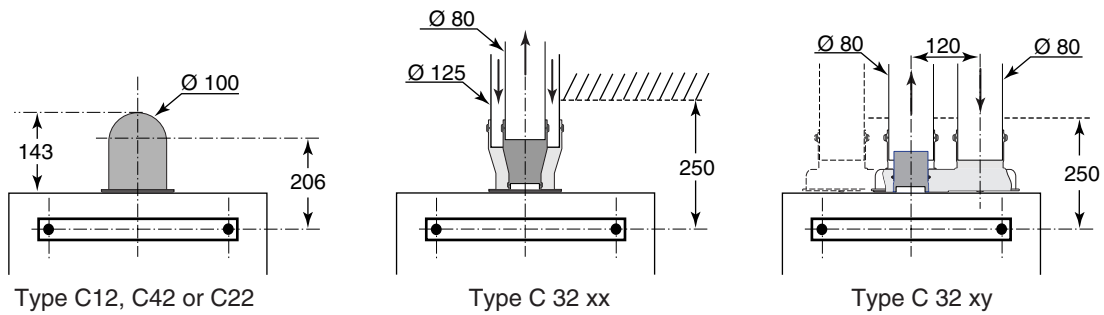

Fig. 4

Weights

With packaging :

- Calydra comfort 80 : 39,5kg
- Calydra comfort 100 : 40,5kg

Without packaging :

- Calydra comfort 80 : 37,5kg
- Calydra comfort 100 : 38,5kg

Lift weight :

- Calydra comfort 80 : 31,5 kg
- Calydra comfort 100 : 32,5kg

Tails diameter

- | | | |
|---|---------------------|---------|
| I | Safety valve outlet | Ø 15 mm |
| J | Heating flow | Ø 22 mm |
| K | D.H.W. flow | Ø 15 mm |
| L | Gas supply | Ø 22 mm |
| M | Cold water inlet | Ø 15 mm |
| N | Heating return | Ø 22 mm |

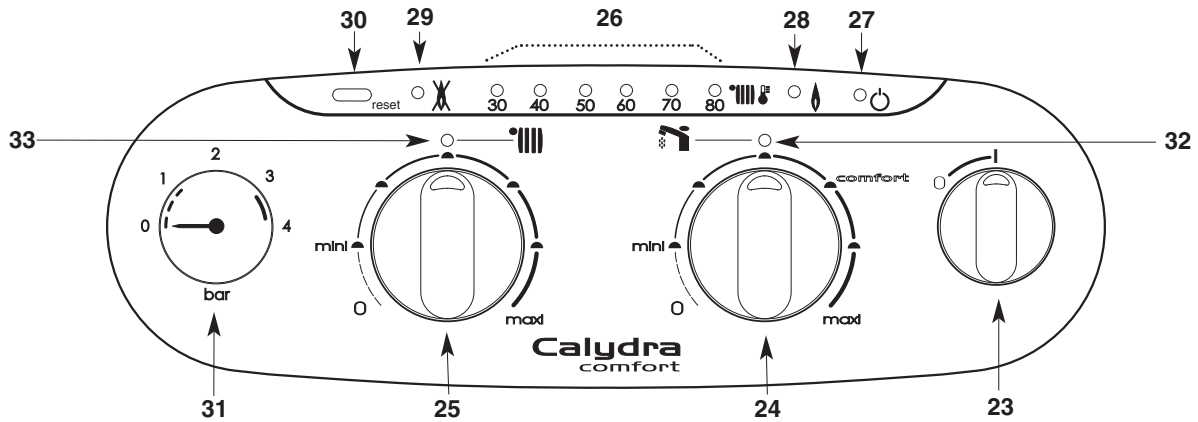

Fig.5

Domestic Hot Water Mode

In order to supply hot water, the main switch **23** (fig. 5) must be in ON position **I**. This will be confirmed by the green indicator light **27** (fig. 5). Turn DHW temperature adjustment knob **24** clock wise to establish the green DHW indicator **32** (fig. 5).

The hot water temperature in the mini cylinder can be adjusted between 40 and 60°C using control knob **24** (fig 5).

When a tap or shower is turned on, the flow of mains water, above 2 litres per min., will activate the 3 way valve **17** (fig. 2) to move to the DHW position. The pump will now circulate primary water heated by the main heat exchanger through the secondary heat exchanger.

The first stage solenoid **a** (fig. 6) and safety solenoid **c** (fig. 6) open together to allow gas to the burner. The ignition sequence begins and a continuous high speed spark ignites the gas. As soon as a flame is detected the orange indicator bulb **28** (fig. 5) will light and the second stage solenoid **b** (fig. 6) opens to allow the full gas rate. If a flame is not detected, after 8 seconds, the security solenoid closes and shuts off the gas. The red lockout indicator bulb **29** (fig. 5) will show. Over 2 l/min, the domestic hot water temperature

is controlled by the hot water control thermistor **d** (fig. 6) and the heating control thermistor **e** (fig. 6), but dependant upon to the position of the DHW temperature adjustment knob **24** (fig. 5). This system anticipates the changes of temperature in the secondary heat exchanger and ensures accurate temperature regulation.

When the tap is closed the burner is extinguished and the pump stops. (unless the mini cylinder thermistor is calling for heat, in which case the burner will remain on at a low rate and the pump will continue running until the mini cylinder thermistor is satisfied). The boiler will now stay in the hot water mode for 30 seconds to be ready for a subsequent draw off

Priority is given to a demand for hot water. This will interrupt the central heating for the duration of hot water delivery or recovery of the mini cylinder.

When the boiler has been in standby in Hot Water Mode for some time or when drawing DHW at flow rates of less than 2 l/min the temperature in the mini cylinder will eventually decrease and the TSS® control thermistor **f** (fig. 6) will call for heat. Bringing the pump and burners to operate, until the cylinder thermistor is satisfied. this is quite normal.

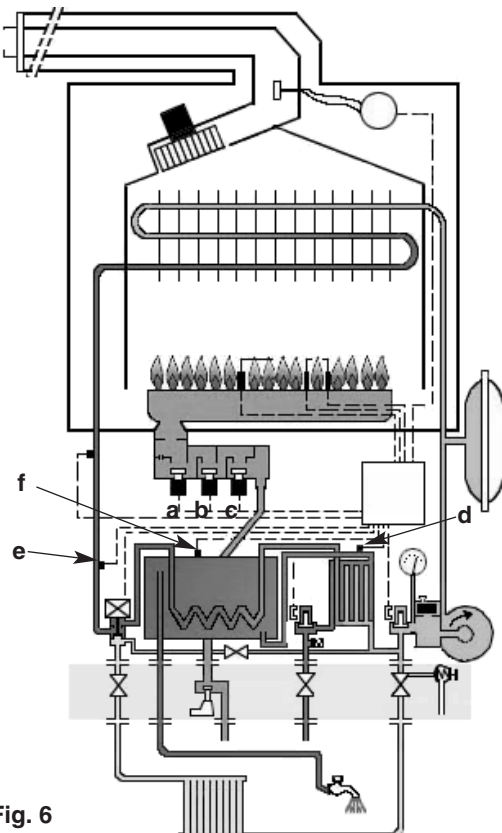

Fig. 6

Central Heating Mode

To be able to supply heating, the main switch **23** (fig. 5) must be in **I** position. This will be confirmed by the green indicator light **27** (fig. 5.) Turn the temperature control knob **25** clock wise to establish the green heating indicator **33** (fig. 5).

When there is a demand for heating (either from the room thermostat or the clock) and the boiler temperature control is calling for heat. The pump starts allowing the ignition sequence to begin. The first stage solenoid **a** (fig. 6) and safety solenoid **c** (fig. 6) open together to allow gas to the burner. The ignition sequence begins and a continuous high speed spark ignites the gas. As soon as a flame is detected the orange indicator bulb **28** (fig. 5) will light. After 45 seconds the second stage solenoid **b** (fig. 6) opens to allow the full gas rate. If a flame is not detected, after 8 seconds, the security solenoid closes and shuts off the gas. The red lockout indicator bulb **29** (fig. 5) will show.

The central heating flow temperature is controlled by the central heating control thermistor **e** (fig. 6). The boiler has been designed to minimise cycling and will not attempt to relight for at least 3 minutes after the boiler thermostat has been satisfied (it is possible to reduce the time to 30 s if necessary). When the room thermostat is satisfied the burner will switch off and the pump will remain running for a further 4 minutes before it to stops.

NB : It is possible to override the 3 minute delay by pressing the RESET button **30** (fig. 5).

Location

The boiler can be installed on any suitable internal wall. Provision must be made to allow the correct routing of the flue and siting of the terminal to allow the safe and efficient removal of the flue products. A compartment or cupboard may be used provided that it has been purpose-built or modified for the purpose. It is not necessary to provide permanent ventilation for cooling purposes. Detailed recommendations are given in BS 5440 pt 2. If it is proposed that it is installed in a timber framed building then reference must be made to British Gas Document DM2, or advice sought from CORGI.

Flue

Detailed information on flue assembly is contained in the appropriate starter pack.

The boiler must be installed so that the flue terminal is exposed to the free passage of external air at all times. It must not be allowed to discharge into another room or space such as an outhouse or closed lean-to. The minimum acceptable clearances are shown below:

- A Directly below an opening, window, etc	300 mm
- B Above an opening, window, etc	300 mm
- C Horizontally to an opening, window, etc	300 mm
- D Below gutters, soils pipes or drain pipes	75 mm
- E Below eaves	200 mm
- F Below balconies or car port roof	200 mm
- G From a vertical drain pipe or soil pipe	150 mm
- H From an internal or external corner	300 mm
- I Above ground roof or balcony level	300 mm
- J From a surface facing the terminal	600 mm
- K From a terminal facing the terminal	1200 mm
- L From an opening in the car port into the dwelling	1200 mm
- M Vertically from a terminal on the same wall	1500 mm
- N Horizontally from a terminal on the same wall	300 mm
- Q Fixed by Ubbink Rolux 4 GM flue terminal	

It may be necessary to protect the terminal with a guard. Reference should be made to the Building Regulations for guidance. Suitable guards may be obtained from the following manufacturer:

Quinnel Barret & Quinnel Wireworks
Old Kent Road
London SE15 1NL
Tel: 0171 639 1357

Ventilation

The room in which the boiler is installed does not require specific ventilation. **If it is installed in a cupboard or compartment permanent ventilation is not required for cooling purposes.**

Gas Supply

The gas installation and soundness testing must be in accordance with the requirements of BS 6891. The boiler requires a 22 mm supply. Ensure that the pipe size is adequate for demand including other gas appliances on the same supply.

Electrical Supply

The appliance requires an earthed 230V - 50 Hz supply and must be in accordance with current I.E.E. It must also be possible to be able to completely isolate the appliance electrically. Connection should be via a 3 amp fused double-pole isolating switch with contact separation of at least 3 mm on both poles. Alternatively, a fused 3 Amp. 3 pin plug and unswitched socket may be used, provided it is not used in a room containing a bath or shower. It should only supply the appliance.

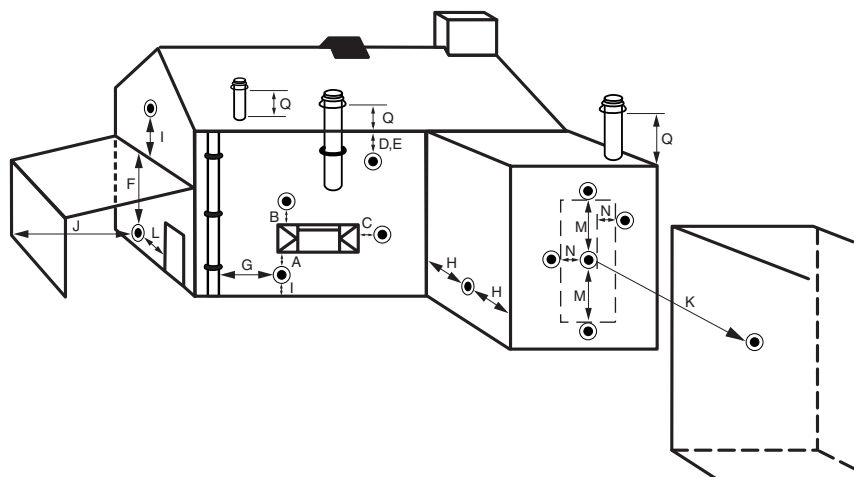

Fig. 7

7

Installing the boiler

Please check that you are familiar with the installation requirements before commencing work. (section 6)

Method of positioning the boiler on the wall.

The paper template can be used to ensure the correct positioning of kitchen cabinets etc. It also details the commissioning instructions.

The paper template has to be fixed to the wall and used to locate the position of the hanging bracket and the centre for the flue hole..

Drill and plug the wall and secure the hanging bracket using the screws provided. Remove the boiler from its packaging as shown in fig. 9 and remove the outer case as shown in fig.10.

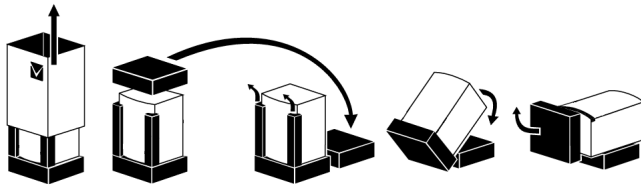

Fig. 8

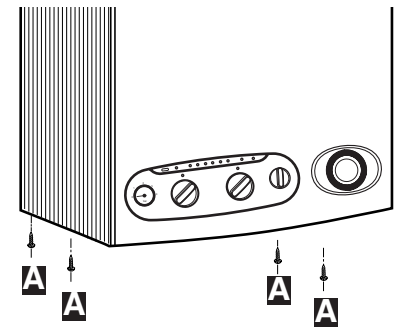

Fig. 9

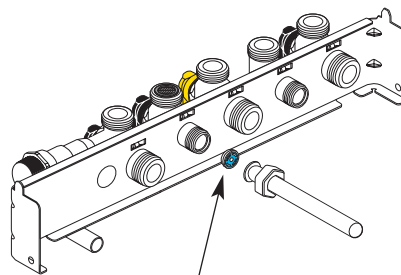

Fig. 10

Place the boiler on the wall on the hanging bracket. Using (fig. 16) for reference, connect the gas and water pipes and the valves to the base of the appliance using the tails provided. There is a 190 mm space between the valves and the wall to make these connections.

Connecting the boiler to the system

Attention ! Connecting tails are delivered with the boiler. You could ask your local dealer or Chaffoteaux et Maury Ltd for first installation tails kit or to replace existing boilers such as old Chaffoteaux et Maury models.

Before fitting the tails onto the connecting bracket, please check the correct location of the flow restrictor L (fig.10) on the main inlet.

Safety valve drains

The pressure relief valve tube is clear silicone. It should terminate below the boiler over a tundish or 22 mm pipe (see I fig 4) which should in turn discharge safely outside the premises. Care should be taken that it does not terminate over an entrance or window or where a discharge of heated water could endanger occupants or passers by.

The system should be carefully checked for leaks, as frequent refilling could cause premature system corrosion or unnecessary scaling of the heat exchanger. The pipe should be connected to a drain in the conditions described in the relevant British regulations.

Fitting the Horizontal Flue

The instructions for the vertical and biflux (twin pipe) flue options are included with the relevant adapter kits.

The standard flue supplied with the appliance is suitable for lengths from 300 mm minimum to 720 mm maximum. This means for rear flueing, the standard kit will accommodate a maximum wall thickness of 600 mm, and for side flueing a maximum wall thickness of 587 mm. This takes into account the minimum appliance side clearances of 5 mm.

If the fixing is a rear exit flue, the template provides the position of the centre for drilling the flue hole with a core drill.

If the flue is a side exit installation then calculate the position of the hole with a slope of 5 mm / metre away from the boiler to the terminal. The flue should fall slightly to the terminal.

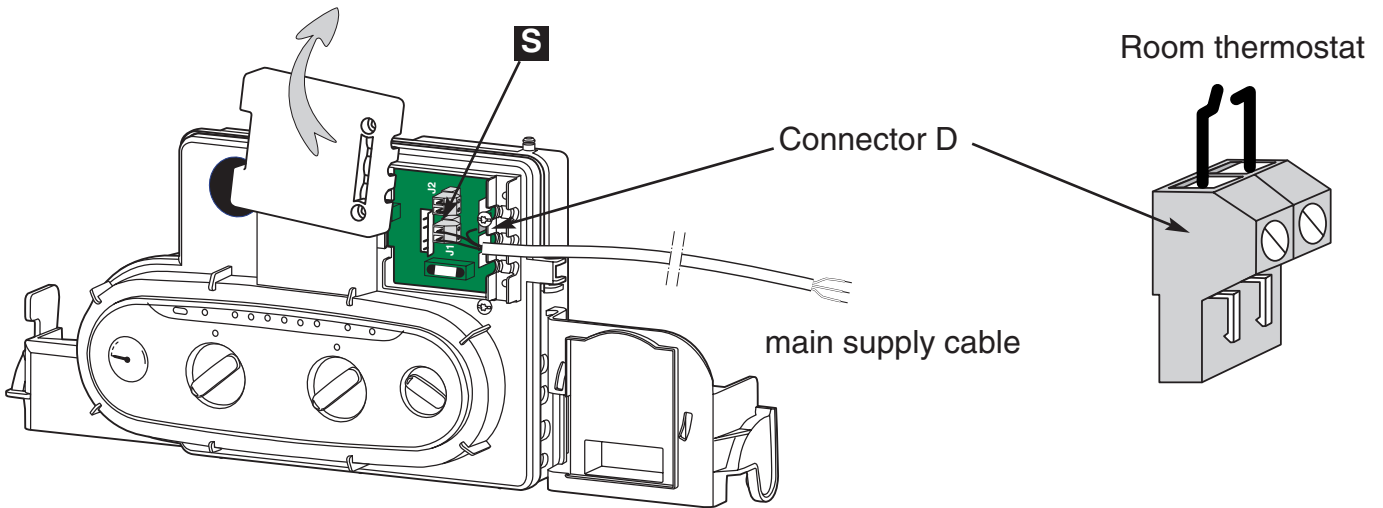

Fig. 11

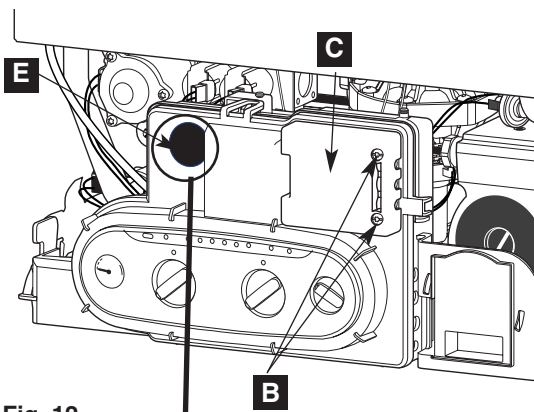

Fig. 12

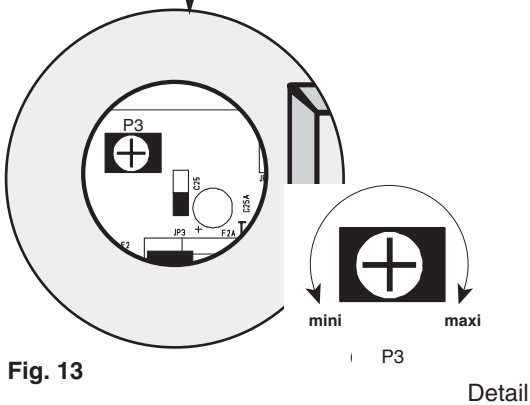

Fig. 13

Detail

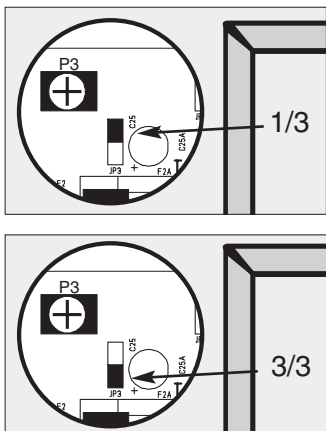

Fig. 14

Making the Electrical Connections:

Connect the live and neutral wires of the main cable. Note: The connections should be made so that should the lead be pulled from its anchorage, the current carrying wires become taut before the earth wire.

If using a room thermostat or other external control, undo the two retaining screws **B**, remove cover **C** (fig 12), they can be connected in place of the link on the multipin plug **D**. Connect multipin plug into the socket on the power board. Replace the cover.

ADJUSTMENT**Choice of mode :**

- Function without room thermostat bridge **S** remains in place.
- Function with room thermostat remove bridge **S**, room thermostat connected as shown on connector **D** (fig. 11).

The external control switches both burner and pump. The external control switches the pump off after a delay of 3 min 30'

Choice of boiler operation :

In order to make these adjustment you will need to access the front of the electrical box.

Isolate mains electrical supply to boiler.

Remove boiler outer casing.

Remove rubber cover **E** (fig. 12) on face of electrical box.

Adjustment on the PCB Central Heating Mode (fig. 13) :

- P3 : potentiometer TAC (Temporisation Anti Cycle) may now be adjusted between 30 seconds and 3 minutes (see detail) (factory set at 3 minutes).
- JP3 : the spade connector (fig. 14) allows the gas rate to be reduced to 1/3 performance by positioning spade across pins as shown (fig. 14). Full performance across pins as shown (fig. 14).

After completing adjustments replace rubber cover and refit outer casing.

The boiler is suitable for sealed systems only. The maximum cold water mains pressure for the appliance is 10 bar. All fittings and pipework connected to the appliance should be of the same standard. If there is a possibility of the incoming mains pressure exceeding 10 bar, particularly at night, then a suitable pressure limiting valve must be fitted.

The boiler is designed to provide hot water on demand. If there is a requirement for greater demands, for example if the property has several bathrooms and cloakrooms, a vented or unvented hot water storage system should be used.

Showers

Any shower valves used with the appliance should be of a thermostatic or pressure balanced type. Refer to the shower manufacturer for performance guidance and suitability.

Flushing and Water Treatment

The performance of the appliance could be impaired by system debris or the effects of corrosion. The system must be flushed thoroughly to remove metal filings, solder, machining oils and other fluxes and greases before connecting the boiler. If it is an existing system, an appropriate flushing and descaling agent should be used. Refer to BS 7593 (1992) for guidance. For more information on the use of corrosion inhibitors, flushing and descaling agents, advice can be sought from the manufacturers of water treatment products such as:

Betz Dearborn Ltd
 Foundry Lane
 Widnes
 Cheshire
 WA8 8UD
 Tel: 0151 424 5351

Fernox Manufacturing
 Britannica Works
 Clavering
 Essex
 CB11 4QZ
 Tel: 01799 550811

System Controls

The boiler is electrically controlled and is suitable for most modern electronic time and temperature controls. The addition of such external controls can be beneficial to the efficient operation of the system. The boiler connections for external controls are 24V and so only controls of 24V or that have voltage free contacts should be used.

By pass and Pump

The boiler is fitted with an automatic by pass. Although adjustment is not necessary.

Expansion Vessel

The expansion vessel is pre-charged to 0.7 bar (10 lb/in²). The vessel is suitable for systems up to 145 litres capacity. For systems of greater capacity an additional expansion vessel will be required. Refer to the chart below and BS 7074 pt 1 or BS 5449.

Filling Point

Provision must be made to be able to charge the system on commissioning and to make up any subsequent pressure loss.

The method of connection must utilise approved equipment and must comply with the water regulations. A filling loop can be so installed as to be hidden beneath the boiler.

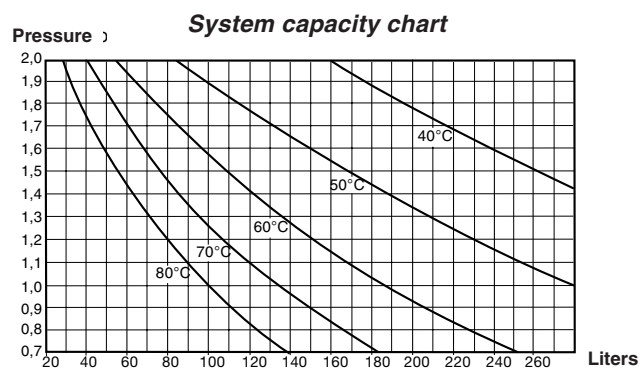

Fig. 15

Pre-commissioning

Ensure that the system has been adequately flushed.
Purge gas supply of air and test for soundness.
Carry out final electrical tests to ensure the correct polarity and earthing continuity.

DHW

Open the main cold feed valve.
Open all hot taps to purge DHW system.
Check for water soundness.
Check flow rate at the bath tap is set correctly (see technical data).

Central Heating

Open flow and return valves on the boiler **34** and **38** (fig 16)
Open the automatic air vent **9** (fig 16)
Fill system and vent radiators.
Set system pressure and remove filling loop.
Check for leaks.
Manually check pump is free to turn.
Switch on electrical supply.
Turn selector switch **23** (fig 17) to position **I**
Turn the boiler thermostat to maximum.
Allow pump to run for several minutes.
Isolate electrical supply.
Drain boiler and check water filter for installation debris.
Replace filter and recharge system.

Lighting the Boiler

Connect gas pressure gauge to test point **14** (Fig. 16).
Turn on the gas supply and boiler gas tap **36** (Fig. 16).
Ensure electrical supply is on.
Ensure all external controls are calling for heat.
Turn selector switch **23** (fig. 17) to position **I**.

Turn the boiler thermostat to maximum **25** (fig 17).
The boiler will light.
Allow the boiler to heat system.
Check the inlet gas pressure (working pressure) while boiler is operating in hot water mode.(Refer to technical data).
Check the operation of the boiler controls and safety devices.(see separate servicing leaflet for details)
Set the by pass (Refer to system guidance).
Re-flush the system to remove any dissolved oils and fluxes.
Recharge system pressure and introduce any water treatment as required.

Post Commissioning

Ensure system pressure has been set correctly.
Set boiler thermostat and controls.
Set programmer to householder's requirements.
Set external controls.
Ensure the Logbook is fully completed with your contact details and required readings and details of the installation.

Handing Over to the Householder

Demonstrate the lighting and operation of the boiler.
Demonstrate how to maintain the system pressure.
Demonstrate the operation and setting of the built-in clock.
Explain the benefits of annual maintenance by a competent person.
Explain how to register guarantee.
Ensure the Householder countersigns the Logbook to confirm that these demonstrations have been carried out and understood.

Detail for the adjustment of the by-pass

Cut of screw on - :
by pass shut

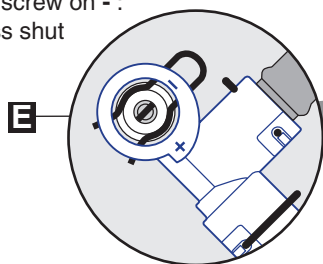

Cut of screw on + :
by pass open

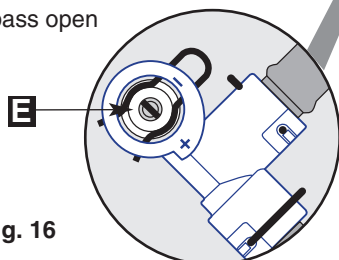
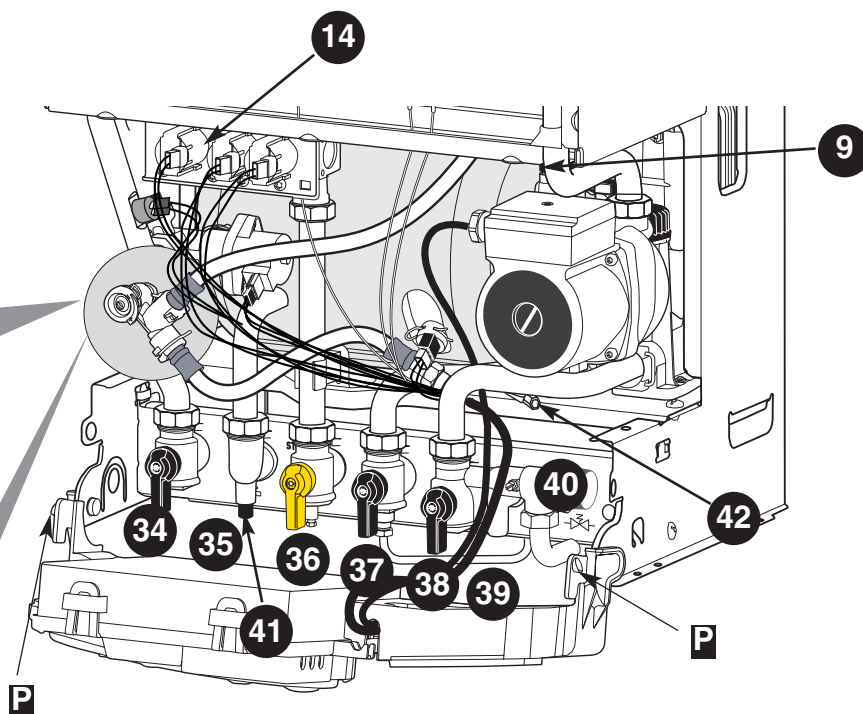

Fig. 16



Control panel (fig 17)

23. Two position Selector switch

○ = Switched OFF

I = Switched ON

24.  = Domestic hot water temperature control knob

25.  = Heating flow temperature control knob

26. Heating temperature indicator lights

27.  Green indicator - Power ON

28.  Orange indicator - Burner ON

29.  Red indicator - Lock out / flame failure

30 "RESET" Reset button

31. Pressure gauge

32.  = DHW mode indicator

33.  = Heating mode indicator

Isolating Taps (fig 16)

taps shown in Open position

34. CH Flow isolating valve

35. Domestic hot water outlet

36. Gas service tap

37. Water service tap

38. CH Return isolating valve

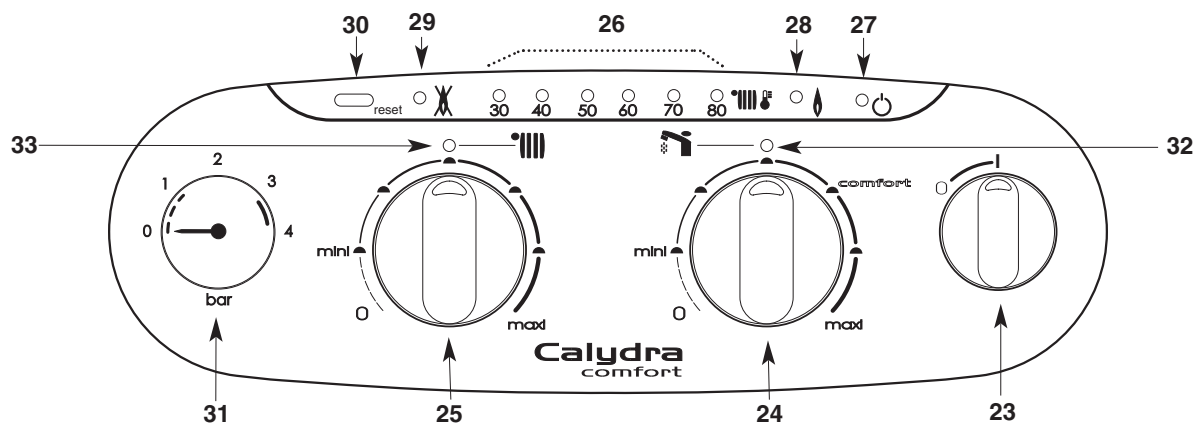



Fig.17



Switching on

- 1) Check that the gas service tap is opened at the gasmeter and main power is on.
- 2) Check that pressure in central heating system is above 0.7 bar and below 1.5 bar with the pressure gauge 31.
- 3) Open the gas tap 36.
- 4) The boiler is now ready to use.

Hot Water

- 1) Turn main switch 23 to position I. The green "power on" indicator 27  will light.
Turn the DHW temperature control knob clockwise 24. The DHW indicator will light 32.
- 2) Turn on a hot water tap, the orange "burner on" indicator  will light 28 and the water will become hot.

Heating

- 1) Turn main switch 23 to on position I. The green "power on" indicator  will light 27.
Turn the CH temperature control knob clockwise 25. The CH indicator will light 33.
- 3) If the room thermostat (if fitted), the boiler temperature control  and the clock (if fitted) are all calling for heat, the orange "burner on" indicator  will light and the heating will be on.

When there is a need for hot water while the heating is on, it is only necessary to turn on a hot tap. The heating will be interrupted momentarily while the hot water is being delivered. The boiler will switch back automatically to heating when the tap is turned off.

Note: If the boiler has been turned off for some time the first attempt to light it may result in a lockout . If this happens press the reset button 30 and the boiler will light.

To Turn Boiler Off Completely

- 1) Turn the main switch 23 to the off position ○.
- 2) Turn the gas tap 36 OFF.

1. General layout

The mechanical clock covers a 24 hour period. Each tappet represents 15 minutes **A** (fig. 19). An override switch is located on the clock **B** (fig 19).

2. To set the time

To set the time of day, grasp the outer edge of the dial and turn slowly clockwise until the correct time is lined up with the arrow **C** (fig. 19).

3. To Set the "On" and "Off" times

The clock uses a 24hours system. e.g. 8 =8.00 am and 18 = 6.00 pm "ON" periods are set by sliding all tappets between the "ON" time and the "OFF" time to the outer edge of the dial. The tappets remaining at the centre of the dial are the "OFF" periods.

4. To select function mode

Put the selector switch **B** to symbol ☉ to control the boiler by the clock. Put the switch **B** to «I» to select permanent operation or to «0» to turn heating off permanently.

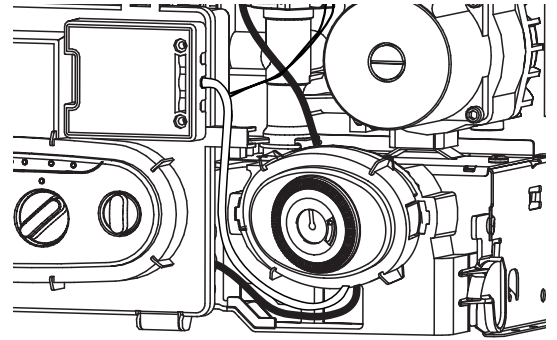

Fig. 18

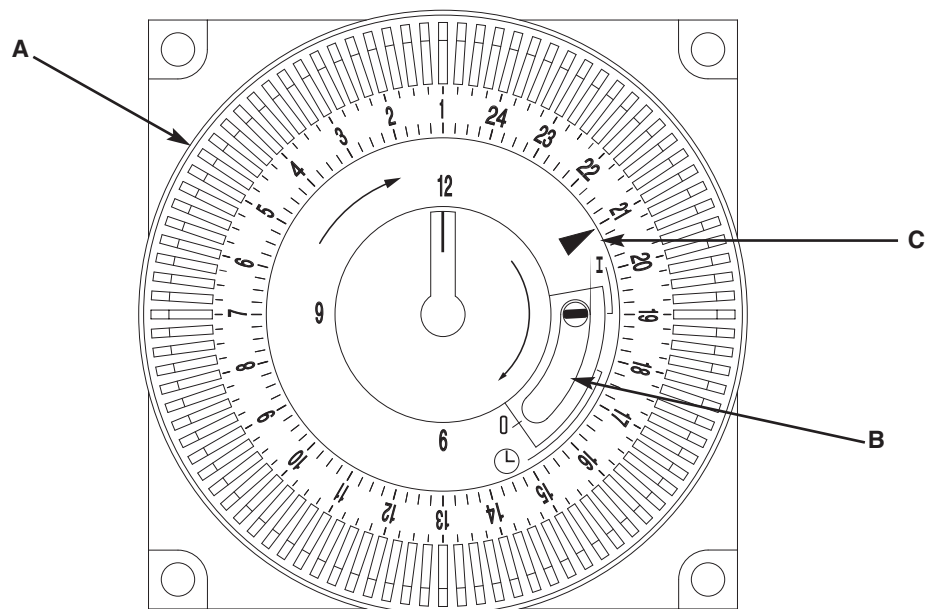

Fig. 19

Incorrects functions is signalled by leds (rep 26) display flashing correspond with chart below.

CODE						FAULT	INFORMATION
30	40	50	60	70	80		
<input type="radio"/>	<input type="radio"/>	<input type="radio"/>	<input type="radio"/>	<input type="radio"/>	<input checked="" type="radio"/>	Overheating safety feature	
<input type="radio"/>	<input type="radio"/>	<input type="radio"/>	<input type="radio"/>	<input checked="" type="radio"/>	<input type="radio"/>	Overheating defect without locking	
<input type="radio"/>	<input type="radio"/>	<input type="radio"/>	<input type="radio"/>	<input checked="" type="radio"/>	<input checked="" type="radio"/>	Misfiring safety feature	
<input type="radio"/>	<input type="radio"/>	<input type="radio"/>	<input checked="" type="radio"/>	<input type="radio"/>	<input type="radio"/>	Fire detection without burner working	
<input type="radio"/>	<input type="radio"/>	<input type="radio"/>	<input checked="" type="radio"/>	<input type="radio"/>	<input checked="" type="radio"/>		Besides freezing pump
<input type="radio"/>	<input type="radio"/>	<input type="radio"/>	<input checked="" type="radio"/>	<input checked="" type="radio"/>	<input type="radio"/>		Besides freezing burnerr
<input type="radio"/>	<input type="radio"/>	<input type="radio"/>	<input checked="" type="radio"/>	<input checked="" type="radio"/>	<input checked="" type="radio"/>	Lack of water circulation.	
<input type="radio"/>	<input type="radio"/>	<input checked="" type="radio"/>	<input type="radio"/>	<input type="radio"/>	<input type="radio"/>	Primary water circulation defect	
<input type="radio"/>	<input type="radio"/>	<input checked="" type="radio"/>	<input type="radio"/>	<input type="radio"/>	<input checked="" type="radio"/>	Thermistor sanitary open	
<input type="radio"/>	<input type="radio"/>	<input checked="" type="radio"/>	<input type="radio"/>	<input checked="" type="radio"/>	<input type="radio"/>	Thermistor sanitary bypassed.	
<input type="radio"/>	<input type="radio"/>	<input checked="" type="radio"/>	<input type="radio"/>	<input checked="" type="radio"/>	<input checked="" type="radio"/>	Thermistor inlet heating open	
<input type="radio"/>	<input type="radio"/>	<input checked="" type="radio"/>	<input checked="" type="radio"/>	<input type="radio"/>	<input type="radio"/>	Thermistor inlet heating bypassed	
<input type="radio"/>	<input checked="" type="radio"/>	<input type="radio"/>	<input checked="" type="radio"/>	<input type="radio"/>	<input checked="" type="radio"/>	Extractor on and pressure regulator at rest	
<input type="radio"/>	<input checked="" type="radio"/>	<input type="radio"/>	<input checked="" type="radio"/>	<input checked="" type="radio"/>	<input type="radio"/>	Extractor off and pressure regulator at rest	
<input type="radio"/>	<input checked="" type="radio"/>	<input checked="" type="radio"/>	<input type="radio"/>	<input type="radio"/>	<input checked="" type="radio"/>	Thermistor cylinder open	
<input type="radio"/>	<input checked="" type="radio"/>	<input checked="" type="radio"/>	<input type="radio"/>	<input checked="" type="radio"/>	<input type="radio"/>	Thermistor cylinder bypassed	
<input type="radio"/>	<input checked="" type="radio"/>	<input checked="" type="radio"/>	<input checked="" type="radio"/>	<input type="radio"/>	<input checked="" type="radio"/>	Distribution valve stuck on heating	

= LED off

= LED blinking

Notes

Chaffoteaux & Maury are continuously improving their products and therefore reserve the right to change specifications without prior notice and accepts no liability for any errors or omission in the information contained in this document.

Manufacturer: **Chaffoteaux & Maury - France**

Commercial subsidiary: **MTS (GB) Limited**

MTS Building
Hughenden Avenue
High Wycombe
Bucks HP13 5FT
Telephone: (01494) 755600
Fax: (01494) 459775
internet: www.chaffoteaux.co.uk
E-mail: info@mtsgb.ltd.uk
Technical Support Help Line: (01952) 22288