



**CHAFFOTEAUX
& MAURY**

MAINTENANCE AND SERVICE GUIDE

Britony system II Plus 80 and 100 Central Heating Fanned Flue Boiler

Dimensions

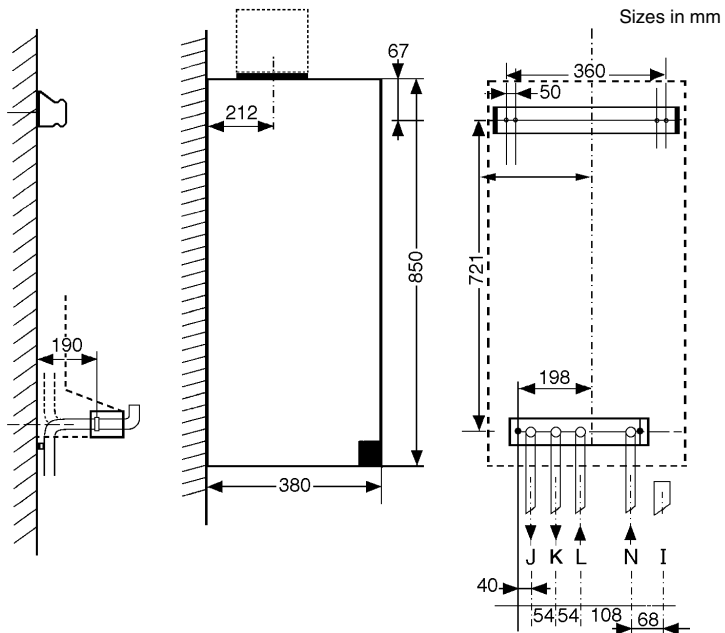
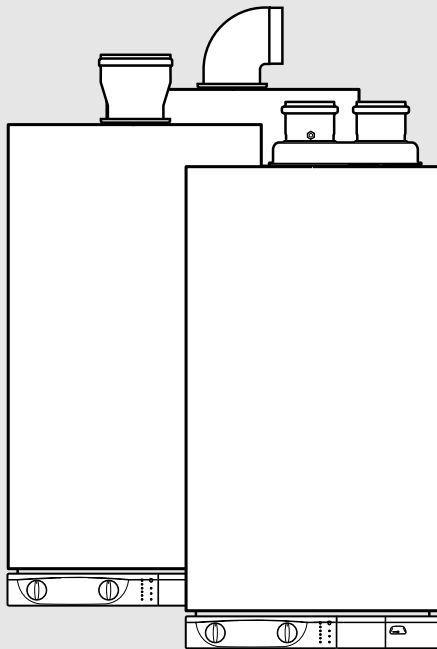

Boiler outer case dimensions :

- Height : 850
- Boiler width : 440 (minimum space required 450)
- Depth : 380

- I Safety valve outlet
- J Heating flow
- K H.W. flow
- L Gas supply
- N Heating return

Flue types:

- C 12 or 42: horizontal
- C 32 xx: vertical concentric
- C 32 xy: Twin flue

Technical data

Heat input C/H & HW	System 80 :	11.73 to 28,70 kW
	System 100 :	15.43 to 34.50 kW
Heat output C/H & HW	System 80 :	9.50 to 24 kW
	System 100 :	12.50 to 28 kW
Max. operating pressure C/H circuit :	2.5 bar	
Expansion vessel net capacity :	5.4 l	
Expansion vessel initial pressure :	0.7 bar	

Electrical consumption :	150 w
Voltage :	230 v
Electrical protection index :	IP24
Fuses :	2 A and 1.25 A
Gas category :	II 2E+ 3+

Nominal gas flow rate at 15°C and 1013 mbar

	BRITONY System II Plus 80		BRITONY System II Plus 100	
	Maximum power kW	Minimum power kW	Maximum power kW	Minimum power kW
-Natural gas (G 20) at 20 mbar	2.74 m ³ /h	1.22 m ³ /h	3.34 m ³ /h	1.57 m ³ /h
-Butane gas (G 30) at 28 mbar	2.04 kg/h	0.91 kg/h	2.45 kg/h	1.17 kg/h
-Propane gas (G 31) at 37 mbar	2.00 kg/h	0.89 kg/h	2.42 kg/h	1.15 kg/h

Injectors and gas valves seat diameter

	BRITONY System II Plus 80		BRITONY System II Plus 100	
	Natural gas	Butane or Propane	Natural gas	Butane or Propane
-Blue solenoid restrictor diameter	2.60 mm	1.75 mm	2.90 mm	2.00 mm
-Gas valve restrictor diameter	6.70 mm	4.90 mm	no restrictor required	6.70 mm
-Manifold injectors (16)	1.23 mm	0.70 mm	1.26 mm	0.76 mm

Pump and expansion vessel characteristics

PUMP HEAD AVAILABLE

Minimum flow rate (with all heating thermostatic valves closed)
mCE

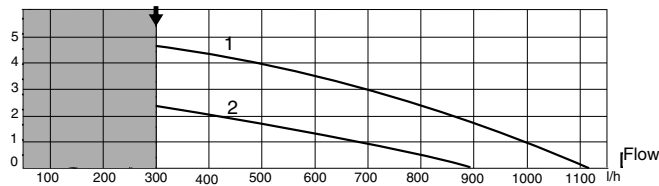

1 = by-pass closed
2 = by-pass open

Head available / flow

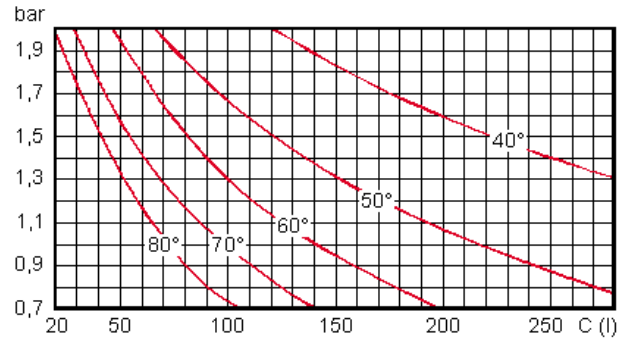

Note : The system initial pressure should be over the following value :
 $\frac{\text{System static height (in metre)} + 0.7}{10} = \text{Initial pressure (in bar)}$

Components location

1. CH Flow isolating valve
2. HW Flow isolating valve
3. Gas service tap
5. CH Return isolating valve

7. Pressure relief valve
8. Chassis
9. Connecting tails (x 5)

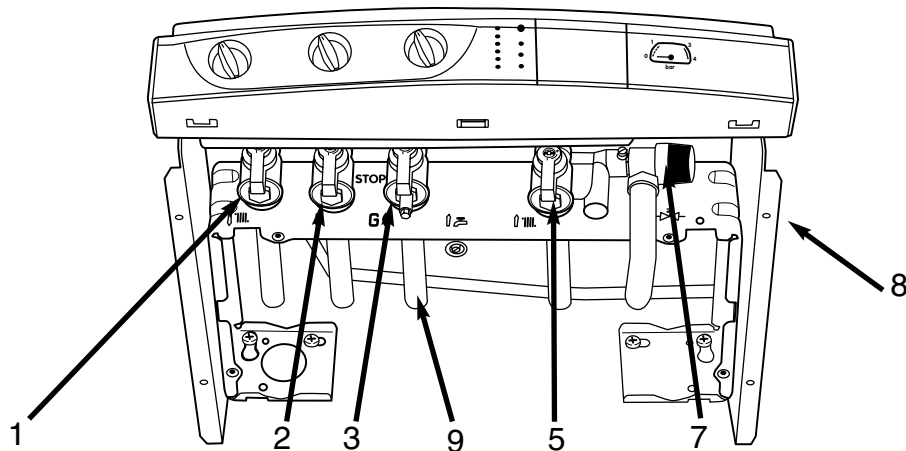

10. Steel chassis complete with expansion vessel
11. Sealed chamber
12. Expansion vessel (not visible)
13. Overheat thermostat
14. Electrical box
15. Two position selector switch
17. Heating flow temperature adjustment
18. CH pressure gauge
20. Green indicator - Power ON
21. Orange indicator - Burner ON
22. Red indicator - Lock out / flame failure
23. Reset button

24. Multigas burner comprising:
 - 25. 16 burner head
 - 26. Manifold
 - 27. 2 Ignition electrode
 - 28. Ionization electrode
29. Gas section comprising:
 - 30. Security valve (grey)
 - 31. 1/3 gas stage (blue)
 - 32. 2/3 gas stage (black)
33. Right hydraulic assy
34. Left hydraulic assy
35. Pump
36. Air separator
37. Heating thermistor



39. Combustion chamber made of aluminium coated steel with 4 ceramic fibre panels to insure heat insulation
40. Copper main exchanger
42. Three way valve
43. Connecting bracket
45. Heating flowstat
46. Flue hood
47. Adjustable by-pass
49. Air Pressure switch
50. 45° elbow including venturi
51. Fan
- K. Flue kit fixing point (refer to kit manual)

FUNCTIONING

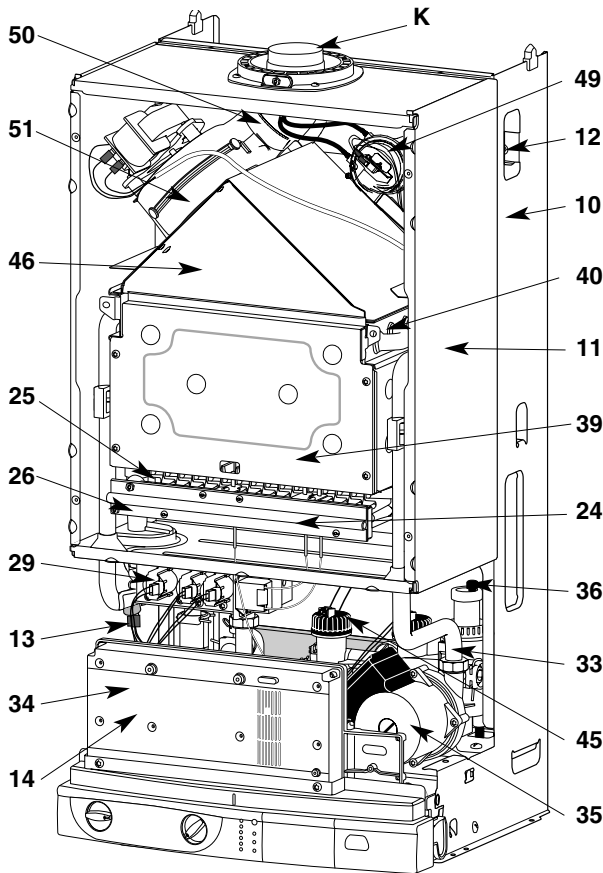

COMPONENTS LOCATION







Switching on

- 1) Check that the gas service tap is opened at the gasmeter and main power is on.
- 2) Check that pressure in central heating system is above 0.7 bar and below 2.5 bar with the pressure gauge  18.
- 3) Open the gas tap 3 by turning from right to left. 
- 4) The boiler is now ready to use.

Hot Water

- 1) Turn selector switch 15 to position . The green "power on" indicator  (20) will light.
- 2) The orange "burner on" indicator  (21) will light and the cylinder will be heated.

Heating and Hot Water

- 1) Turn selector switch 15 to position  . The green "power on" indicator  will light.(20)
- 2) If the room thermostat (if fitted), the boiler temperature control  and the clock (if fitted) are all calling for heat, the orange "burner on" indicator  will light and the heating will be on.

Control panel

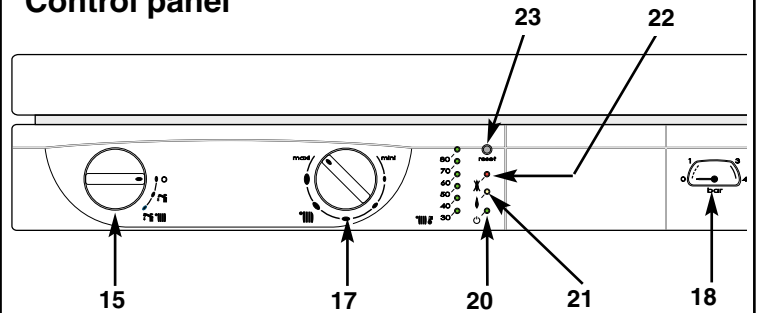

BRITONY System II plus FUNCTIONAL DIAGRAM

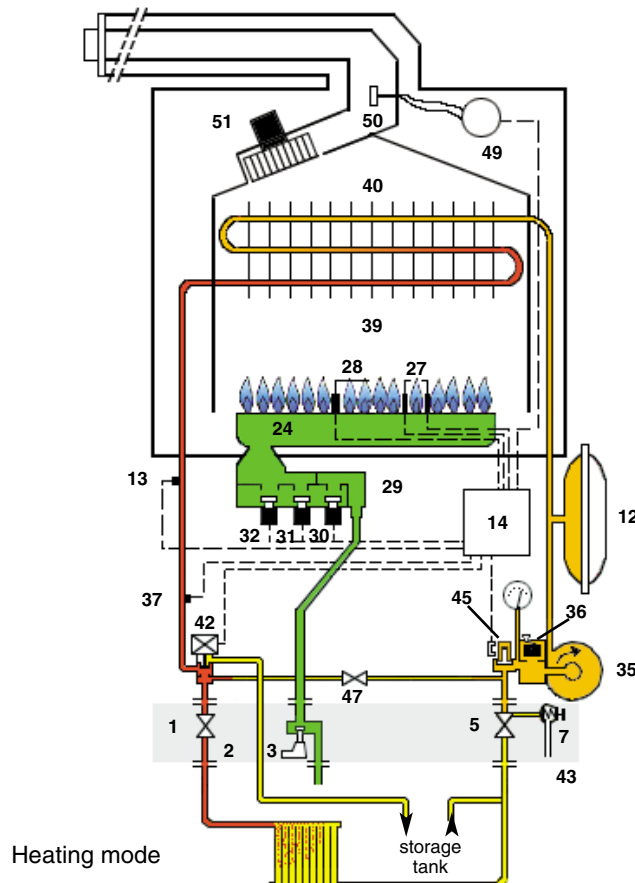

When there is a need for hot water tank reheating while the heating is on. The heating will be interrupted momentarily while tank is reheated. The boiler will switch back automatically to heating when the tank is at temperature.

Note: If the boiler has been turned off for some time the first attempt to light it may result in a lockout \times 22. If this happens press the reset button 23 and the boiler will light.

Domestic Hot Water Mode

To be able to supply hot water, the selector switch 15 must be in either on \uparrow or \uparrow III position. This will be confirmed by the green indicator light \odot 20

When the aquastat of the tank is on, it activates the DHW flow switch 44 and allow the 3 way valve 42 to move to the HW position. The pump can now circulate primary water heated by the main heat exchanger through the tank heat exchanger.

The first stage solenoid 31 (blue) and security solenoid 30 (grey) open together to allow gas to the burner. The ignition sequence begins and a continuous high speed spark ignites the gas. As soon as a flame is detected the orange indicator bulb \uparrow 21 will light and the second stage solenoid 32 (black) opens to allow the full gas rate. If a flame is not detected, after 8 seconds, the security solenoid closes and shuts off the gas. The red lockout indicator bulb \times 22 will light. The water flow temperature is controlled by the central heating control thermistor 37. When the tank is at temperature, the

burner is extinguished and the pump stops. The boiler will now stay in the hot water mode for three minutes.

Priority will be given to a demand for hot water tank reheating. This will interrupt the central heating for the duration of hot water tank reheating.

Central Heating Mode

To be able to supply heating, the selector switch 15 must be on \uparrow III position. This will be confirmed by the green indicator light \odot 20.

When there is a demand for heating (either from the room thermostat or the clock) the pump starts. If the boiler temperature control is calling for heat and primary flow rate over 4 ltr/min, the central heating flow switch operates allowing the ignition sequence to begin. The first stage solenoid 31 (blue) and security solenoid 30 (grey) open together to allow gas to the burner. The ignition sequence begins and a continuous high speed spark ignites the gas. As soon as a flame is detected the orange indicator bulb \uparrow 21 will light. After 45 seconds the second stage solenoid 32 (black) opens to allow the full gas rate. If a flame is not detected, after 8 seconds, the security solenoid closes and shuts off the gas. The red lockout indicator bulb \times 22 will light.

The central heating flow temperature is controlled by the central heating control thermistor 37. The boiler has been designed to minimise cycling and will not attempt to relight for at least 3 minutes

after the boiler thermostat has been satisfied. When the room thermostat is satisfied the burner will switch off and the pump will remain running for a further 3 minutes before it too stops.

NB

It is possible to override the 3 minute delay by pressing the RESET button 23.

Lock out procedure

Flame disappearance :

When the ionisation electrode 28 does not detect flame presence. The orange indicator lamp 21 extinguishes. A lighting cycle starts. If a flame is not detected before 8 seconds, the grey security solenoid 30 and the blue 1/3 solenoid 31 will close. The lock out red indicator 22 lights, the pump 35 runs and the 3 way valve 42 stays in its position.

After a few seconds, it will become possible to reset the boiler by pressing the reset button 23.

Overheat detection :

If an overheat is detected by the sensor 13, the grey security solenoid 30 and the blue 1/3 31 closes, the orange indicator lamp 21 extinguishes. The ignitor is energised for 8 seconds and the red lockout indicator 22 lights. If the burner cannot relight the boiler will go to lockout.

WIRING

DIAGRAM

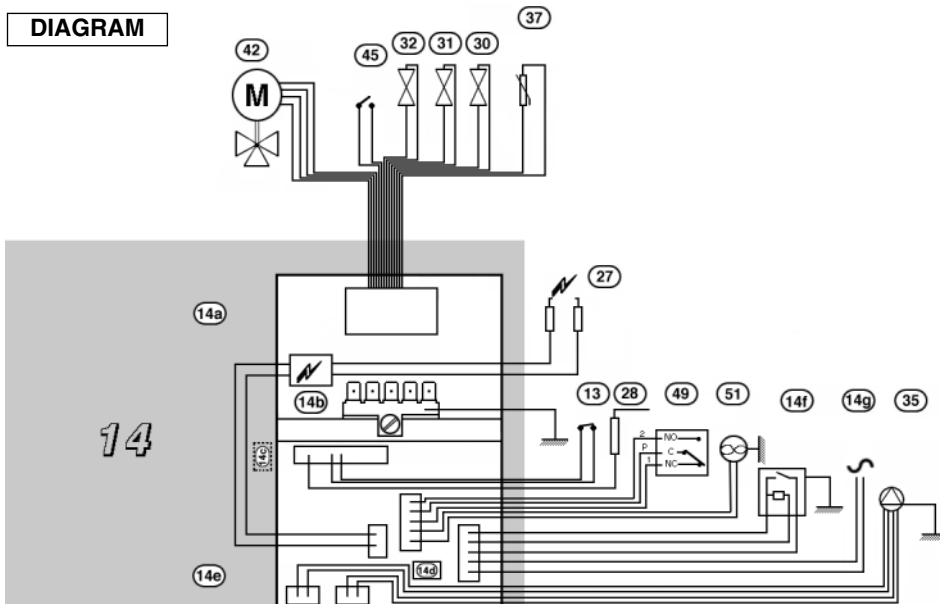

Plug for main power and Room thermostat connection

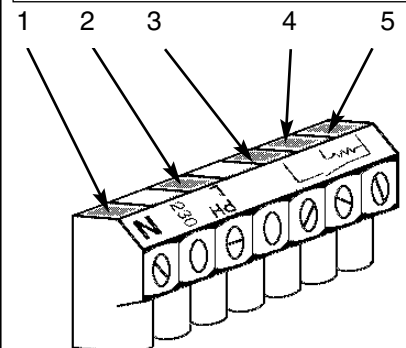

1. Neutral
2. Phase
3. Room thermostat live
4. Accelerator resistor
5. Common for Accelerator and room thermostat.

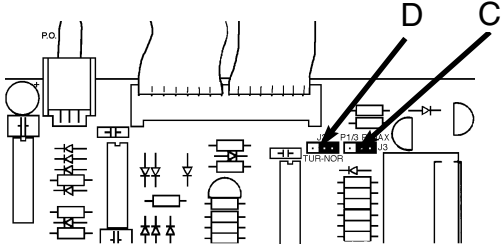
ELECTRICAL WIRING continuation			ADJUSTMENTS ON CONTROL PCB
N°	Designation	Wiring colours	<p>The following adjustments are available on the regulation PCB. To gain access to them, pivot down electrical box, remove the rear cover and the rear panel of electrical box, unplug connectors from regulation PCB and pull it toward you.</p> <p>Heating output limitation :</p> <ul style="list-style-type: none"> - Functioning without limitation plug C on "P MAX" - Functioning at 1/3 gas rate only plug C on "P 1/3" <p>Burner functioning:</p> <ul style="list-style-type: none"> - Regulation available 3/3, 1/3, 0 plug D on "NOR" - Functioning at full gas rate only plug D on "TUR" 
13.	-Overheat sensor	Brown	
14.	-Electrical box		
14a.	-Regulation PCB		
14b.	-Ignitor	Red, Black	
14c.	-Fuse 1.25 A		
14d.	-Fuse 2A		
14e.	-Power PCB		
14f.	-Room thermostat		
14g.	-Mains 230V 50 Hz		
18.	-Pressure switch	2: Black P: Orange 1: White	
27.	-Spark electrodes	White	
28.	-Ionisation probe	White	
30.	-Security solenoid (grey)	Grey	
31.	-2/3 gas stage solenoid (black)	Black	
32.	-1/3 gas stage solenoid (blue)	Blue	
35.	-Pump		
37.	-C/H thermistor	Violet	
38.	-DHW thermistor	Green	
42.	-3 way valve	White, Yellow, Orange	
44.	-DHW flow switch	Brown	
45.	-C/H flow switch	Red	
51.	-Fan	Brown, Blue	

REGULATION	ROUTINE SERVICING	
<p>Temperature regulation for both C/H and DHW circuits are controlled by 2 thermistors. The C/H knob allows the adjustment of temperature between 35 and 85°C. The DHW temperature is limited to 60°C. DHW and C/H thermistors are identical and interchangeable.</p> <p>Resistance value are</p> <ul style="list-style-type: none"> -5000 Ω at 25 °C -2631 Ω at 40°C -620 Ω at 80°C -255 Ω at 110°C 	<p>To ensure continued efficient operation of the appliance, it is recommended that it is checked and serviced as necessary at regular intervals. The frequency of servicing will depend upon the particular installation condition and usage, but in general, once a year should be adequate.</p> <p>It is the law that any service work must be carried out by a competent person such as your local Chaffoteaux Service Centre, British Gas or other CORGI registered personnel in accordance with the current Gas Safety (Installation and Use) Regulations.</p> <p>The service schedule should include the following operations:</p> <ul style="list-style-type: none"> - Check the pressure in the system. - Check the correct operation of the appliance. - Check the correct operation of the gas controls. - Check the functions of the safety controls. - Check combustion chamber insulation panels for damage. - Clean the burner. - Clean the heat exchanger. - Check the burner manifold injectors. - Clean gas and water filters. - Check expansion vessel charge pressure. - Clean and check operation of safety valve. <p>Additional Procedures that may be necessary:</p> <ul style="list-style-type: none"> - Check burner pressure and gas flow rates. 	<ul style="list-style-type: none"> - Check that the fan blades are clean. - Check, clean and replace components as necessary. - Carry out combustion test utilising the test points in the flue turret. <p>SUGGESTED SEQUENCE for SERVICING</p> <p>Before disconnecting or removing any parts, isolate the gas and electricity supplies. Ensure that the appliance is cool.</p> <p>(for detail please see section on Parts Removal and Replacement)</p> <p>Preliminary Checks</p> <ul style="list-style-type: none"> - Remove outer case - Check the system pressure is at least 0.7 bar cold - Check operation of 1/3 and 2/3 solenoids. - Check that the burner is extinguished fully when both solenoids are closed in both DHW and C/H modes. - Test ionisation functions and check that lockout occurs by turning off gas tap. - Whilst boiler is operating, check operation of primary flow switch by closing heating flow valve and by pass screw (turn clockwise) noting the number of turns so that it may be reset correctly.
<p>FLOW SWITCHES</p> <p>Flow in both D.H.W. and Heating circuits are detected by 2 flow switches. A piston with a magnet at the top operates a REED switch. The piston is lifted by flow rates listed below :</p> <p>Flow rate threshold :</p> <ul style="list-style-type: none"> D.H.W. 120 l/h ±20 l/h C/H 250 l/h ±20 l/h 		
<p>AIR PRESSURE SWITCH</p> <p>The air flow rate is detected by a pressure differential created by a venturi located in the flue duct.</p> <p>ON threshold ΔP > 130 Pa OFF threshold ΔP < 100 Pa</p>		

REMOVAL AND REPLACEMENT OF PARTS

Before removing appliance case, isolate the gas and electrical supplies. Isolate boiler from the system and drain before removing any component in the waterways. Ensure that the appliance is cool.

1. Outer Case

Remove four screws in base of case

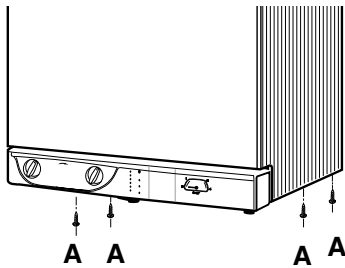

and lift free. When replacing, carefully locate on lugs T on top edge of chassis.

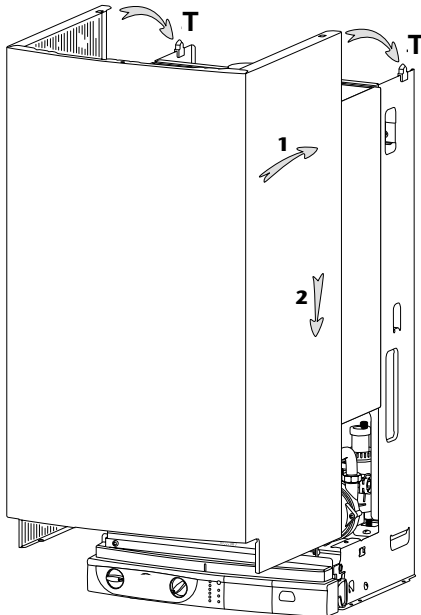

2. Combustion Chamber

Unscrew four self tapping screws securing the sealed chamber front panel and lift over top corner locating lugs. Unscrew four self tapping screws to release combustion chamber front plate and lift clear. Reassemble in reverse order.

3. Burner Manifold

Carry out steps 1 and 2 as above. Remove two screws securing the closure plate and the remaining four screws to release the manifold. Lift clear. Replace the manifold gasket. Reassemble in reverse order.

4. Ionisation Electrodes

Carry out steps 1 and 2 as above. Loosen screws securing the closure plate and remove. Disconnect the lead from the main wiring loom. Remove screw securing electrode to burner. Thread wire through grommet and lift clear. Reassemble in reverse order.

5. Ignition Electrodes

Carry out steps 1 and 2 as above. Hinge down electrical box by pressing retaining tabs P on either side.

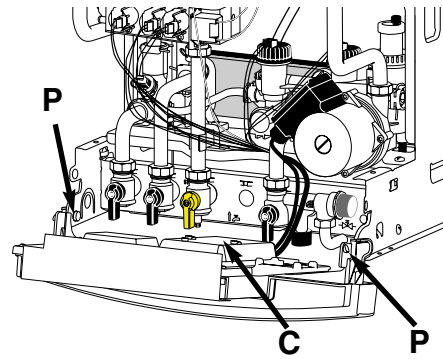

Remove wiring cover C. Disconnect leads from spark generator. Loosen screws securing the closure plate and remove. Remove grommet from base of sealed chamber. Remove screw securing electrode bracket and lift clear easing spade connectors through the grommet. Reassemble in reverse order, twisted together electrodes cable at least 10 times to avoid electrical interference.

6. Burner Assembly

Carry out steps 1,2, disconnect electrodes as mentioned in section 4 and 5. Remove two screws securing burner assembly to the back panel of the boiler. Lift right hand back corner first. Reassemble in reverse order.

7. Gas Solenoids

Disconnect colour coded leads. Remove six screws. The solenoids are attached to their base plate. Lift clear taking care not to lose the three plungers and springs. Reassemble in reverse order replacing the cork gasket.

8. Fan Assembly

Remove outer case and sealed chamber front panel (See Steps 1 and 2). Disconnect spade connectors noting positions. Remove two screws securing the front of the fan assembly and loosen screw on flue outlet. Twist fan assembly anticlockwise to disengage from flue outlet and lift clear.

Re-assemble in the reverse order ensuring that the wiring is re-connected correctly and the screw on the flue outlet tightened.

9. Flue Hood

Carry out steps 1 and 2 as above. Remove fan assembly as in step 8. Remove the three screws securing the angled top of the hood to the chassis. Lift and remove taking care not to snag the pressure switch cables. Re-assemble in the reverse order ensuring that the hood is located behind the combustion chamber rear panel.

10. Pressure Switch

Remove outer case and sealed chamber front panel as in steps 1 and 2. Disconnect three pressure switch cables noting their positions.

1 = white cable connected to NC
2 = black cable connected to NO
P = orange cable connected to C

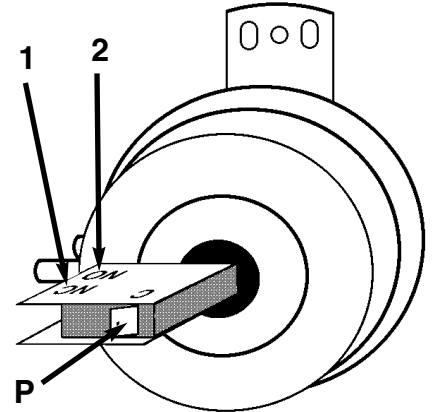

Remove screw securing the switch bracket to the chassis. Disconnect the sampling tubes again noting their positioning (+ and -). Remove switch. Reassemble in reverse order.

11. Pressure Switch Venturi

Carry out steps 1, 2 and 8, as above. Disconnect the sampling tubes and remove the screw securing the venturi to the flue outlet. Remove venturi by the bottom of the 45° elbow. Reassemble in reverse order.

12. Drain down

2 drain points are located on the boiler. H = Heating circuit drain point

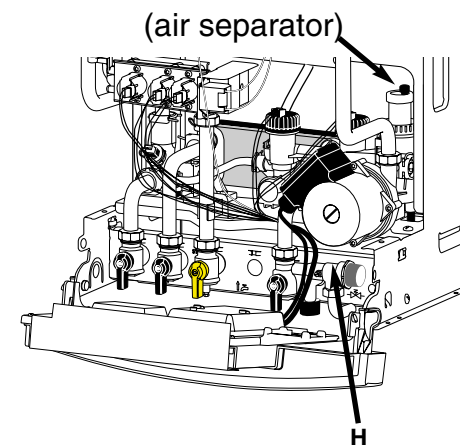

13. Water filter

The C/H filter is located in the right hydraulic assembly. Remove the return pipe as described previously and withdraw the filter. Reassemble in reverse order.

14. Flow switch

Drain boiler as in step 12. Disconnect the electrical plug, turn the top cover anti-clockwise, remove the O-ring and the brass piston. Reassemble in reverse order.

15. 3-Way valve

Drain boiler as in step 12. Remove the 3 clips on the 3 way valve. Remove the clip on the exchanger flow pipe. Pull the pipe down then pull it out of the 3 way valve. Disconnect the plug from the motor. Unscrew the nut on the pipe between the connecting bracket and the 3 way valve and pull it toward you. Rotate the 3 way valve body anti-clockwise to unclip it from the left hydraulic assembly.

17. Main heat exchanger

Carry out steps 1 and 2 as above. Drain boiler as in step 12. Remove the 2 clips **E** located on return and flow pipes and pull them downwards. Pull the main exchanger toward you to remove. Reassemble in reverse order.

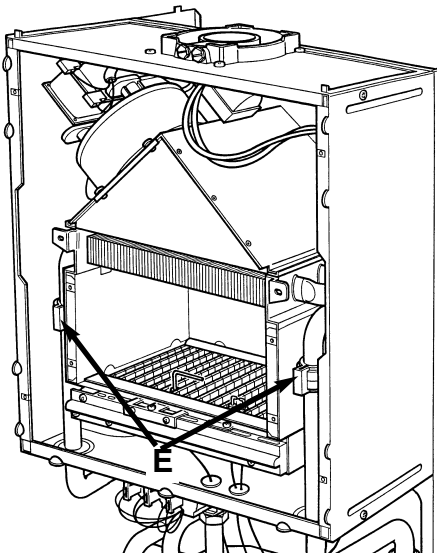

18. Pump

Drain boiler as in step 12. Pivot the electrical box downwards. Open the electrical box cover removing the 2 screws. Remove the pump plug from the power board and earth plug from earth socket.

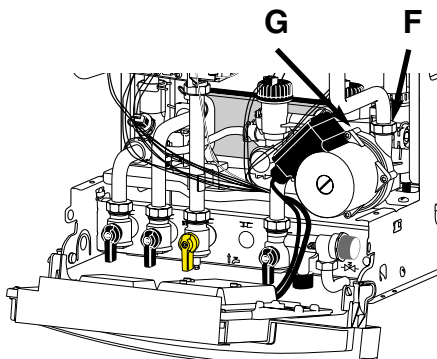

Unscrew the nut **F** of the return pipe from the volute. Remove the clip **G** on the pump volute and pull pump toward you. Reassemble in reverse order.

19. Pressure relief valve

The pressure relief valve can be serviced from the front of the appliance. Drain the boiler first, undo the retaining screw and pull out the valve. Reassemble in reverse order.

20. Thermistor

Drain the boiler as step 12. Disconnect the plug, remove the retaining clip pull the thermistor out. Reassemble in reverse order.

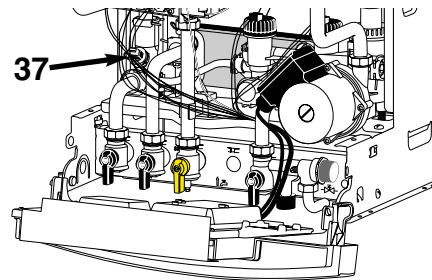

37 = Heating thermistor

21. Safety thermostat

Remove the casing as step 1 and hinge down the electrical box as step 5. Disconnect the 2 cables, pull out the sensor with the clip **13**.

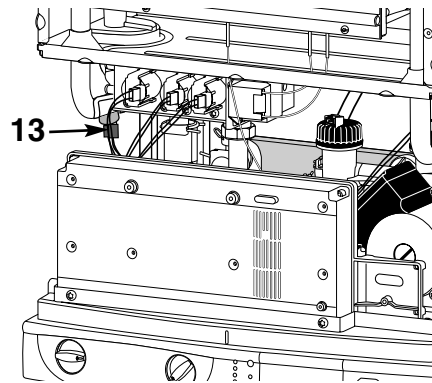

Reassemble in reverse order.

22. Spark generator

Carry out steps 1, 2, and open the electrical box cover as mentioned in step 5. Undo the 4 screws of the electrical rear panel and remove it. Unplug electrodes wires, remove the ignitor connector from the PCB, remove earth plug from earth socket. Hang out the ignitor. Reassemble in reverse order.

23. Power board

Carry out steps 1, 2, and open the electrical box cover as mentioned in step 5. Undo the 4 screws of the electrical rear panel and remove it. Unplug all cables from the PCB, remove earth plug from earth socket. Hang out the power board. Reassemble in reverse order.

24. Control board

Pull out plastic knob from the front panel and proceed as step 23. Reassemble in reverse order.

25. Expansion vessel

Remove the casing as step 1 and drain the boiler as step 12 above. Unscrew the connecting tails nuts and lift out the boiler from the wall. Place it on a side on the floor. Remove the expansion vessel bracket retaining screws, disconnect the pipe from the vessel and pull it toward you. Reassemble in reverse order.

FAULT FINDING CHART Part 1

PLEASE CHECK THE FOLLOWING POINTS CAREFULLY BEFORE GOING THROUGH THE FAULT FINDING CHART

- Gas pressure
- Electric mains
- Minimum water pressure in the heating circuit (over 0.8 bar)
- All isolating valves have been opened
- boiler air vented
- Check that the heating filter is clear.

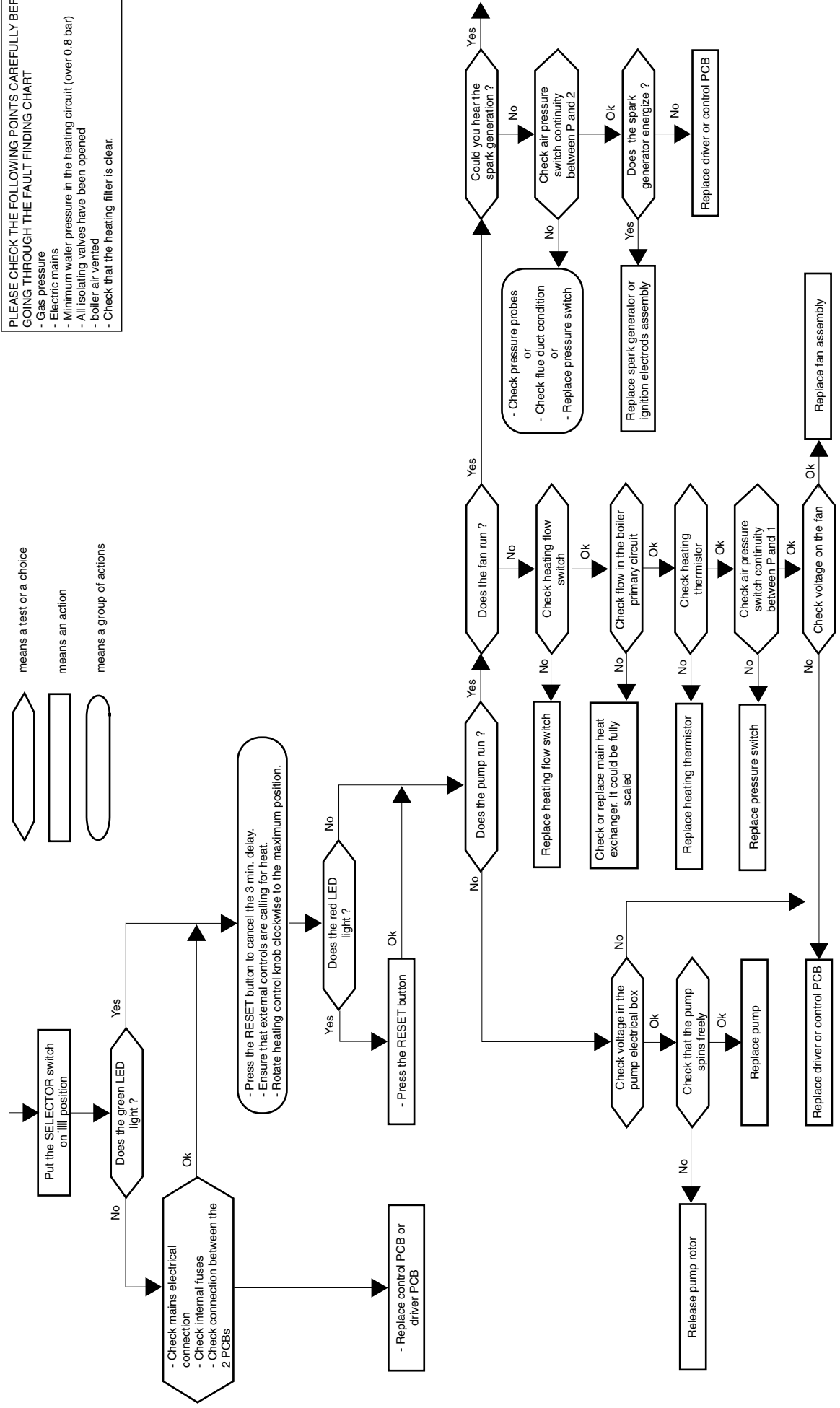
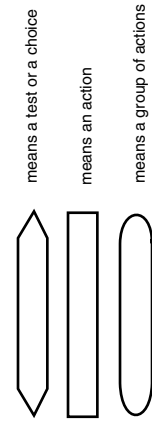

FAULT FINDING CHART Part 2

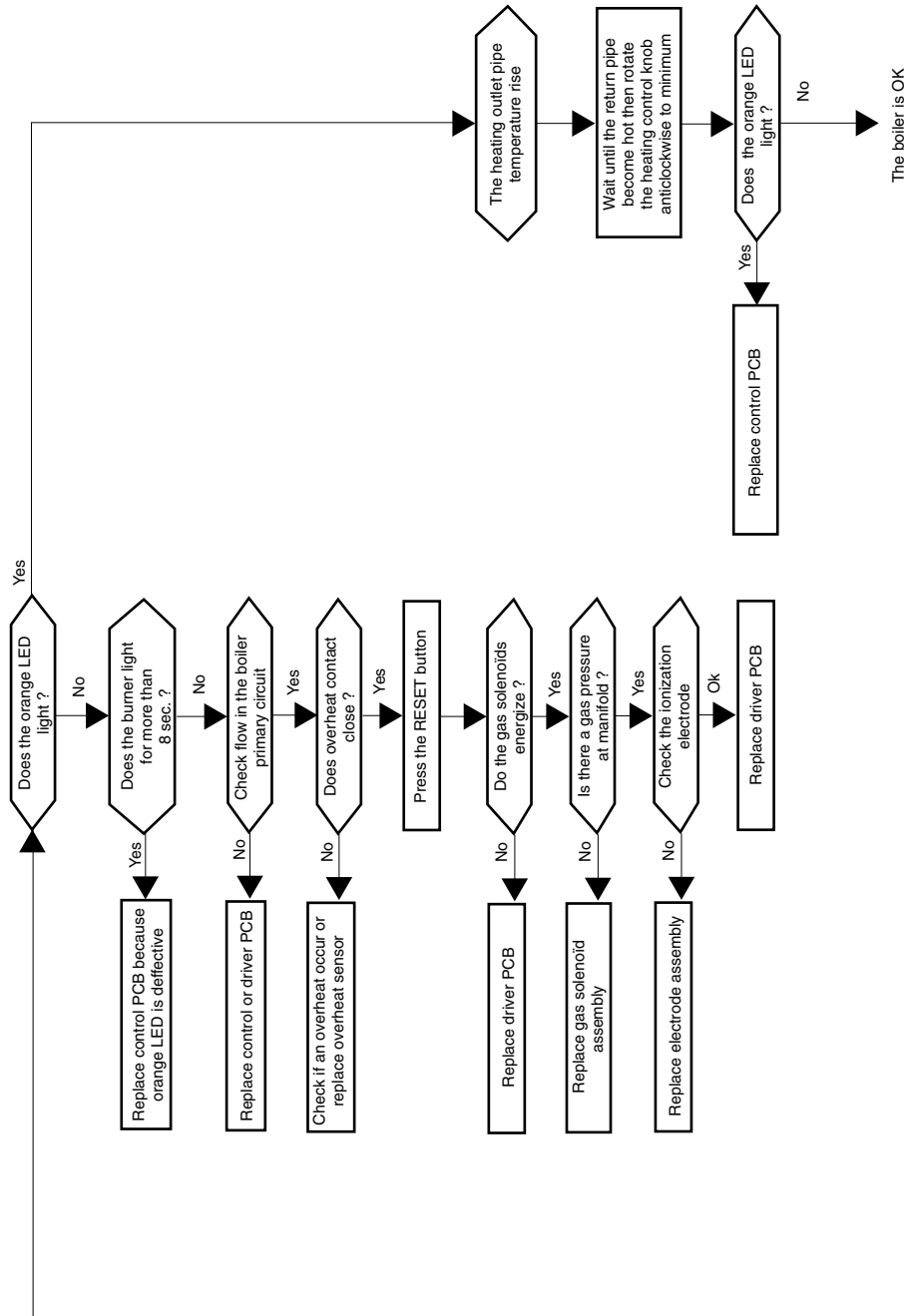

SHORT LIST

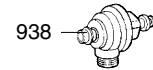
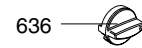
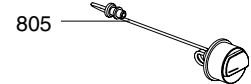
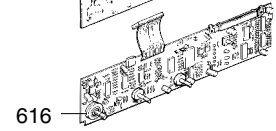
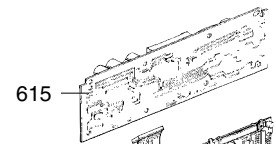
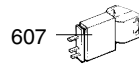
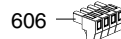
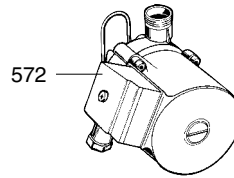
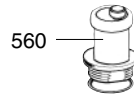
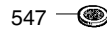
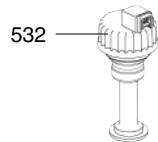
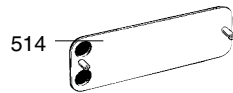
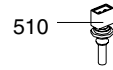
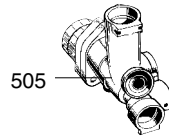
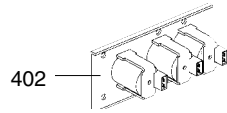
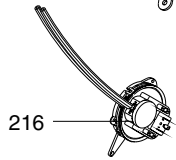
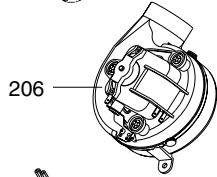
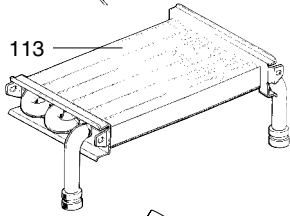
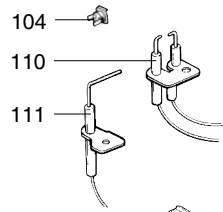

Key N°	Description	G.C N°	Manf. Pt. N°	Type	BRITONIX SYSTEM II		Manf. date	
					80	100	from	to
					FF	FF		
104	OVERHEAT THERMOSTAT 100°C	277783	1010572		•	•		
110	IGNITION ELECTRODE ASSY	277788	1002801		•	•		
111	IONIZATION ELECTRODE	277789	1002802		•	•		
113	HEAT EXCHANGER	277790	1010017		•			
	HEAT EXCHANGER	E00606	1011136			•		
206	FAN ASSY		1304720		•			
	FAN ASSY		1304721			•		
216	AIR PRESSURE SWITCH KIT		1306697		•			
	AIR PRESSURE SWITCH KIT		1307335			•		
402	SOLENOID VALVES KIT	E23494	81836		•	•		
505	THREE-WAY VALVE	277833	1010000		•	•		
510	THERMISTOR TEMP. SENSOR	277834	1000733		•	•		
514	SHUNT PLATE		1010611		•	•		
532	WATER THROTTLE	277846	81471		•	•		
547	GAS FILTER	263545	37309		•	•		
560	AIR SEPARATOR HEAD ASSEMBLY	277857	1002653		•	•		
572	PUMP UP 15/50 230V	E11662	1010612		•	•		
605	CONNECTOR	277872	1010349		•	•		
606	PRESSURE GAUGE		1011046		•	•		
607	IGNITER	379075	1002105.20		•	•		
615	PRINTED CIRCUIT BOARD OF POW.	277880	1010592		•	•		
616	PRINTED CIRCUIT BOARD OF REGU.	277881	1010047		•	•		
627	FUSE 250V 2A - TEMPORIZED	277883	1003456		•	•		
629	FUSE 250V 1.25A - TEMPORIZED	277884	1003635		•	•		
805	PRESSURE GAUGE		1303158		•	•		
636	KNOBS SET		1305158		•	•		
938	PRESSURE RELIEF VALVE		1020933		•	•		

Notes

Chaffoteaux & Maury are continuously improving their products and therefore reserve the right to change specifications without prior notice and accepts no liability for any errors or omission in the information contained in this document.

Manufacturer: **Chaffoteaux & Maury - France**

Commercial subsidiary: **MTS (GB) Limited**
MTS Building
Hughenden Avenue
High Wycombe
Bucks HP13 5FT
Telephone: (01494) 755600
Fax: (01494) 459775
internet: www.chaffoteaux.co.uk
E-mail: info@mtsgb.ltd.uk
Technical Support Help Line: (01952) 222288