

Please leave these instructions with the user

MAIN

MULTIPOINT BF Gas Fired Balanced Flue Water Heater

User Operating, Installation and Servicing Instructions

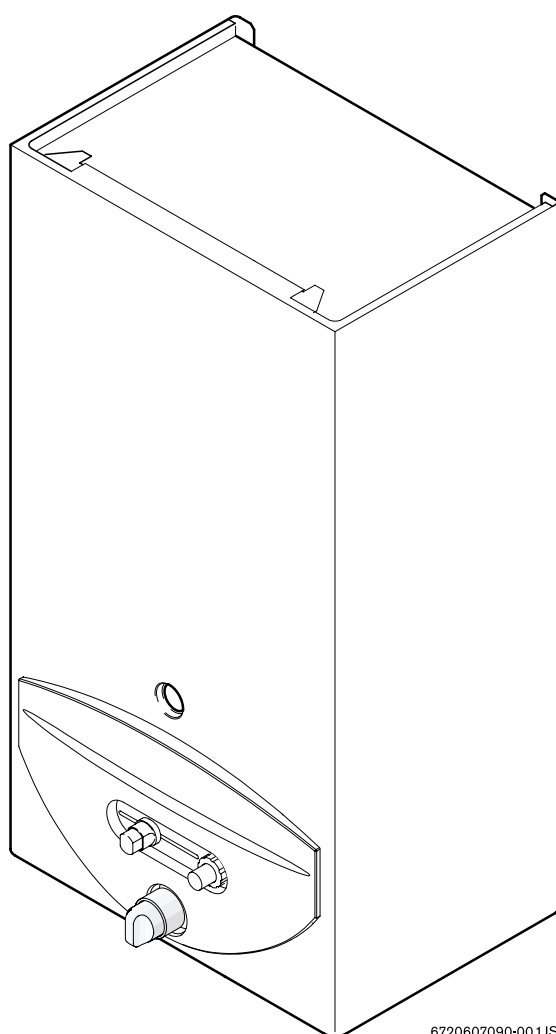

6 720 607 090 (03.12) JS

6720607090-00.1JS

THIS DOCUMENT HAS BEEN PROVIDED BY



heating spares
247.com

PLEASE VISIT WWW.HEATINGSPPARES247.COM FOR FURTHER
INFORMATION AND GENUINE PARTS & SPARES AT LOW PRICES

Natural Gas

Main Multipoint BF
G.C. No 52-467-01



This appliance conforms to European Standard EN 26.

Type test for purpose certified by Notified Body CE-0087.

Product/Production certified by Notified Body CE-0464.
For GB / IE only.

Care must be taken when lifting and handling this appliance, seek assistance where appropriate. Protective equipment (e.g. gloves) should be worn as necessary.

User Information

Your Main Multipoint BF is designed to meet all relevant standards.

Main provide a 12 month guarantee on the appliance. The guarantee operates from the date installation is completed for the customer who is the original owner.

Any component or part which becomes defective during the guarantee period as a result of faulty workmanship or materials whilst in normal use will be repaired or replaced free of charge.

Contents

Section	page
1. User's Operating Instructions	4
2. General Layout	5
3. Technical Data	6
4. Dimensions and Fixings	7
5. General Information	8
6. Installation Regulations	8
7. Siting the Appliance	9
8. Siting the Flue Terminal	10
9. Air Supply	11
10. Gas Supply	11
11. Installation	11
12. Commissioning	13
13. Inspection and Servicing	14
14. Replacement of Parts	16
15. Fault Finding	18
16. Short Parts List	18

1. User's Operating Instructions

Pilot ignition:

1. Depress slide control and hold it in.

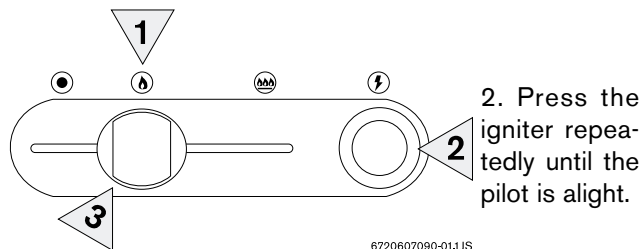

6720607090-01.1JS

3. Release the slide control approx 10 seconds after pilot lights.

4. Repeat these steps if the pilot does not remain alight.

Burner operation:

When the slide control is in the "burner" position the burner will ignite when a hot tap is turned on.

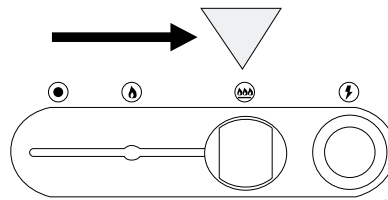

6720607090-02.1JS

Temperature regulation:

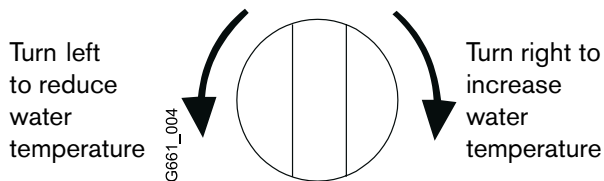

Note: with higher temperatures the available flow of water will be reduced.

Switching off:

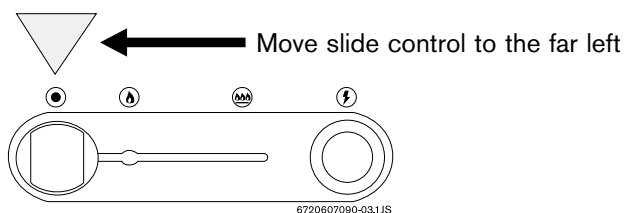

6720607090-03.1JS

Note: the pilot flame will extinguish

Note: if the appliance is to be left unused in an unheated area during cold weather the gas and water supplies should be isolated and the system drained. Your installer will be able to advise you.

- - Off
- 🔥 - Pilot
- 🔥 - Burner
- ⚡ - Igniter

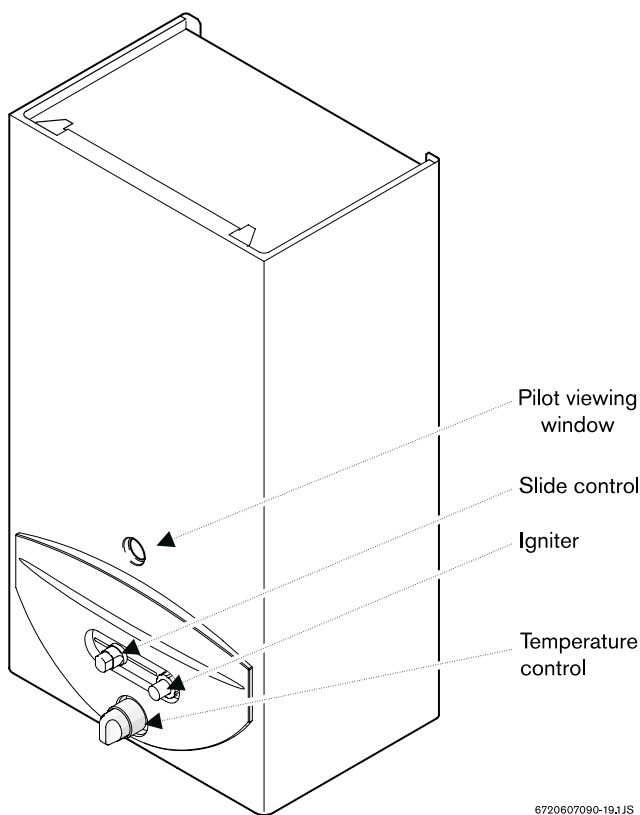

6720607090-19.1JS

2. General Layout

Appliance components

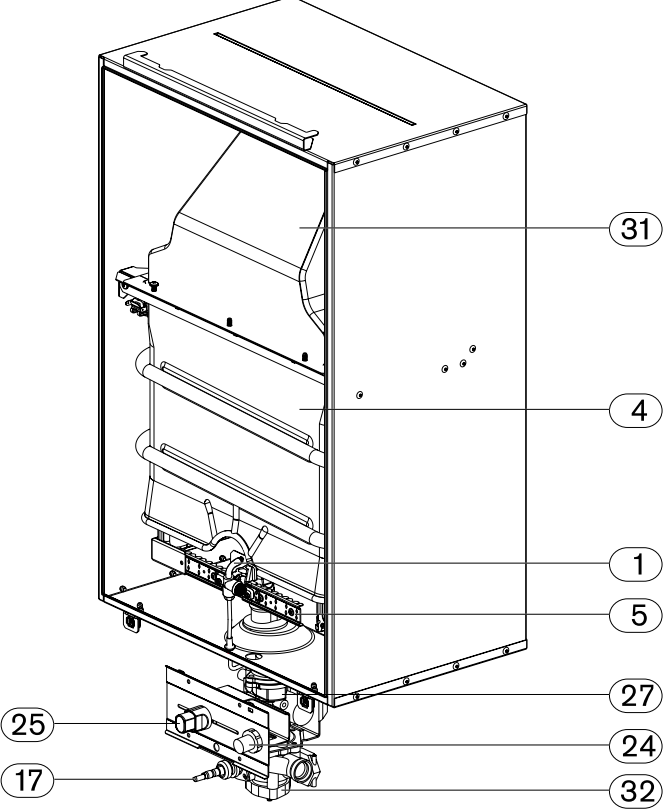

6720607090-021JS
Fig. 3

Appliance water flow diagram.

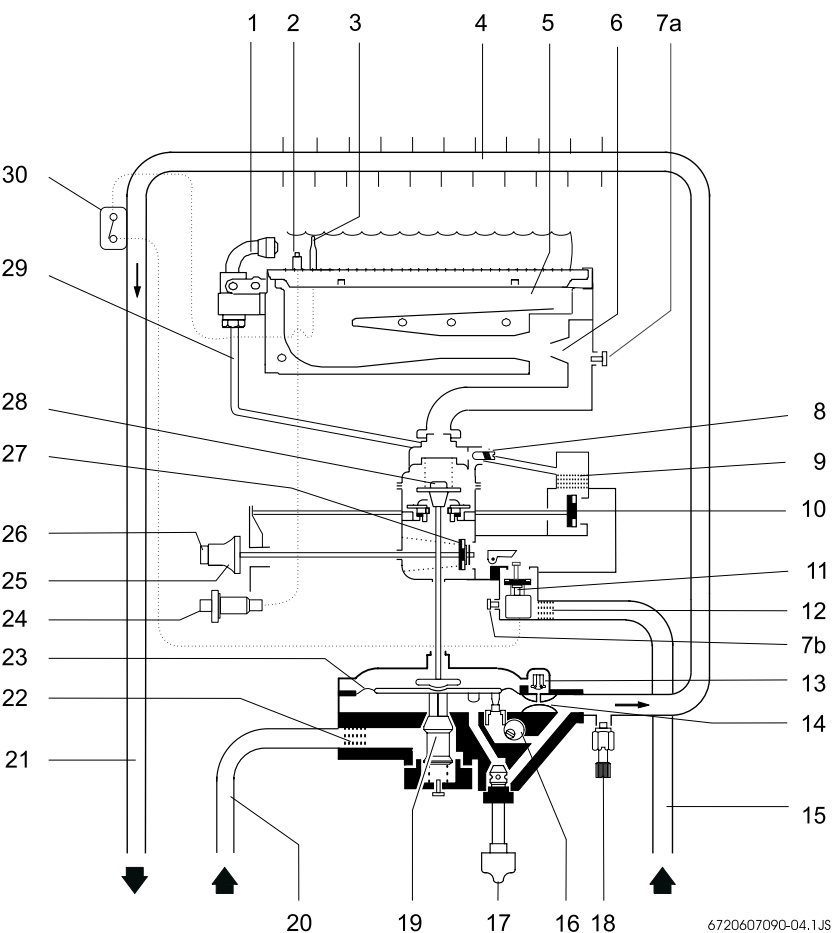

6720607090-04.1JS
Fig. 4

- 1 Pilot burner
- 2 Spark electrode
- 3 Thermocouple
- 4 Heat exchanger
- 5 Main burner
- 6 Burner injector
- 7a Burner pressure test point
- 7b Inlet gas pressure test point
- 8 Gas setting screw
- 9 Pilot gas filter
- 10 Pilot gas valve
- 11 Electromagnetic valve
- 12 Gas filter
- 13 Slow ignition valve
- 14 Venturi
- 15 Gas inlet pipe
- 16 Correcting screw for minimum water flow
- 17 Temperature control
- 18 Drain cock
- 19 Volumetric water governor
- 20 Cold water pipe (inlet)
- 21 Hot water pipe (outlet)
- 22 Water filter
- 23 Diaphragm
- 24 Piezo igniter
- 25 Slide control
- 26 Pilot gas button
- 27 Gas valve
- 28 Main gas valve
- 29 Pilot gas pipe
- 30 Temperature limiter
- 31 Flue hood
- 32 Water valve

3. Technical Data

TABLE 1 - GENERAL

	Natural Gas
Gas category	I _{2H}
Appliance Type	C ₁₁
Minimum rated output	7 kW
Maximum rated output	23 kW
Rated input (Net)	25.5 kW
Gas rate (CV 34 MJ/m ³)	2.9 m ³ /hr
Inlet pressure	20 mbar
Number of injectors	16
Injector diameter	1.05 mm
Pilot injector marking	104
Burner pressure	14.1 mbar
Height	846 mm
Width	420 mm
Depth	285 mm
Dry weight	20 kg
Gas connection	15mm Copper
Hot/cold water connections	15mm Copper

TABLE 2 - FLUE DETAILS

Wall hole size - width		310 mm
Wall hole size - height		300 mm
Sales Code 31/10321	min. length	100 mm (4 in.)
	max. length	150 mm (6 in.)
Sales Code 31/10322	min. length	150 mm (6 in.)
	max. length	230 mm (9 in.)
Sales Code 31/10323	min. length	230 mm (9 in.)
	max. length	380 mm (15 in.)
Sales Code 31/10324	min. length	380 mm (15 in.)
	max. length	610 mm (24 in.)

TABLE 3 - PERFORMANCE

Maximum cold water supply inlet pressure	12 bar (180 p.s.i.)
Minimum cold water supply inlet pressure to operate the appliance	0.2 bar (2.9 p.s.i.)
Minimum cold water supply inlet pressure for maximum domestic hot water flow	1 bar (15 p.s.i.)
Domestic hot water delivery with temperature control knob fully anticlockwise	4 to 13 litres/minute at 25°C temperature rise
Domestic hot water delivery with temperature control knob fully clockwise	2.5 to 6 litres/minute at 55°C temperature rise

The appliance has a permanent pilot.

The appliance and flue components are packed in separate cartons.

The appliance is for use with Natural Gas only.

4. Dimensions and Fixings

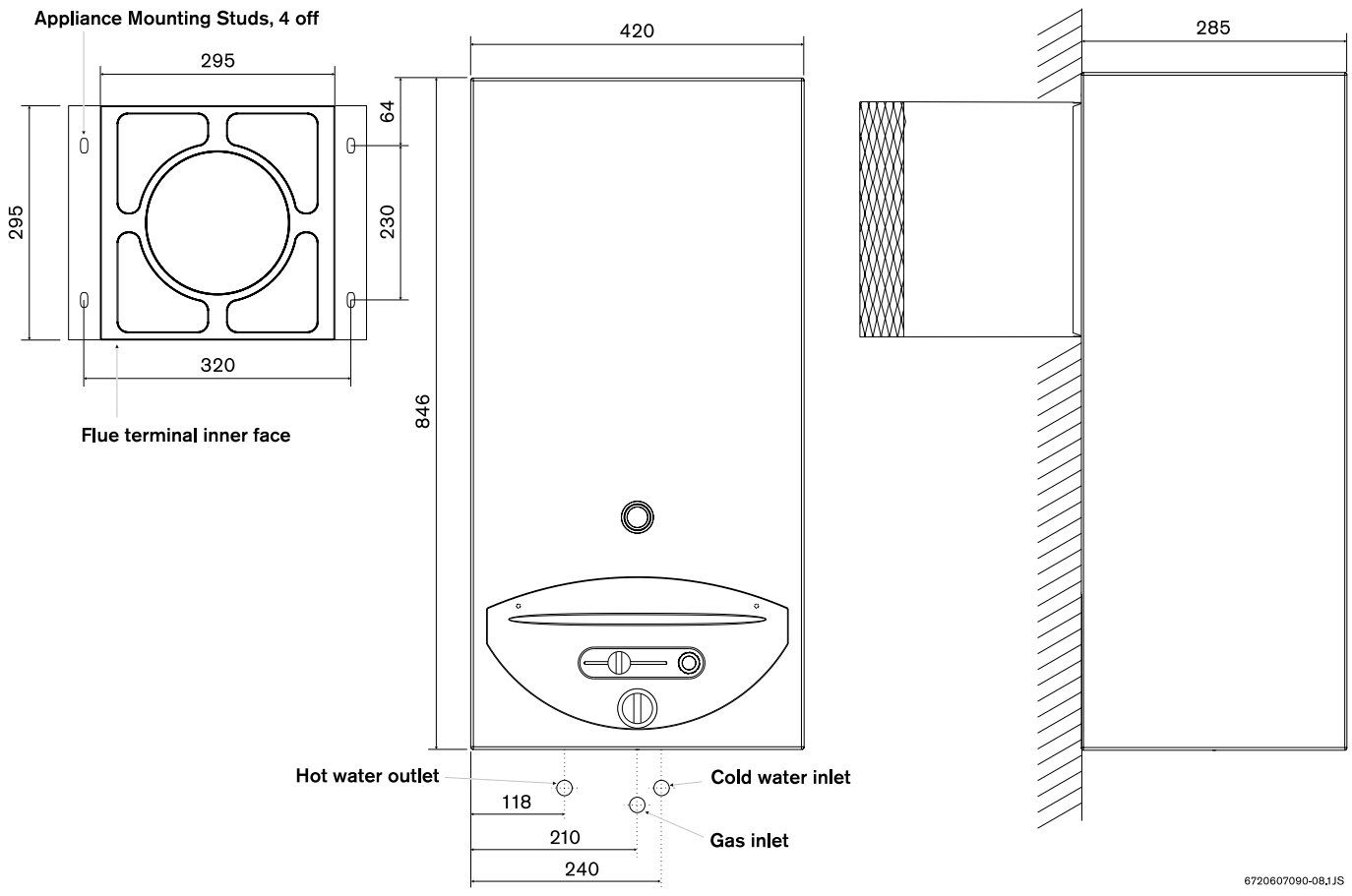

6720607090-08,1JS

Fig. 5

5. General Information

5.1 GENERAL INSTALLATION

If the appliance is to be fitted into a compartment, the compartment must conform to the requirements of BS 6798.

Do not place anything on top of the appliance.

The clearances specified for servicing must be maintained.

5.2 SHOWERS

If a shower control is supplied from the appliance it should be of the thermostatic or pressure balanced type. Thermostatic type shower valves provide the best comfort and guard against water at too high temperature. Existing controls may not be suitable - refer to the shower valve manufacturer.

6. Installation Regulations

6.1 Warning - Check the information on the data plate is compatible with local conditions.

The installation must be carried out by a CORGI Registered Installer or other registered competent person and be in accordance with the relevant requirements of the current Gas Safety (Installation and Use) Regulations, the building regulations (Scotland) (Consolidation), the local building regulations, the current I.E.E Wiring Regulations and by the laws of the local water undertaking.

Where no specific instruction is given, reference should be made to the relevant British Standard Code of Practice. For Ireland, install in accordance with IS 813 "Installation of Gas Appliances".

6.2 B.S Codes of Practice

Standard	Scope
BS 6891	Gas Installation
BS 5546	Installation of water supplies for domestic purposes
BS 6798	Installation of gas fired hot water boilers
BS 5440 Part1	Flues
BS 5440 Part2	Ventilation

WARNING - The addition of anything that may interfere with the normal operation of the appliance without the express written permission of Baxi Potterton could invalidate the appliance warranty and infringe the Gas Safety (Installation and Use) Regulations.

7. Siting the Appliance

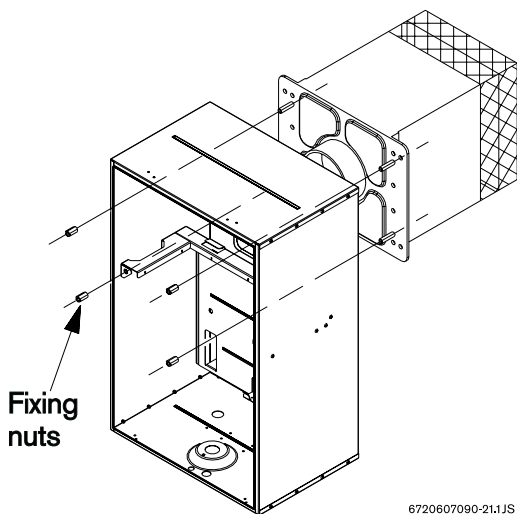

6720607090-21.1JS

Fig. 6

7.1 The appliance is NOT suitable for external installation.

7.2 The appliance is NOT suitable for SEDUCT application.

7.3 The appliance is suitable for replacement onto four stud flue terminals as shown (check dimensions on page 7). The following Appliance Models will have a compatible flue terminal: Severn4/5, Avon, Trent, Thames, Medina/DL, Medway, Bristol and Mersey. It is advisable to examine the condition of the flue and replace if necessary.

7.4 If the appliance is to be fixed to a suitable existing flue terminal (four mounting studs) first isolate and remove the old appliance. Leave the flue terminal in place. Make good any damage to the brickwork or plaster around the terminal. Cut off the existing pipework at a convenient point below the appliance.

7.5 The appliance does not require any special wall protection.

7.6 The wall must be capable of supporting the weight of the appliance. See Technical Data – Table 1.

7.7 If the appliance is to be fitted in a timber framed building, refer to the **Institute of Gas Engineers**, “Guide for gas installations in timber framed housing” **IGE/UP/7**.

7.8 The minimum clearances required for Installation and Servicing:

Above	30 mm
In front	600 mm
Below	75 mm
Right hand side	5 mm
Left hand side	5 mm

7.9 The minimum clearances required for Operation are:

Above	30 mm
In front	60 mm
Below	75 mm
Right hand side	5 mm
Left hand side	5 mm

7.10 The appliance can be installed in a cupboard used for airing clothes provided that requirements of BS 6798 and BS 5440:2 are strictly followed. See section 9 for further detail.

7.11 The airing space must be separated from the appliance space by a perforated non-combustible partition. Expanded metal or rigid wire mesh are acceptable provided that the major dimension is less than 13 mm. See BS 6798.

8. Siting the Flue Terminal

See Fig. 8.

8.1 The flue must be installed as specified in BS 5440:Part 1.

8.2 If the terminal discharges onto a pathway or passageway, check that the combustion products will not cause a nuisance and that the terminal will not cause an obstruction.

8.3 If the terminal is fitted within 850 mm of a plastic or painted gutter or within 450 mm of painted eaves then an aluminium shield at least 750 mm long should be fitted to the underside of the gutter or painted surface.

8.4 If a terminal is fitted less than 2 metres above a surface to which persons have access then a guard must be fitted.

8.5 The terminal guard must be evenly spaced about the flue terminal and fixed to the wall using plated screws.

8.6 Under certain weather conditions the terminal may plume when the appliance is operated. Siting where this could cause a nuisance should be avoided.

8.7 Take care to ensure that combustion products do not enter ventilated roof voids by positioning the flue away from any soffit vents.

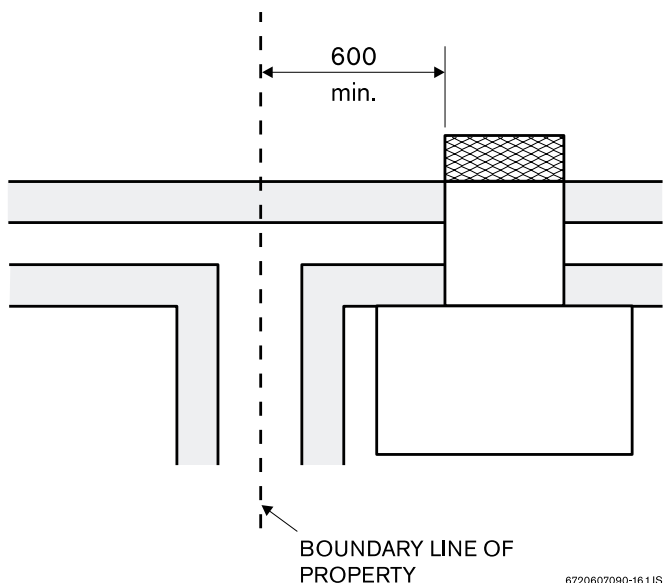
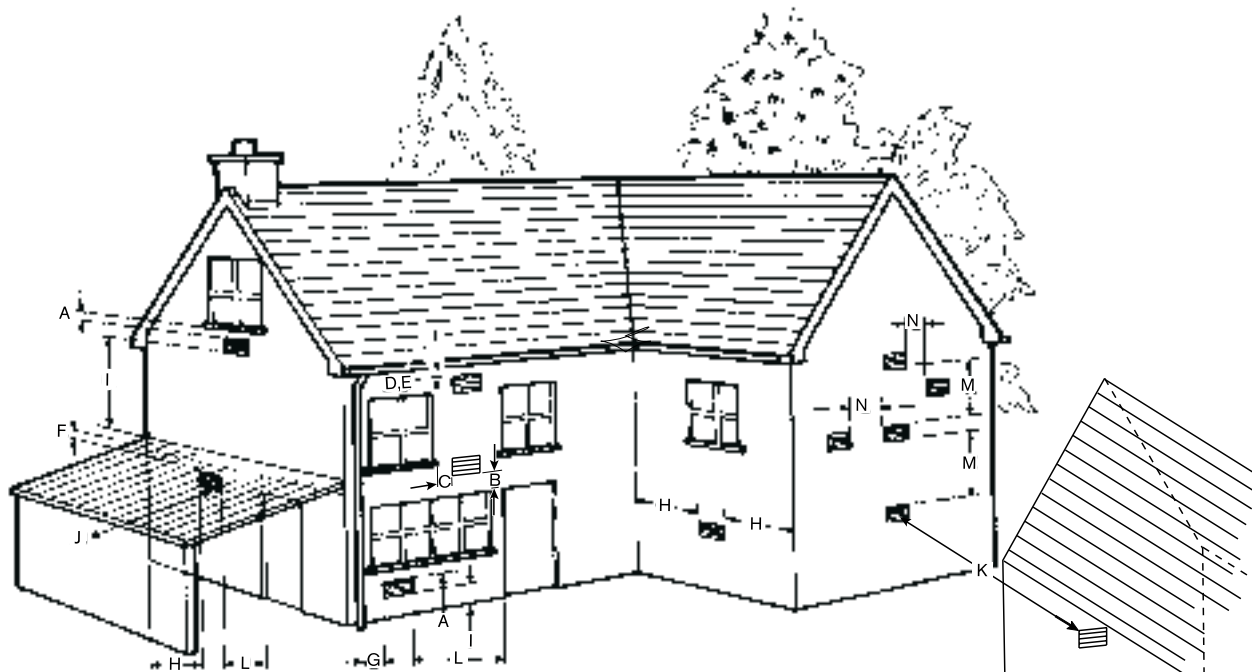

Fig. 7



Dimension	Terminal position	Minimum distance
A ^a	Directly below an opening, air brick, opening windows, etc.	1500 mm
B ^a	Above an opening, air brick, opening window, etc.	300 mm
C ^a	Horizontally to an opening, air brick, opening window, etc.	600 mm
D	Below gutters, soil pipes or drain pipes	300 mm
E	Below eaves	300 mm
F	Below balconies or car port roof	600 mm
G	From a vertical drain pipe or soil pipe	300 mm
H	From an internal or external corner	600 mm
I	Above ground roof or balcony level	300 mm
J	From a surface facing the terminal	600 mm
K	From a terminal facing the terminal	600 mm
L	From an opening in the car port (e.g. door, window) into the dwelling	1 200 mm
M	Vertically from a terminal on the same wall	1 500 mm
N	Horizontally from a terminal on the same wall	300 mm

Fig. 8 - Siting of the flue terminal

9. Air Supply

9.1 The appliance does not require a separate vent for combustion air.

9.2 The appliance may be installed in an unvented compartment.

9.3 There must be sufficient clearance around the appliance to allow proper circulation of air. The clearances required for operation will normally be adequate.

9.4 Refer to BS 6798 and BS5440:2 for additional information.

10. Gas Supply

10.1 The gas installation should be in accordance with BS 6891.

10.2 The connection to the appliance is 15mm compression via the gas isolation valve supplied.

10.3 Ensure that the pipework from the meter to the appliance is of adequate size. If the appliance gas rate cannot be achieved, the specified hot water conditions will not be reached.

11. Installation

11.1 FLUE INSTALLATION

If an existing flue terminal is not being used, refer to the flue installation instructions on the wall template.

11.2 Unpack the appliance and take care to remove the installation kit which is packed on top of the polystyrene packing

The installation kit consists of the following:

Gas inlet:

1x Copper inlet elbow, Compression Nut, fibre washer
1x Isolation valve, 2 x Compression nuts and Olives

Water Inlet:

1x Copper inlet elbow, Compression Nut, fibre washer
1x Isolation valve, 2 x Compression nuts and Olives

Water Outlet:

1x Flanged Copper Pipe, Compression nut, Fibre washer

11.3 Lay the appliance on its back and unscrew the Temperature Control Knob Bezel.

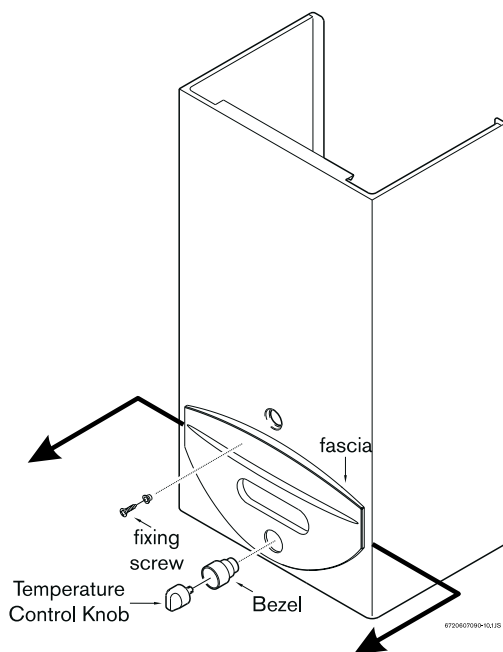
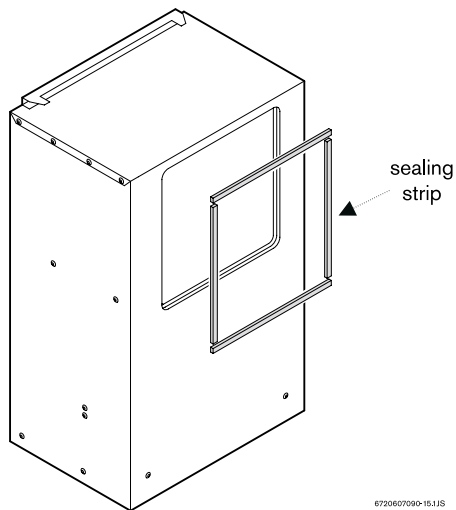

Fig. 9



6720607090-15.1JS

Fig. 10

- 11.4 Unfasten the two retaining screws and lift the case clear.
- 11.5 Remove the flue hood from the appliance by undoing the three fixing screws and lift the hood clear.
- 11.6 Place the appliance on its side, obtain the flue terminal sealing strip from the kit and fit into the recess around the flue aperture in the back of the appliance. (fig. 10).
- 11.7 Lift the appliance and locate onto the four flue terminal mounting studs. Secure in position using the four slotted nuts and washers provided.
- 11.8 Re-fit the flue hood making sure that the spigot of the collector hood enters the flue terminal duct. Tighten the three collector hood fixing screws.

Note: The whole of the gas installation should be inspected and tested for soundness and purged in accordance with the recommendations of BS 6891.

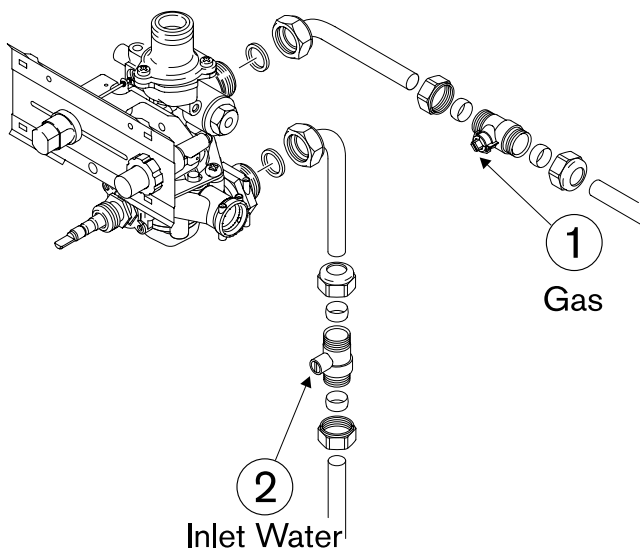

6720607090-18.1JS

Fig. 11

- 11.9 Make up the gas supply to the upper connection on the gas control assembly using the fibre washer provided. Fit the gas isolation valve as close as possible to the appliance (fig. 11, pos. 1).
- 11.10 Connect the appliance to the incoming cold water supply using the copper Inlet Elbow and Isolation Valve. A fibre washer is provided (fig. 11, pos. 2).
- 11.11 Connect the appliance to the domestic water remote draw off points via the outlet fitting.
- 11.12 Turn on the water supply to the appliance. Open the isolation valve on the inlet fitting to the appliance and then open the highest hot water tap in the installation until all air is removed from the system.

12. Commissioning

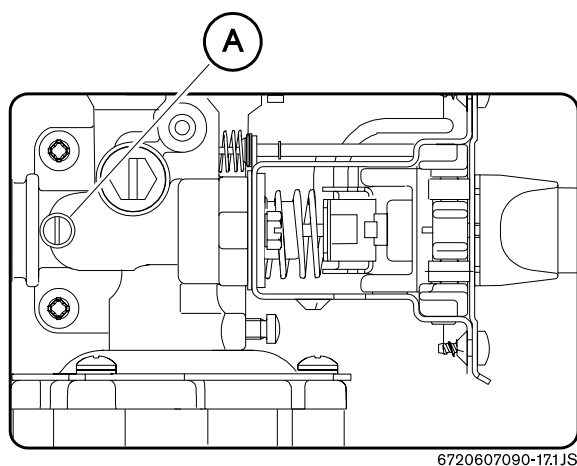

Fig. 12 - Inlet pressure test point

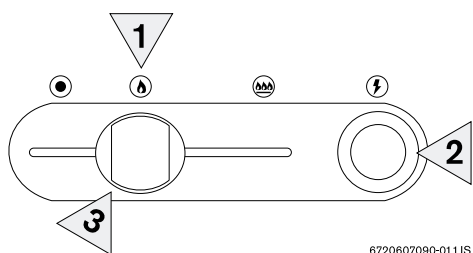

Fig. 13 - Gas control slide - Pilot ignition position

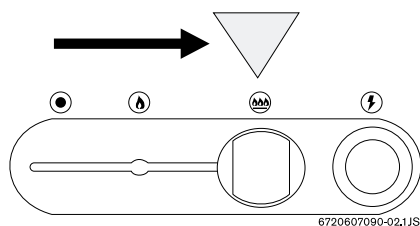

Fig. 14 - Gas control slide - operating position

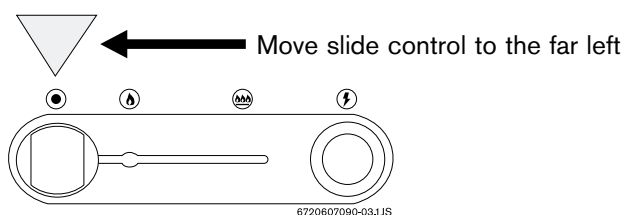

Fig. 15 - Gas control slide - shut down position

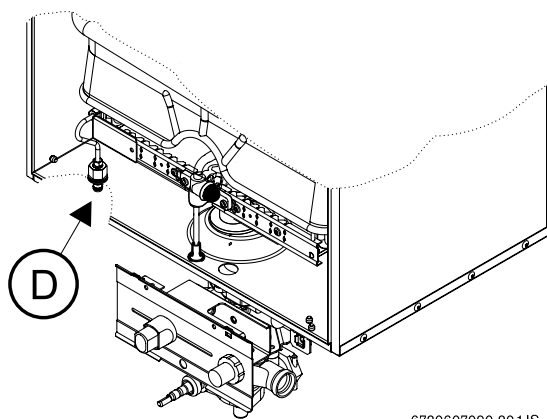

Fig. 16 - Burner pressure test point

Before commissioning the appliance, the gas installation must be purged and tested for gas soundness in accordance with BS 6891.

- 12.1 Ensure that the gas isolation valve in the gas inlet pipe is turned off.
- 12.2 Loosen screw A and connect a pressure gauge to the test point. (fig. 12).
- 12.3 Turn on the gas isolation valve, replace the Outer Case.
- 12.4 Move the gas control slide to the ignition position (1). (fig. 13).

Depress slide control and hold it in.

Press the igniter (f) repeatedly until the pilot is alight.

Release the slide control approx 10 seconds after pilot lights.

Repeat these steps if the pilot does not remain alight.

Note: On initial light up, or after prolonged shut down, the establishment of the pilot may take several attempts due to the presence of air in the gas supply pipe.

The pilot flame should envelope approximately 5 mm of the thermocouple head.

- 12.5 Once pilot is established, move slide control to burner operation position (2). Fully open any hot water tap. The main burner should light.

- 12.6 Check the dynamic inlet gas pressure is 20 mbar. If the pressure is not correct then check the gas supply to the appliance.

If the pressure is correct, turn off the hot water tap and move the slide to the off position. (fig. 15).

Remove the outer Case, turn off the Gas Isolation Valve. Remove the pressure gauge and tighten screw A. (fig. 12).

- 12.7 The burner pressure is factory set and should not require adjustment, confirmation of burner pressure can be made as below.

Loosen screw D and connect the pressure gauge to the test point (fig. 16). Replace the Outer Case.

Re-light the appliance as described in paragraph 12.4 and 12.5.

- 12.8 Operate the appliance for at least 2 minutes then check that the burner pressure is 14.1 mbar.

- 12.9 Turn off the hot water tap. remove the Outer Case. Close the gas service cock. Remove the pressure gauge and tighten screw D. Replace the Outer Case.

- 12.10 On completion of the commissioning and testing of the system, the installer should:

12.10.1 Give the Instructions to the user for safe keeping.

12.10.2 Explain and demonstrate the lighting and shutdown procedures.

12.10.3 Advise the user of the precautions necessary to prevent damage to the system and to the building in the event of the system remaining inoperative during frost conditions.

12.10.4 Recommend that the appliance is serviced annually for reasons of safety and economy and that the servicing must be carried out by a competent person.

13. Inspection and Servicing

For reasons of safety and economy it is recommend that the appliance is serviced annually. The servicing must be carried out by a competent person.
 Before commencing any service operation turn off the gas supply at the main gas service cock. Ensure that the appliance is cool.

Access for Servicing

- Pull off the fascia and undo the two fixing screws.
- Pull off the Temperature Control Knob.
- Unscrew Temperature Control Knob Bezel.
- Lift the casing clear. (See fig. 17).

13.1 Heat Exchanger

- Remove the flue hood assembly by undoing the three retaining screws and pulling the hood out of the flue connector duct.
- Inspect and if necessary clean the heat exchanger flueways.

13.2 Pilot Assembly

- Undo the nuts at both ends of the pilot pipe. Withdraw the pilot pipe downward taking care to retain the pilot injector.
- Inspect the pilot injector.
- Check the pilot burner and electrode are clean and undamaged.
- Pull off the pilot filter and clean. (fig. 18).
- Clean or replace components if necessary.

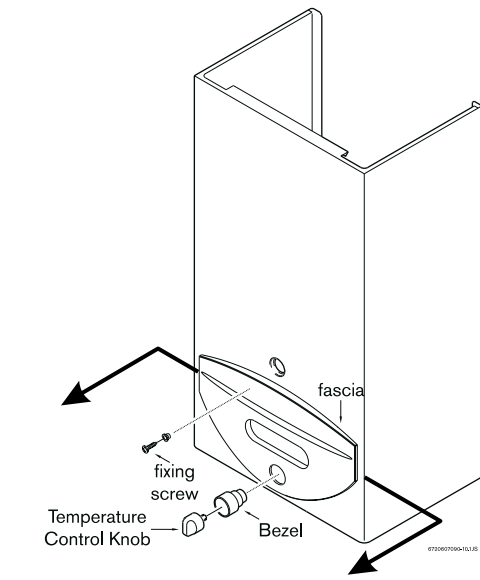

Fig. 17 - Access for servicing

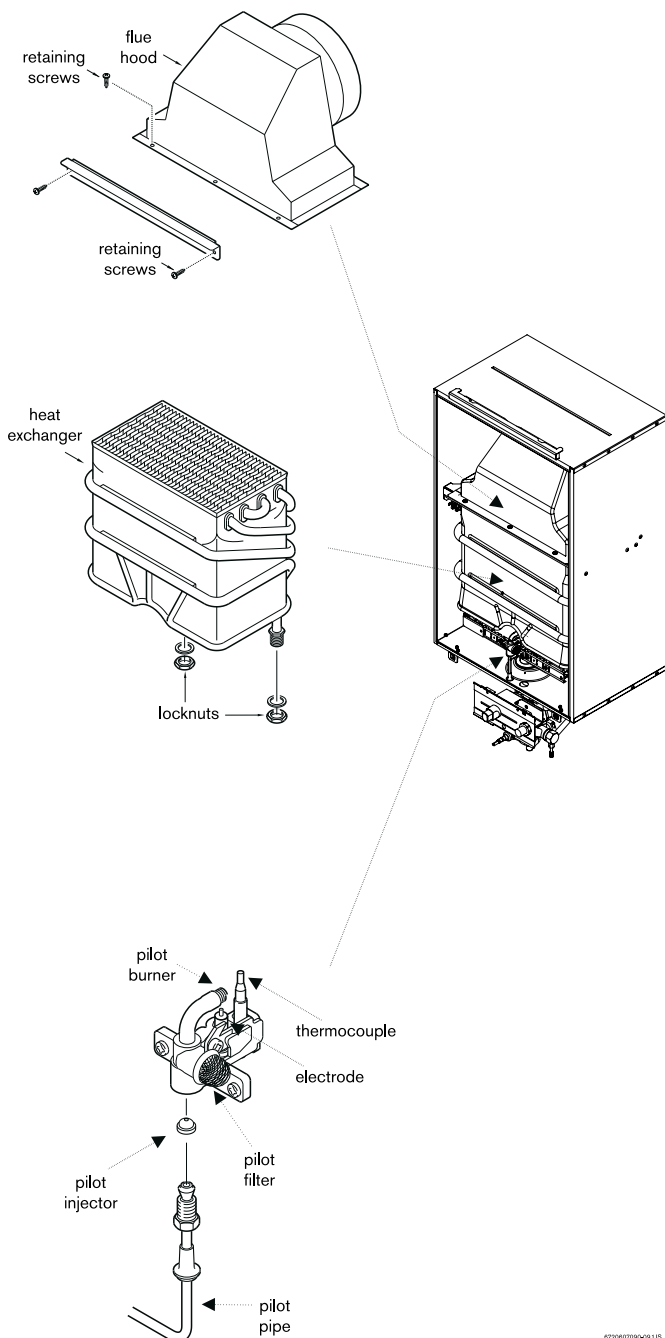

Fig. 18

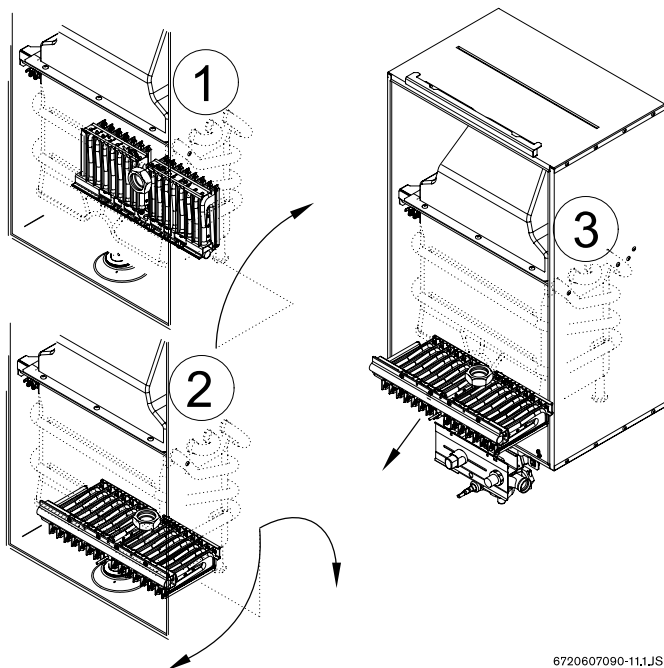

Fig. 19

13.3 Main Burner

Disconnect the pilot gas pipe at the gas valve.
 Disconnect the pilot gas pipe from the pilot burner and remove from the appliance complete with seal. Take care not to lose the pilot injector.
 Remove the two screws retaining the pilot bracket and lift complete assembly clear.
 Disconnect the union fittings at either end of the pressure test pipe located to the left hand side of the burner.
 Remove and retain the fibre washer.
 Remove the pressure test pipe.
 Lift and rotate the front edge of the burner backward through 180 degrees. With the burner oriented horizontally and upside down, withdraw forward beneath the combustion chamber skirt. (fig. 19).
 Inspect and clean the injectors if necessary.
 Inspect and clean the main burner bars if necessary.

13.4 Re-assembling the Appliance

Re-assemble the appliance in reverse order ensuring the following:

1. The flue hood outlet duct correctly enters the flue terminal duct and the flue hood is fully seated against the top of the heat exchanger.
2. The washer in the main gas line union connection is correctly located.
3. The seals around the igniter cable/thermocouple and pilot gas pipe are correctly seated in the combustion chamber base and the pilot injector has been fitted. (fig. 20).

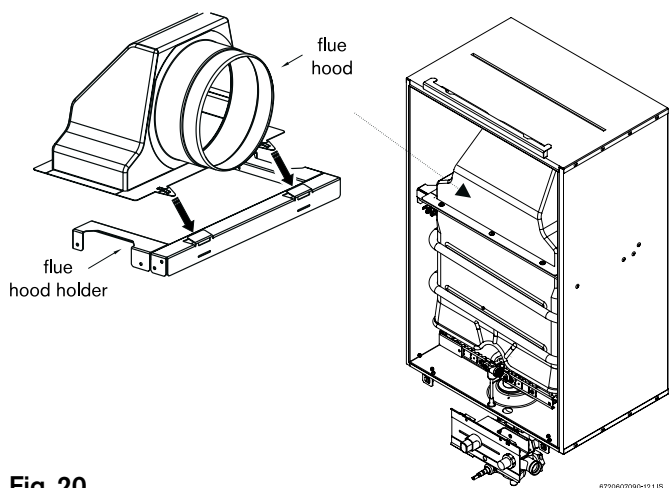

Fig. 20

Turn on the gas supply at the main gas service cock and check for gas soundness BS 6891 while the appliance is running.

Re-commission the appliance as detailed in Section 12.

14. Replacement of Parts

Any servicing or parts replacement must be carried out by a competent person. Use only genuine Manufacturer's Parts. Before commencing servicing or parts replacement turn off the gas supply at the main gas isolation valve and ensure that the appliance is cool.

14.1 Pilot Burner / Injector

Disconnect the pilot gas pipe and thermocouple at the gas valve and pull off the red cable from the igniter unit. Disconnect the pilot gas pipe from the pilot burner and remove from the appliance complete with seal. Take care not to lose the pilot injector. inspect and replace the injector if necessary.

Remove the two screws retaining the pilot bracket and lift the complete assembly clear complete with the red seal.

Pull off the pilot filter. Undo the screw fixing the spark electrode/ thermocouple retaining bar and lift these clear. Replace the pilot burner/bracket and re-assemble in reverse order. (fig. 21).

14.2 Spark Electrode / Thermocouple

Follow the instructions in Section 14.1 and replace the faulty component.

14.3 Main Burner

Disconnect the pilot gas pipe and thermocouple at the gas valve and pull off the red cable from the igniter unit. Disconnect the pilot gas pipe from the pilot burner and remove from the appliance with seal. Take care not to lose the pilot injector.

Remove the two screws retaining the pilot bracket and lift the complete assembly clear.

Disconnect the union fittings at either end of the pressure test pipe located to the left hand side of the burner.

Undo the union connection below the burner.

Remove and retain the fibre washer.

Remove the pressure test pipe.

Lift and rotate the front edge of the burner backward through 180 degrees. With the burner oriented horizontally and upside down, withdraw forward beneath the combustion chamber skirt.

Replace the burner and re-assemble in reverse order taking care that the seals around the igniter cable/ thermocouple and pilot gas pipe are correctly seated in the combustion chamber base and the pilot injector has been fitted. (fig. 21 and 19).

14.4 Heat Exchanger

Remove the flue hood assembly by undoing the three retaining screws and pulling the hood out of the flue terminal duct.

Isolate the appliance from the incoming cold water supply, open a hot tap and drain down the appliance via the fitted drain cock.

Undo the two retaining screws from the heat exchanger bracket.

Disconnect the heat exchanger inlet and flow pipes at the base of the combustion chamber.

Remove the locknuts from the heat exchanger inlet and

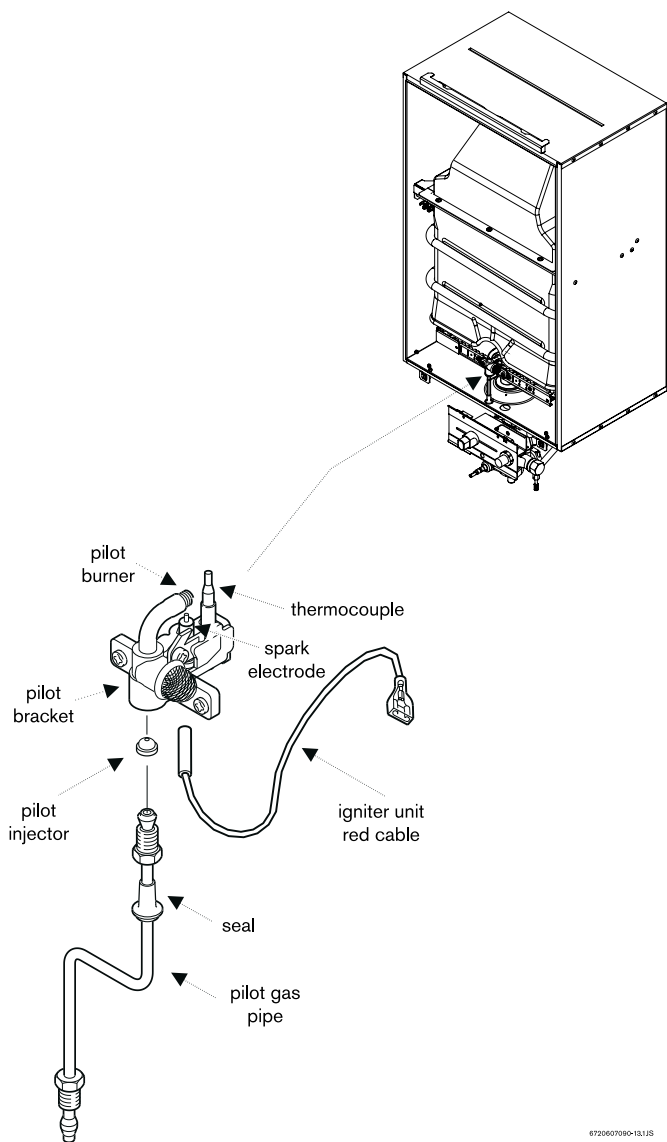

6720607990-131JS

Fig. 21

outlet connections and lift the heat exchanger clear. Replace the heat exchanger and re-assemble in reverse order.

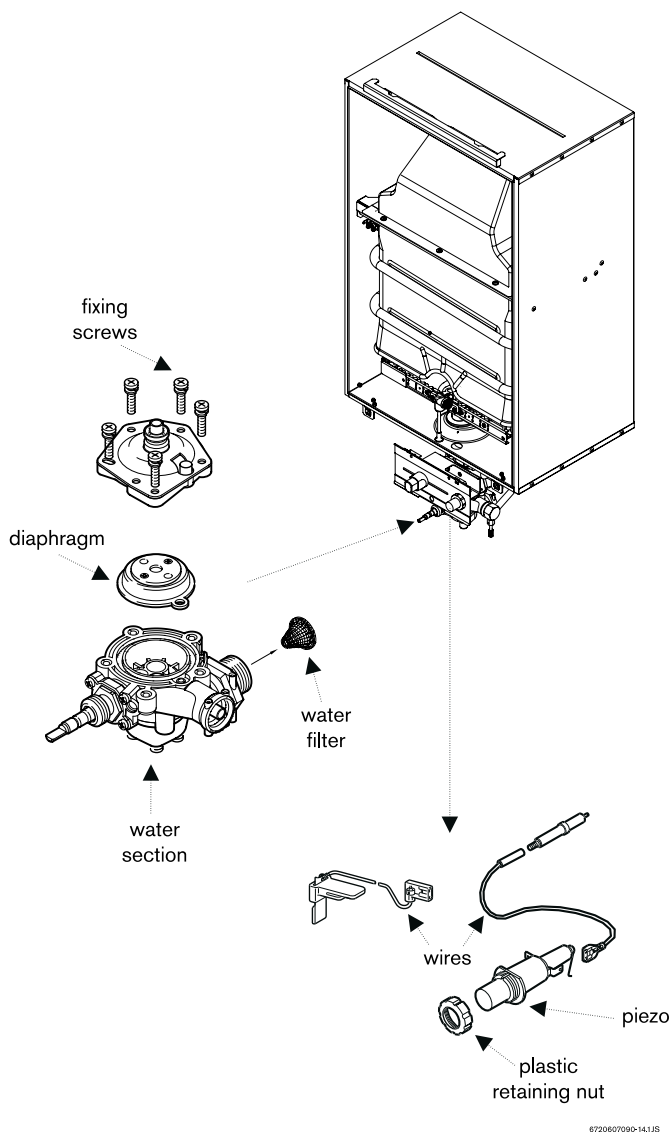

6720607090-14.1JS
Fig. 22

14.5 Igniter Unit

Pull off the two wires from the rear of the unit, unscrew the plastic retaining nut on the control panel and push out the Piezo unit. Replace and re-assemble in reverse order. (fig. 22).

14.6 Water Valve

Isolate the appliance from the incoming cold water supply and drain down the appliance via the fitted drain cock. Undo the inlet water connection at the base of the combustion chamber and at the water valve inlet. Slacken the two screws between the water valve and gas valve and pull the water valve clear. The diaphragm within the valve can be replaced by removing the five fixing screws holding the valve body together. Pull out the water filter fitted into the incoming cold water tapping. Clean or replace as necessary. Re-assemble in reverse in order. (fig. 22).

14.7 Gas Valve

Remove the water valve as described in Section 14.6. Disconnect the pilot gas pipe and thermocouple from the gas valve. Pull off the two cables from the rear of the igniter unit. Release the main gas pipe union connection below the combustion chamber and lift the valve clear complete with the control panel. Remove the Piezo unit as described in Section 14.5. Remove the control facia by taking out the four fixing screws and lifting clear complete with slider knob. Prise out the slider bar and remove the two screws retaining the control frame and lift clear. Replace the gas valve and re-assemble in reverse order.

15. Fault Finding

Problem	Cause	Solution
Incorrect water temperature.	Incorrect gas rate.	Check the gas supply to appliance gas isolation valve. Open the gas isolation valve. Check the burner pressure. Check the inlet pressure.
	Water section sticking or faulty.	Clean or replace.
Incorrect water flow rate.	Incoming supply valve closed.	Open supply valve.
	Low water pressure.	Check the water pressure is above 0.2 bar.
	Water section sticking or faulty.	Clean or replace.
Noise.	Scale in heat exchanger.	Descale and service.
	High gas rate.	Check the burner pressure.
	Low water flow rate.	Check the water flow rate.
Pilot flame will not light or stay lit.	No gas supply.	Connect gas supply.
	Gas isolation valve closed.	Open gas isolation valve.
	Air in gas line.	Purge the line.
	Pilot injector blocked.	Clean/replace the injector.
	No spark.	Clean or replace the electrode, Piezo unit or cable.
Main burner will not light.	Gas pressure low.	Check the inlet and burner pressure.
	Gas isolation valve partially closed.	Open the gas isolation valve.
	Low water rate.	Check the water rate.
	Water section diaphragm faulty.	Replace the diaphragm.
	Gas valve faulty.	Replace the gas valve.
Explosive ignition.	Reduced pilot flame.	Clean or replace the pilot injector assembly.
	Faulty slow ignition valve.	Replace the slow ignition valve.

16. Short Parts List

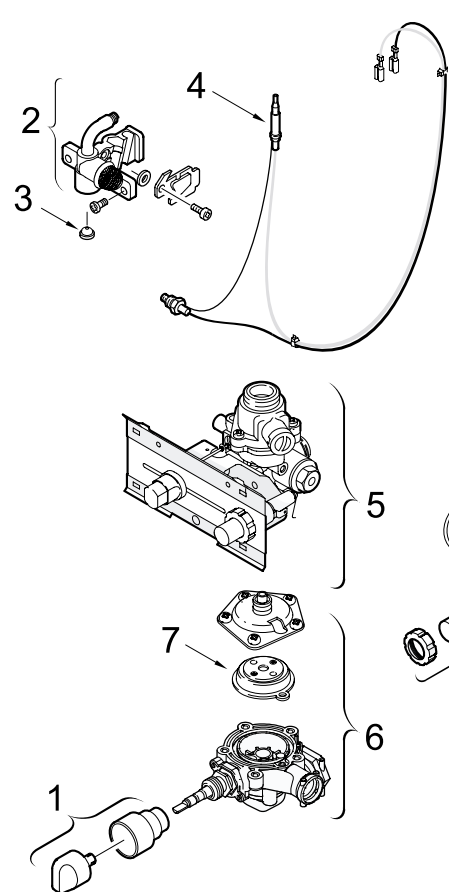

	Description	Part Number
1	Knob and Bezel	5 110 844
2	Pilot Burner (75)	5 110 880
3	Pilot Injector (5)	5 110 884
4	Thermocouple	5 110 886
5	Gas Valve	5 110 894
6	Water valve	5 110 959
7	Diaphragm (F)	5 110 963
8	Piezo Igniter	5 110 953
9	Spark Electrode	5 110 956

6720607090-22.1JS

Fig. 23

GENERAL ENQUIRIES (GB)

08706 060 780

TECHNICAL (GB)

08706 049 049

SERVICE (GB)

08706 096 096

LITERATURE REQUEST (GB)

08706 060 623

TECHNICAL (IE)

1850 560 570

MAIN

Baxi Potterton
A Trading Division of Baxi Heating U.K. Ltd
Brownedge Road Bamber Bridge Preston Lancashire PR5 6SN