

# Baxi Maxflow Combi WM

Please leave these instructions with the user

## Gas fired Wall Mounted Combination Boiler with Unvented Hot Water storage

Comp N° 247308 - Iss 3 – 6/00

### Installation and Servicing Instructions

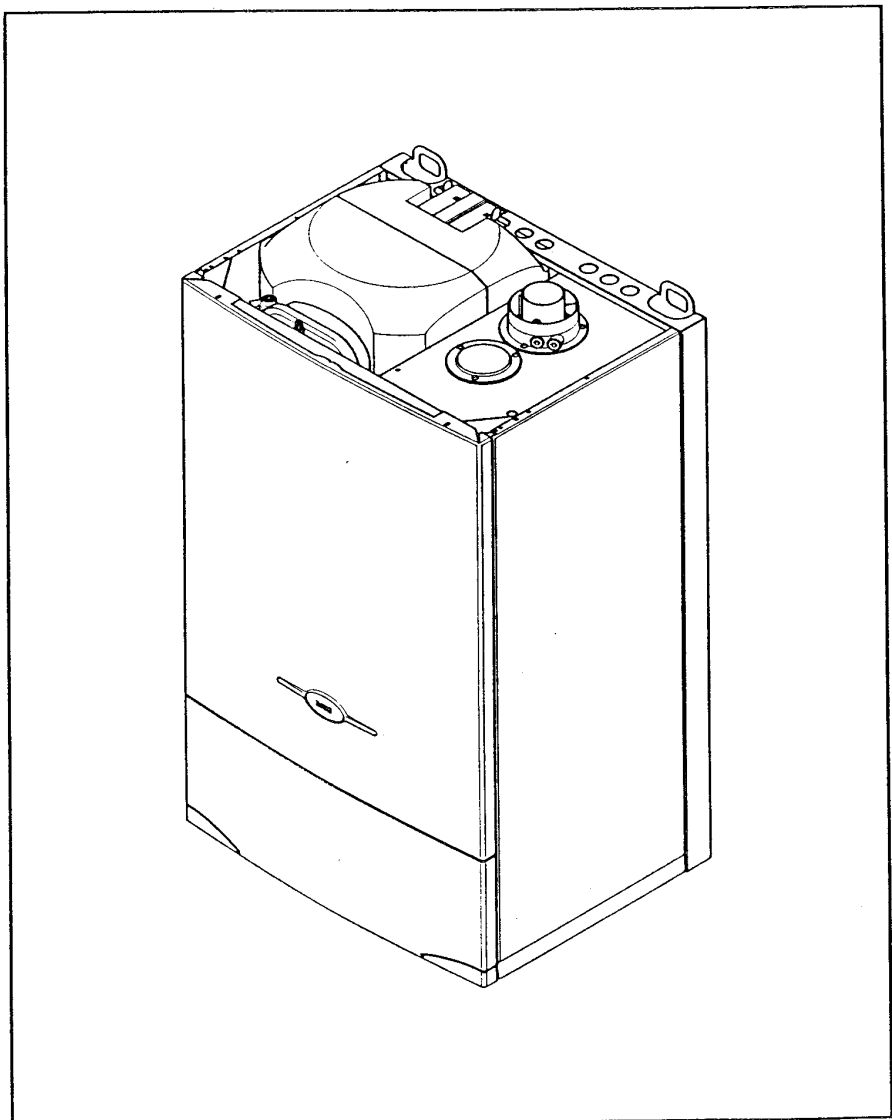

THIS DOCUMENT HAS BEEN PROVIDED BY  
**heatingspares247.com**  
PLEASE VISIT [WWW.HEATINGSPPARES247.COM](http://WWW.HEATINGSPPARES247.COM) FOR FURTHER INFORMATION AND GENUINE PARTS & SPARES AT LOW PRICES

# BAXI

**Baxi Maxflow Combi WM**  
G.C. N° 47 075 03

Baxi Limited is one of the leading manufacturers of domestic heating products in the UK.

Our first priority is to give a high quality service to our customers. Quality is built into every Baxi product -products which fulfil the demands and needs of customers, offering choice, efficiency and reliability.

To keep ahead of changing trends, we have made a commitment to develop new ideas using the latest technology - with the aim of continuing to make the products that customers want to buy.

Baxi is also the largest manufacturing partnership in the country. Everyone who works at the company has a commitment to quality because, as shareholders, we know that satisfied customers mean continued success.

We hope you get a satisfactory service from Baxi. If not, please let us know.

The boiler meets the requirements of Statutory Instrument "The Boiler (Efficiency) Regulations 1993 N° 3083" and is deemed to meet the requirements of Directive 92/42/EEC on the energy efficiency requirements for new hot water boilers fired with liquid or gaseous fuels:-

Type test for purpose of Regulation 5 certified by:  
Notified Body 0051.

Product/Production certified by:  
Notified Body 0051.

For GB/IE only.



Baxi is a BS-EN ISO 9001  
Accredited Company

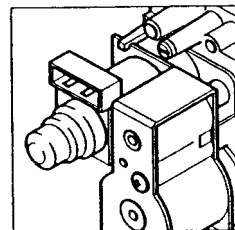
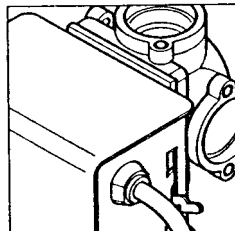
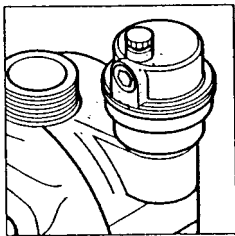

<b>Section</b>		<b>Page</b>
1.0	<b>Introduction</b>	4
2.0	<b>General Layout</b>	5
3.0	<b>Appliance Operation</b>	6
4.0	<b>Technical Data</b>	7
5.0	<b>Dimensions and Fixings</b>	8
6.0	<b>System Details</b>	9
7.0	<b>Site Requirements</b>	13
8.0	<b>Installation</b>	18
9.0	<b>Commissioning the Boiler</b>	23
10.0	<b>Servicing the Boiler</b>	25
11.0	<b>Changing Components</b>	27
12.0	<b>Illustrated Wiring Diagram</b>	36
13.0	<b>Fault Finding</b>	38
14.0	<b>Short Parts List</b>	42

**NOTE:** This appliance must be installed in accordance with the manufacturer's instructions and the regulations in force. Read the instructions fully before installing or using the appliance.

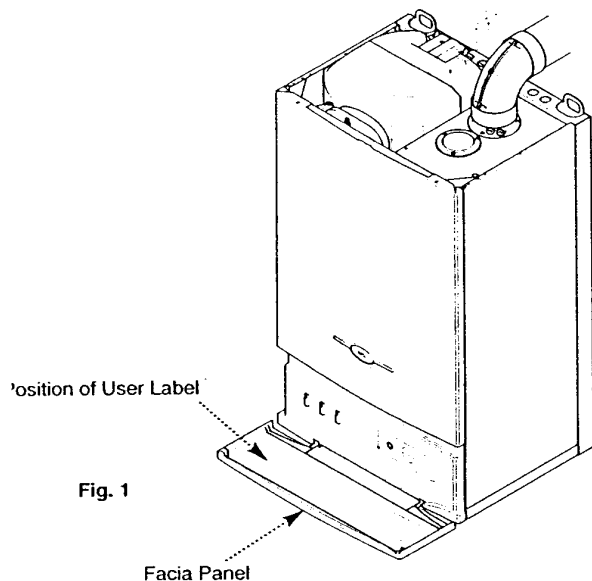

Fig. 1

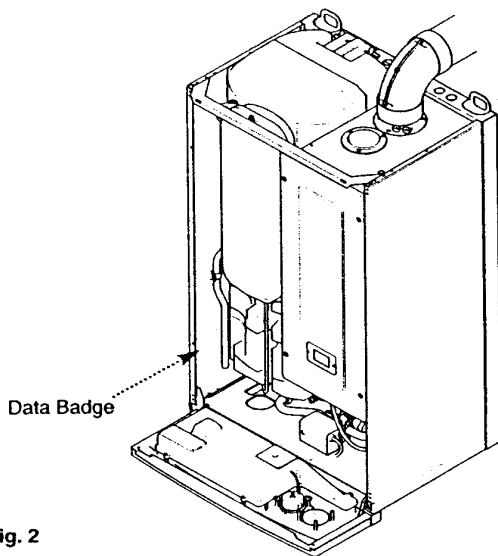

Fig. 2

**“Benchmark” Log Book**

As part of the industry-wide “Benchmark” initiative all Baxi boilers now include an Installation, Commissioning and Service Record Log Book. Please read the Log Book carefully and complete all sections relevant to the appliance and installation. These include sections on the type of controls employed, flushing the system, burner operating pressure etc. The details of the Log Book will be required in the event of any warranty work. Also, there is a section to be completed at each subsequent regular service visit.

**Baxi UK Limited declare that no substances harmful to health are contained in the appliance or used during appliance manufacture.**

**1.1 Description**

1. The Baxi Maxflow Combi WM is a fully automatic gas fired wall mounted combination boiler incorporating a 54 litre unvented hot water storage cylinder. It is room sealed and fan assisted.
2. The boiler is designed for use with a fully pumped, sealed and pressurised system and provides central heating and hot water at mains pressure. It incorporates a pump, diverter valve, pressure relief valve, expansion vessel and pressure gauge.
3. As supplied the boiler will automatically modulate to provide a central heating output between 10.4kW and 28.0 kW. The maximum output to central heating can be adjusted between 10.4 kW and 28.0 kW (see Section 9.2). The maximum output available for domestic hot water is 28.0 kW.
4. The boiler has been approved to the Building Regulations for unvented hot water storage systems and the Local Authority must be informed of the intention to install.

**IMPORTANT: The installation of unvented hot water storage systems and their components must only be carried out by suitably qualified personnel. Consideration should be given to Building Regulations document G3.**

5. The components supplied in the box marked ‘Unvented Kit’ **MUST** be fitted to the mains water supply in accordance with the instructions included.
6. It is designed for use on Natural Gas (G20) and can be converted to use Propane or Butane.
7. A label giving details of the model, serial number and Gas Council number is situated on the rear of the fascia panel (Fig. 1).
8. The boiler data badge is positioned inside the left hand outercase panel (Fig. 2).
9. The boiler is intended to be installed in residential / commercial / light industrial E.M.C. environments on a governed meter supply only.
10. The boiler must be installed with one of the purpose designed flues such as the standard horizontal flue kit.
11. **All systems must be thoroughly flushed and treated with Inhibitor (see section 6.2).**

**1.2 Installation**

1. The appliance is suitable for installation only in G.B. and I.E. and should be installed in accordance with the rules in force. For Ireland install in accordance with I.S.813 “Installation of Gas Appliances”. The installation must be carried out by a CORGI Registered Installer or other competent person and be in accordance with the relevant requirements of current Gas Safety (Installation and Use) Regulations, the Building Regulations (Scotland) (Consolidation), the Local Building Regulations, the Current I.E.E. Wiring Regulations and the bye laws of the Local Water Undertaking. Where no specific instructions are given, reference should be made to the relevant BRITISH STANDARD CODES OF PRACTICE.

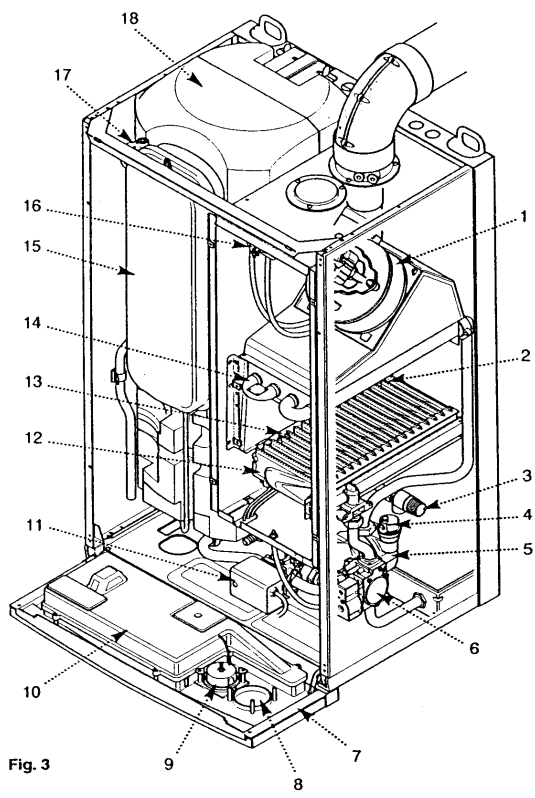
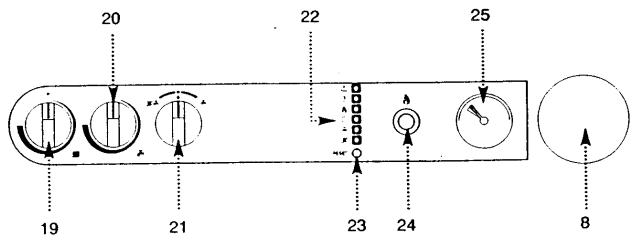

Fig. 3



**2.1 Layout**

- 1 Fan Assembly
- 2 Sensing Electrode
- 3 Pressure Relief Valve
- 4 Automatic Air Vent
- 5 Circulation Pump
- 6 Gas Valve Assembly
- 7 Facia and Control Panel
- 8 Optional Integral Timer
- 9 Pressure Gauge
- 10 Electrical Box
- 11 Motorised Valve
- 12 Burner
- 13 Spark Electrodes
- 14 Heat Exchanger
- 15 Expansion Vessel
- 16 Air Pressure Switch
- 17 Cylinder Safety Valve
- 18 Hot Water Storage Cylinder
- 19 Central Heating Temperature Control
- 20 Domestic Hot Water Temperature Control
- 21 ON/OFF Selector Switch
- 22 Indicator Neons
- 23 Reset Button
- 24 Flame Failure Reset Button
- 25 Pressure Gauge

**2.2 Optional Extras**

KIT	PART N°
<b>HORIZONTAL FLUE KITS</b>	
1M Flue Extension (use two kits for 2M etc.)	247723
0.5 M Flue Extension	247724
Flue Bend - 45° (Reduce overall length of flue by 0.5m when fitting this bend)	247725
Flue Bend . 90° (Reduce overall length of flue by 1 m when fitting this bend)	247726
Wall Liner/Internal Fixing	236441
<b>VERTICAL FLUE KITS</b>	
See the Boiler Installers Guide	
<b>CONTROL ACCESSORIES</b>	
Programmable Room Thermostat (24 hour)	236254
Programmable Room Thermostat (7 day)	238326
Integral Electronic Timer Kit (7 day)	247207
Integral Electro-Mechanical Timer Kit (12 hour am/pm)	247206
<b>FUEL KIT</b>	
LPG Conversion. Propane / Butane	247372

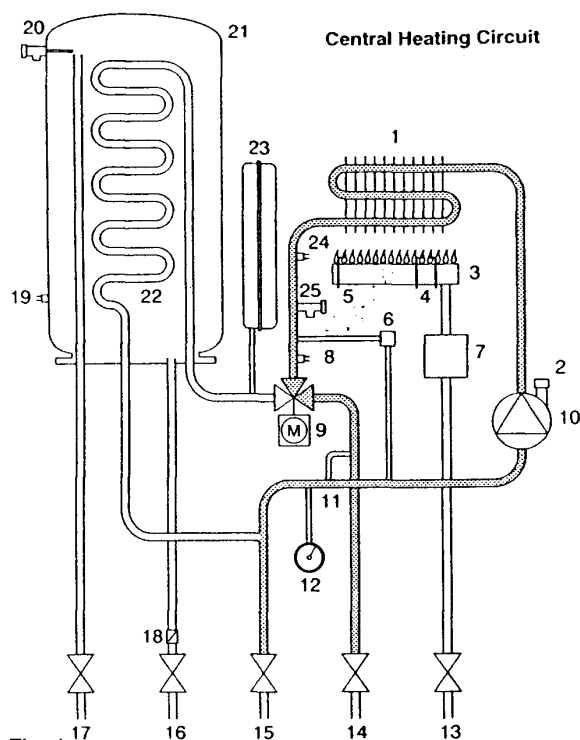

Fig. 4

- |                                 |  |
|---------------------------------|--|
| Main Heat Exchanger             | 14 Heating Flow                          |
| Automatic Air Vent              | 15 Heating Return                        |
| Burner                          | 16 Cold Water Inlet                      |
| Ignition Electrodes             | 17 Domestic Hot Water Outlet             |
| Flame Sensing Electrode         | 18 Flow Restrictor                       |
| Differential Pressure Switch    | 19 Hot Water Storage Temperature Sensor  |
| Gas Valve                       | 20 Temperature/Pressure Relief Valve     |
| Primary Flow Temperature Sensor | 21 Storage Cylinder                      |
| 3-Way Diverter Valve            | 22 Secondary Heat Exchanger              |
| 0 Pump                          | 23 Central Heating Expansion Vessel      |
| 1 By-Pass                       | 24 Safety Unit Thermostat                |
| 2 Pressure Gauge                | 25 Central Heating Pressure Relief Valve |
| 3 Gas Inlet                     |  |

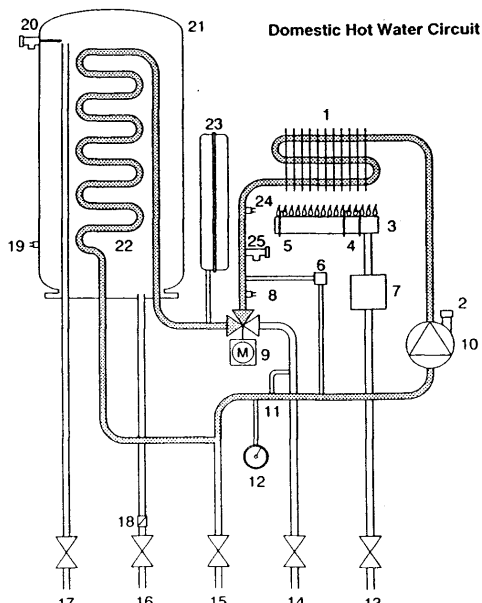

Fig. 5

### 1.3 Boiler Operation

1. The boiler operating mode is controlled by the selector switch on the control panel. When set to it will operate in the Domestic Hot Water and Central Heating modes. For Domestic Hot Water only the selector switch should be set to .
2. Domestic hot water supply always takes priority over central heating. If a demand for hot water is required during a central heating period, the boiler will automatically switch to hot water mode until the demand is satisfied i.e. storage water has reached the set temperature. Interruption to the central heating only occurs when there is a demand for hot water and should not be apparent to the User.

#### 3. Central Heating Mode (Fig. 4)

If there is a call for central heating the diverter valve operates and the pump circulates the primary heating water, operating the differential pressure switch. The fan will run at full speed; once the air pressure switch has been proved the burner will light. The burner output then automatically adjusts to suit the system demand; as the temperature of the heating water in the boiler approaches that set by the adjustable central heating control knob the burner output is reduced. When this set temperature is reached, the burner extinguishes and the fan stops. The pump continues to run for 3 minutes to prevent residual heat build up in the boiler. The burner will not re-light for 3 minutes unless there is a demand for domestic hot water during this period.

#### 4. Domestic Hot Water Mode (Fig. 5)

When there is a demand for hot water (temperature of stored hot water is below that set by the thermostat), the pump will start to circulate the primary heating water, operating the differential pressure switch. The fan will run at full speed; once the air pressure switch has been proved the burner will light. The burner output then automatically adjusts to suit the demand required to raise the temperature of the domestic hot water within the store to the temperature set by the adjustable domestic hot water control knob. When this temperature is reached the burner extinguishes and the fan stops. The pump continues to run for 3 minutes to prevent residual heat build up in the boiler. When the hot water demand has been satisfied, the 3-way diverter valve operates to divert the primary heating water to the central heating, if the selector is set to and there is a C.H. demand.

### 3.2 Frost Protection Mode

1. The frost protection feature will operate when the selector switch is in the central heating and domestic hot water mode. The gas and electrical supplies to the boiler must be on and the system pressure between 0.5 and 2.5 bar.
2. If the system temperature falls below 5° C, then the boiler will fire until the water temperature has been raised.
3. Further frost protection can be incorporated by using a frost thermostat to protect the whole system.

### 3.3 Pump Protection

1. With the selector switch in either operating position the pump will automatically operate for 1 minute in every 24 hours to prevent sticking.

Appliance Type	C <sub>12</sub>	C <sub>32</sub>
Appliance Category	CAT II 2H 3+	
Heat Input (gross)	Max	Min
C/H & DHW kW	34.5	13.2
Btu/h	117,740	45047
Heat Output	Max	Min
kW	28.0	10.4
Btu/h	95,555	35,492
Gas Rate (Natural Gas) (After 10 Mins)	Max	Min
m <sup>3</sup> /h	3.29	1.26
ft <sup>3</sup> /h	116	44
Burner Pressure (Natural Gas) Room sealed panel fitted		
	Max Rate	Min Rate
mbar	10.6 ± 0.5	1.7 ± 0.2
in wg	4.24 ± 0.2	0.68 ± 0.2
Inlet Pressure (Natural Gas)		
mbar	20	
in wg	8	
Burner Injector (Natural Gas) 18 x 1.18mm Diameter		
Nox Class	3	
Electrical Supply	230V~ 50Hz	
Power Consumption	190W	
External Fuse Rating	3A	
Internal Fuse Rating	F2A	
External Controls	230V switching	
Electrical Protection	IP44 (IPx4D)	
(Appliance must be connected to an earthed supply)		
Flue Terminal	Diameter	100mm
Dimensions	Projection	93mm
Connections	copper tails	
Gas Supply	-	22mm
Central Heating Flow	-	22mm
Central Heating Return	-	22mm
Cold Water Mains Inlet	-	15mm
DHW Flow	-	15mm
Pressure Relief Discharge	-	15mm
Outercase Dimensions		
Casing Height	-	950mm
Overall Height Inc Flue	-	1080mm
Casing Width	-	600mm
Casing Depth	-	450mm
Clearances		
LH Side	20mm Min	
RH Side	5mm Min	
Above Casing	200mm Min	
Below Casing	250mm Min	
Front	450mm Min (For Servicing)	
Front	5mm Min (In Operation)	
Weights	kg	
Installation Lift Weight	70	
Total Full Weight	130	

### Central Heating Primary Circuit

**Pressures**

CH Expansion Vessel	bar
Nominal Pre-charge	0.8
Safety Discharge	3
Max Operating	2.5
Min Operating	0.5
Recommend Operating	1-2

Max Capacity of CH System 125 litres

Primary Water Content of Boiler 3.2 litres

---

**Recommended System**

Temperature Drop	11°C	20°F
------------------	------	------

---

**Pump**

Available Head See graph below

---

**Built In Bypass** l/h

Min Circulation Rate (CH Primary Circuit) e.g. TRVs all closed	200
--	-----

---

**Water Temperature**

C.H. Flow Temp (adjustable) 30°C to 82°C max (± 5°C)

### DHW Circuit

Time To Raise Water Storage 50°C 12 minutes

Reheat Time 70% of storage 5 minutes

---

**Pressures** bar

Max Operating	8
Min Operating	0.1

Min Operating Pressure at 12 l/min 1.6

---

**Flow Rates** l/min

DHW Flow Rate @ 30°C Rise	14
DHW Flow Rate @ 35°C Rise	11.5
Min Working DHW Flow Rate	1
Max. Flow Rate	16 l/min.

---

**Unvented DHW Expansion Vessel**  
See Section 6.8 for information

**Water Temperature**

D.H.W. Flow Temp (adjustable) 5°C to 65°C max (± 5°C)

---

**Water Storage Volume** 54 litres

**SEDBUK Declaration For Maxflow Combi WM**

**The seasonal efficiency (SEDBUK) is 78.6 %**

This value is used in the UK Government's Standard Assessment Procedure (SAP) for energy rating of dwellings. The test data from which it has been calculated have been certified by 0051.

**LPG Gases / Propane and Butane**

<b>Burner Injector 18 x 0.69mm diameter</b>		
<b>Burner Pressure</b>	<b>Max Rate</b>	<b>Min Rate</b>
Propane mbar	35.5	7.6
in wg	14.2	3.0
Butane mbar	27.5	4.1
in wg	11.0	1.6
<b>Inlet Pressures</b>	<b>Butane</b>	<b>Propane</b>
mbar	28	37
in wg	11.2	14.8

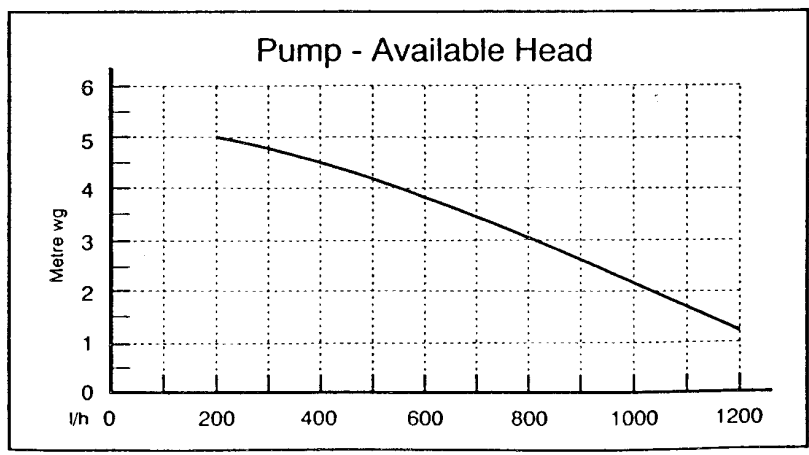

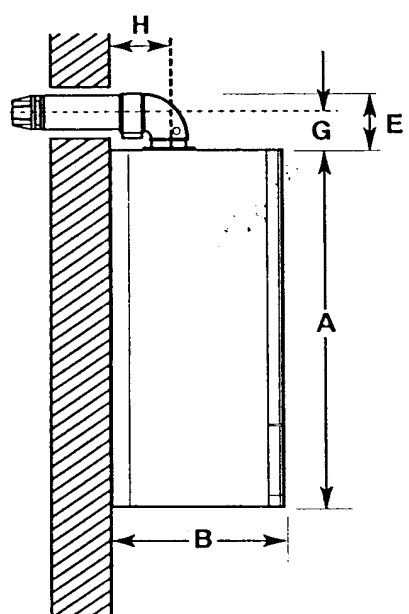

DIMENSIONS	
A	950mm
B	450mm
C	600mm
D	107mm Ø Min.
E	180mm
F	160mm
G	120mm
H	160mm

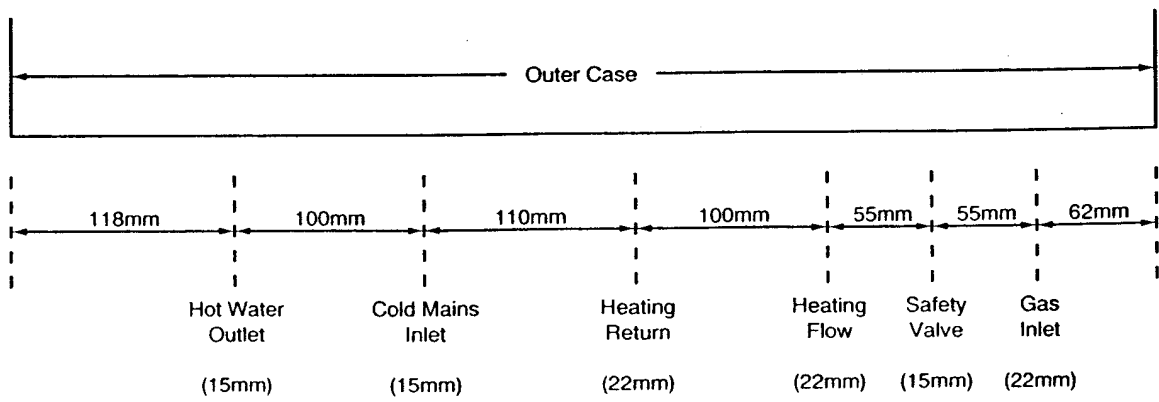
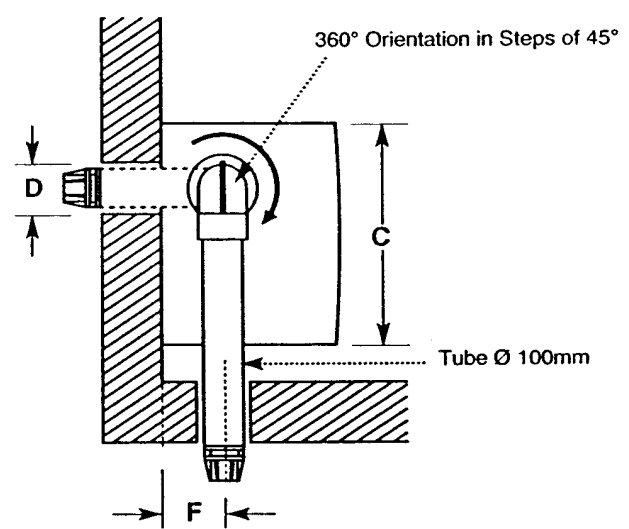

### 6.1 Information

1. The Baxi Maxflow Combi WM Combination Boiler is a 'Water Byelaws Scheme - Approved Product'. To comply with the Water Byelaws your attention is drawn to the following installation requirements and notes (IRN).

- a) IRN 001-- See text of entry for installation requirements and notes.
- b) IRN 116 - Byelaw 90 and 91.
- c) IRN 302 - Byelaw 14.

2. Reference to the WRc publications, 'Water fittings and materials directory' and 'Water supply byelaws guide' give full details of byelaws and the IRNs.

### 6.2 Central Heating Circuit

1. The appliance is suitable for fully pumped SEALED SYSTEMS ONLY.

#### Treatment of Water Circulating Systems

- All recirculatory water systems will be subject to corrosion unless an appropriate water treatment is applied. This means that the efficiency of the system will deteriorate as corrosion sludge accumulates within the system, risking damage to pump and valves, boiler noise and circulation problems.
- For optimum performance after installation this boiler and its associated central heating system must be flushed in accordance with the guidelines given in BS 7593 "Treatment of water in domestic hot water central heating systems".
- This must involve the use of a proprietary cleanser, such as BetzDearborn Sentinel X300 or X400, or Fernox Superfloc. Full instructions are supplied with the products, but for immediate information please contact BetzDearborn (0151 420 9563) or Fernox (01799 550 811) directly.
- For long term protection against corrosion and scale, after flushing it is recommended that an inhibitor such as BetzDearborn Sentinel X100, or Fernox MB-1 or Copal is dosed in accordance with the guidelines given in BS 7593.

#### **Failure to flush and add inhibitor to the system may invalidate the appliance warranty.**

- It is important to check the inhibitor concentration after installation, system modification and at every service in accordance with the manufacturer's instructions. (Test kits are available from inhibitor stockists.)
- For information or advice' regarding any of the above contact the Baxi Helpline.

### **6.3 Bypass**

1. The boiler has an integral bypass and in most cases this should suffice. However in certain circumstances, e.g. on systems where there is a high resistance and TRV's are fitted to all the radiators it may be necessary to fit an external by-pass. For example, a 15mm pipe between the flow and return controlled by a valve, or an uncontrolled radiator.

### **6.4 System Control**

1. The boiler is designed for use in a heating system that incorporates external controls, i.e. a minimum of a timer device.
  2. Suitable timer kits are available as optional extras.
  3. For optimum operating conditions and maximum economy the fitting of a programmable thermostat, such as one of the Baxi Maxflow Combi WM Controllers, is recommended.
-

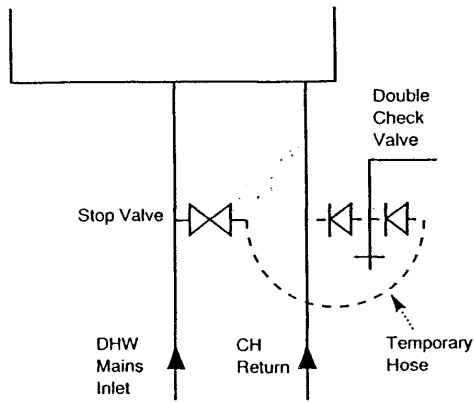

Fig. 6

**6.5 System Filling and Pressurising**

1. A filling point connection on the central heating return pipework must be provided to facilitate initial filling and pressurising and also any subsequent water loss replacement/refilling.
2. The filling method adopted must be in accordance with all relevant water supply bye-laws and use approved equipment.
3. Your attention is drawn to: IRN 302 and Byelaw 14.
4. The sealed primary circuits may be filled or replenished by means of a temporary connection between the circuit and a supply pipe, provided a 'Listed' double check valve or some other no less effective backflow prevention device is permanently connected at the inlet to the circuit and the temporary connection is removed after use (Fig. 6).

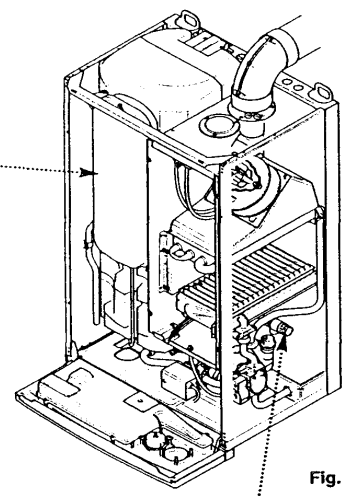

Fig. 7

**6.6 Expansion Vessel (Fig. 7) (Central Heating only)**

1. The appliance expansion vessel is pre-charged to 0.8 bar. Therefore, the cold fill pressure is 0.8 bar. The vessel is suitable for correct operation for system capacities up to 125 litres (27.5gal). For greater system capacities an additional expansion vessel must be fitted - refer to BS 7074 Pt 1.

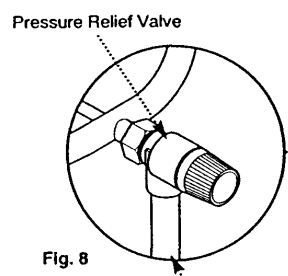

Fig. 8

**6.7 Pressure Relief Valve (Fig. 8)**

1. The pressure relief valve is set at 3 bar, therefore all pipework, fittings, etc. should be suitable for pressures in excess of 3 bar.
2. The pressure relief discharge pipe should be not less than 15mm dia, run continuously downward, and discharge outside the building, preferably over a drain. It should be routed in such a manner that no hazard occurs to occupants or causes damage to wiring or electrical components. The end of the pipe should terminate facing down and towards the wall (Fig. 9).
3. The discharge must not be above a window, entrance or other public access. Consideration must be given to the possibility that boiling water/steam could discharge from the pipe.

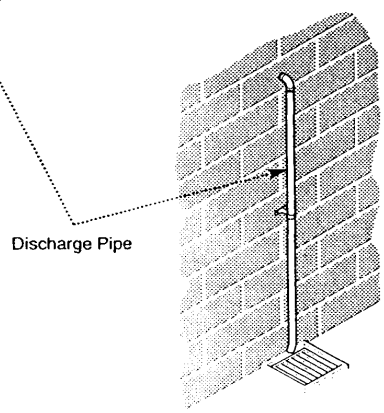

Fig. 9

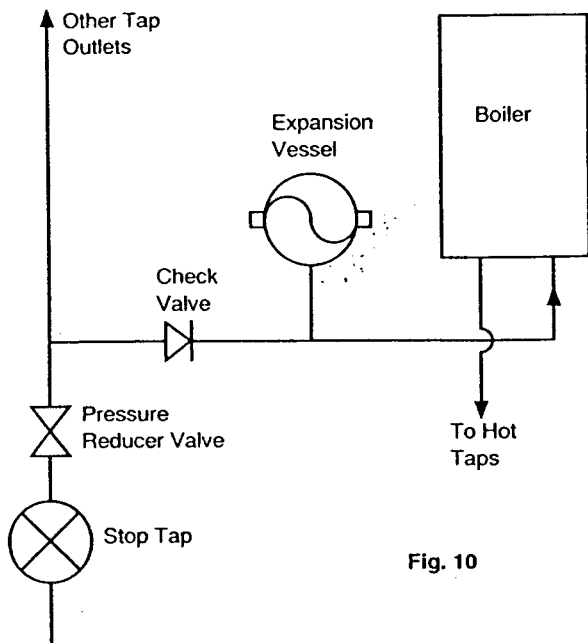

Fig. 10

### 6.8 Domestic Hot Water Circuit

1. All DHW circuits, connections, fittings, etc. should be fully in accordance with relevant standards and water supply bye-laws.
2. Your attention is drawn to: IRN 116 and Byelaw 90 and 91. Sealed primary circuits and/or secondary hot water systems shall incorporate a means for accommodating the thermal expansion of water to prevent any discharge from the circuit and/or system, except in an emergency situation.
3. When the system includes any device which prevents water expanding back towards the supply (check valve, loose jumpered stopcock, water meter, water treatment device), then an expansion vessel must be fitted (e.g. Zilmet 160ml, R ½ 15bar). To comply with Byelaw 91, a check valve must also be fitted on the supply as shown, to ensure efficient operation and also to prevent the reverse flow of hot water into the supply pipe.
4. The boiler's maximum working mains pressure is 8 bar, therefore all pipework, connections, fittings, etc. should be suitable for pressures in excess of 8 bar. The pressure reducing valve supplied in the 'Unvented Kit' must be fitted. The manufacturer of any outlet fittings, such as a shower valve, may require a lower maximum pressure. The pressure reduction must take account of all fittings connected to the DHW system.

### 6.9 Showers

1. If a shower control is supplied from the appliance it should be of the thermostatic or pressure balanced type. Thermostatic type shower valves provide the best comfort and guard against water at too high a temperature. Existing controls may not be suitable - refer to the shower valve manufacturer.

### 6.10 Hard Water Areas

1. If the area of the installation is recognised as a HARD WATER AREA then a suitable device should be fitted to treat the mains water supply to the boiler.

## 7.0 Site Requirements - Page 13

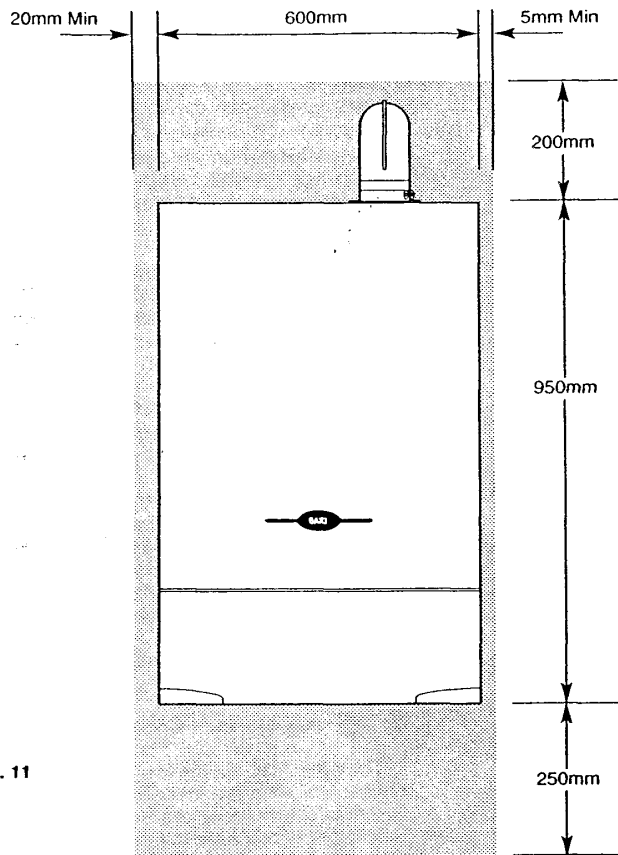

Fig. 11

### 7.1 Information

1. The installation must be carried out by a CORGI Registered Installer or other registered competent person and be in accordance with the relevant requirements of the current Gas Safety (Installation and Use) Regulations, the Building Regulations (Scotland) (Consolidation), the Local Building Regulations, the current I.E.E. Wiring Regulations and the bye laws of the Local Water Undertaking. Where no specific instruction is given reference should be made to the relevant British Standard Codes of Practice. For Ireland install in accordance with IS 814 "Installation of Gas Appliances".

STANDARD	SCOPE
B S 6891	Gas Installation
B S. 5440: Pt 1	Flues
B S. 5440: Pt 2	Air Supply.
B S. 5546	Installation of hot water supplies for domestic purposes.
B S. 7074	Expansion vessels and ancillary equipment for sealed water systems.
B S. 5449: Pt 1	Forced circulation hot water systems.
B S. 6798	Installation of gas fired hot water boilers.

**WARNING -** The addition of anything that may interfere with the normal operation of the appliance without the express written permission of Baxi UK Limited could invalidate the appliance warranty and infringe the Gas Safety (Installation and Use) Regulations.

### 7.3 Clearances (Fig. 11 & 12)

1. A flat vertical area is required for the installation of the boiler.
2. The clearances around the outer case are for the flue elbow, pipework etc. The clearance in front of the appliance is for servicing purposes when installed in a cupboard or compartment.
3. Additional clearances at the side must be left to accommodate any rising pipework. It is not possible to route any pipework within the outercase.

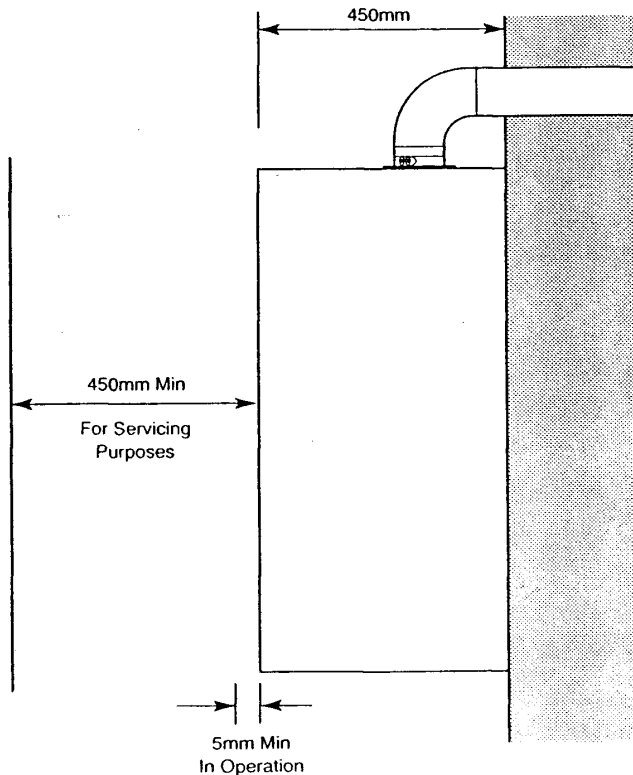

Fig. 12

### 7.4 Location

1. The boiler may be fitted to any suitable wall with the flue passing through an outside wall or roof and discharging to atmosphere in a position permitting satisfactory removal of combustion products and providing an adequate air supply. The wall must be capable of supporting the weight of the appliance.
2. The boiler should be fitted within the building unless otherwise protected by a suitable enclosure i.e. garage or outhouse. (The boiler may be fitted inside a cupboard - see Section 7.5).
3. If the boiler is sited in an unheated enclosure then it is recommended to leave the ON/OFF Selector Switch in the domestic hot water and central heating position to give frost protection.
4. If the boiler is fitted in a room containing a bath or shower reference must be made to the current I.E.E. Wiring Regulations and Building Regulations. If the boiler is to be fitted into a building of timber frame construction then reference must be made to the current edition of Institute of Gas Engineers Publication IGE/UP/7 (Gas Installations in Timber Framed Housing).

### 7.5 Ventilation of Compartment

1. The boiler does not require any air vents in the room in which it is installed. If it is installed in a cupboard or compartment permanent air vents are required at high and low levels (see Table 1). The vents must communicate with the same room or be direct to outside on the same wall.
2. When installed in a cupboard or compartment a 75mm clearance for air movement must be left in front of the boiler when any door or panel is closed

### 7.6 Gas Supply

1. The gas installation should be in accordance with BS6891.
2. The connection to the appliance is a 22mm copper tail. This is connected to the gas service cock (Fig. 14).
3. Ensure that the pipework from the meter to the appliance is of adequate size. Do not use pipes of a smaller diameter than the boiler gas connection (22mm).

### 7.7 Electrical Supply

1. External wiring must be correctly earthed, polarised and in accordance with current I.E.E. Wiring Regulations.
2. The mains supply is 230V ~ 50Hz fused at 3A.

**NOTE: The method of connection to the electricity supply must facilitate complete electrical isolation of the appliance. Connection may be via a fused double-pole isolator with a contact separation of at least 3mm in all poles and servicing site boiler and system controls only.**

Free area of air vent (cm <sup>2</sup> )		
Position of vent	Air from room	Air from outside
High Level	310.5	155.25
Low Level	310.5	155.25

Table 1

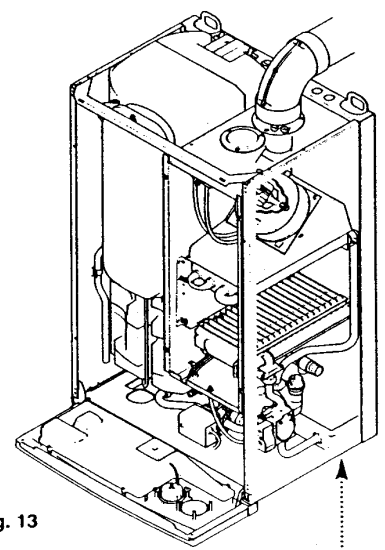

Fig. 13

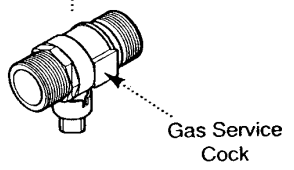

Fig. 14

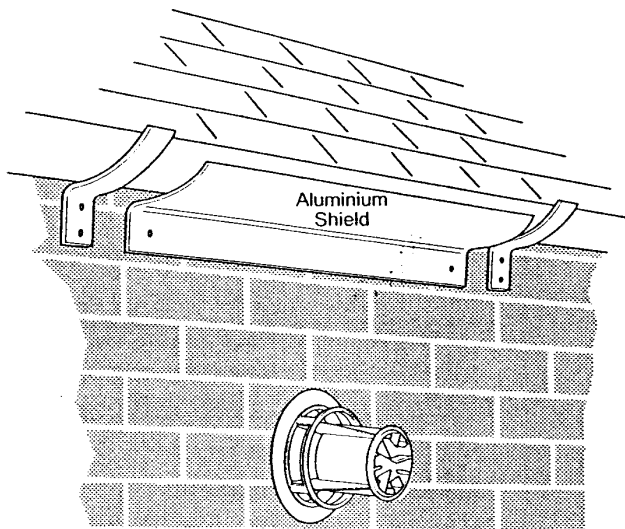

Fig. 15

7.8 Flue

1. An internal fitting kit is available for installations where the flue terminal is inaccessible from the outside. This is available direct from Baxi UK Limited. Quote Part N° 236441 when ordering.

2. The following guidelines indicate the general requirements for siting balanced flue terminals. Recommendations for flues are given in BS 5440 Pt.1.

3. If the terminal is fitted within 850mm of a plastic gutter, within 450mm of a painted eave or a painted gutter, an aluminium shield of at least 1 metre long should be fitted to the underside of the gutter or painted surface. An air space of 5mm should be left between shield and gutter (Fig. 15).

4. If the terminal discharges onto a pathway or passageway, check that combustion products will not cause a nuisance and that the terminal will not obstruct the passageway.

5. If a terminal is less than 2 metres above a balcony, above ground or above a flat roof to which people have access, then a suitable terminal guard must be provided.

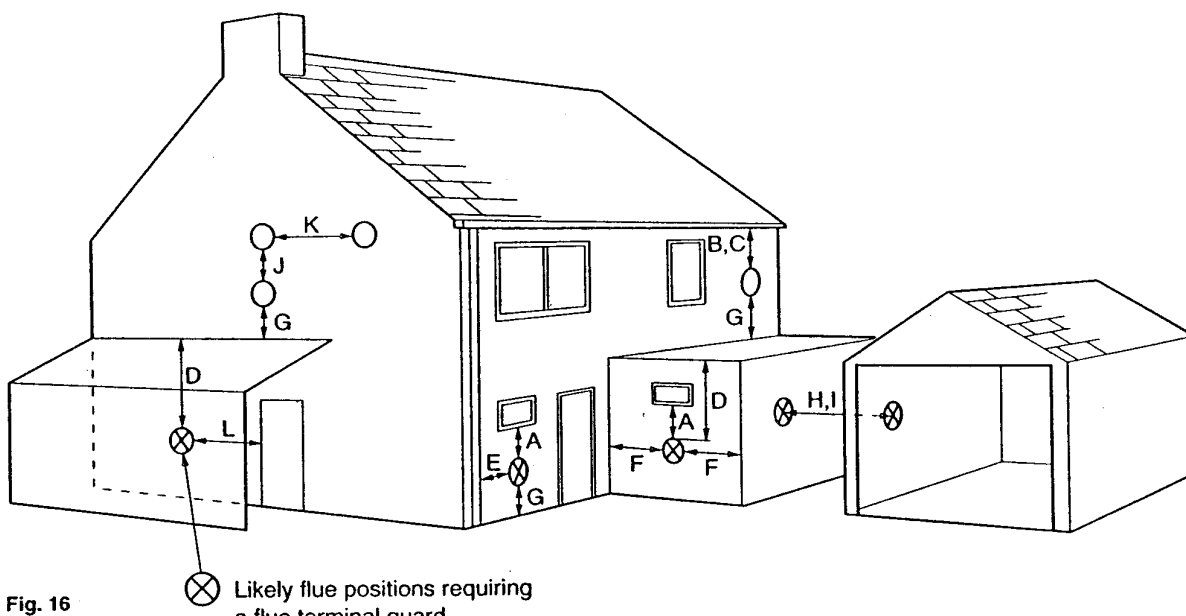

Fig. 16

Likely flue positions requiring a flue terminal guard

Terminal Position with Minimum Distance (Fig. 10)	mm
A Directly below an openable window or Other opening. e.g. an air brick.	300
B Below eaves.	25
C Below gutters, soil pipes or drain pipes.	75
D Below balconies or car port roof.	25
E From vertical drain pipes and soil pipes.	25
F From internal or external corners.	25
G Above ground. roof or balcony level.	300
H From a surface facing a terminal.	600
I From a terminal facing a terminal.	1200
J Vertically from a terminal on the same wall.	1500
K Horizontally from a terminal on the same wall.	300
L For an opening in a car port (e.g. door, window) into a dwelling.	1200

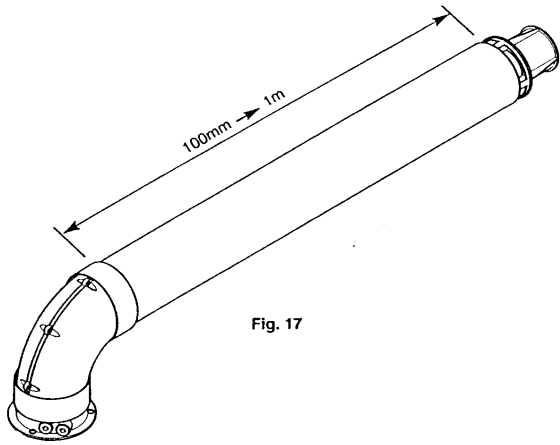

Fig. 17

### 7.9 Flue Dimensions

The standard horizontal flue kit allows for flue lengths between 100mm and 1m from elbow to terminal (Fig. 17).

**The maximum permissible equivalent flue length is: 4 metres.**

**NOTE: Each additional 45° of flue bend will account for an equivalent flue length of 0.5m. eg. 45° = 0.5m, 90° = 2 x 45° = 1m etc.**

### 7.10 Flue Terminal Trim

1. Once the flue is secure the trim can be fitted if required.
2. Remove the protective backing from the adhesive seal. Apply the seal to the rear of the trim flange (Fig. 18).
3. Locate the trim over the flue terminal and push it back to the wall to compress the seal (Fig. 19).

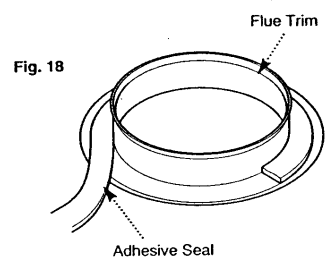

Fig. 18

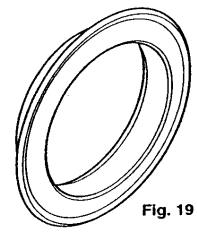

Fig. 19

### 7.11 Terminal Guard (Fig. 20)

1. When codes of practice dictate the use of terminal guards, they can be obtained from most Plumbers' and Builders' Merchants.
2. When ordering a terminal guard, quote the appliance model number.
3. The guard manufacturers listed below can be contacted for terminal sizes and guard model numbers.

Tower Flue Components Ltd.,  
 Tower House,  
 Vale Rise,  
 Tonbridge,  
 Kent.  
 Tel: 01732 351555.

Quinnell, Barrett & Quinnell,  
 884 Old Kent Road,  
 London,  
 SE15 1NL.  
 Tel: 0171 639 1357.

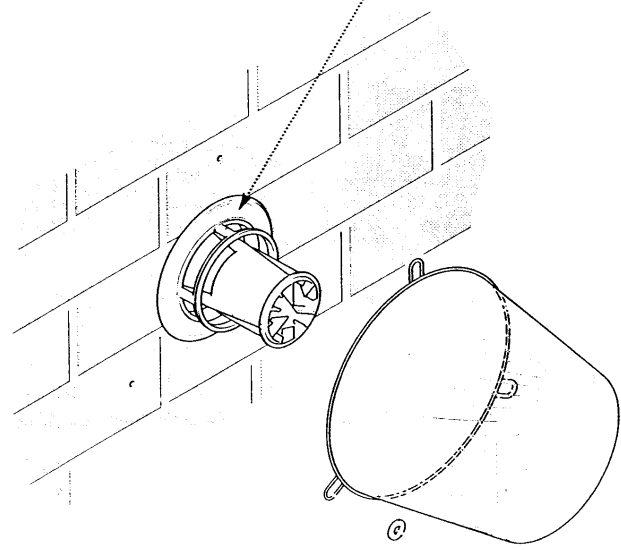

Fig. 20

4. The flue terminal guard should be positioned centrally over the terminal and fixed as illustrated.

### 7.12 Flue Options

1. The Baxi Maxflow Combi WM can be fitted with flue systems as illustrated.
2. The standard flue is suitable only for horizontal applications.
3. Maximum permissible equivalent flue lengths are:

Horizontal	4.0 metres
Vertical	4.0 metres
Vertical (Twin Pipe)	15.0 metres

4. Any additional "in line" bends in the flue system must be taken into consideration.

Their equivalent lengths are:-

Concentric Pipes:	
45° bend	0.5 metres
90° bend	1.0 metres
Twin Flue Pipe	
45° bend	0.25 metres
90° bend	0.50 metres

The elbow supplied with the standard horizontal flue is not included in any equivalent length calculations. This elbow is of the same type as the optional concentric 90° bend.

Bends can be used to route the flue pipe around obstacles within the dwelling and to enable the flue terminal to be positioned according to requirements.

By combining two 45° bends and a straight piece, a wide 90° bend can be achieved. As it is possible to rotate the bends through 360°, various "S" bends can be produced.

5. The illustrations opposite show examples of maximum equivalent lengths.
6. Full details of part numbers and descriptions of all optional flue components and kits can be found in the Baxi Gas Central Heating Boilers Installers' Guide.
7. Instructions for guidance and fitting are included in each kit.

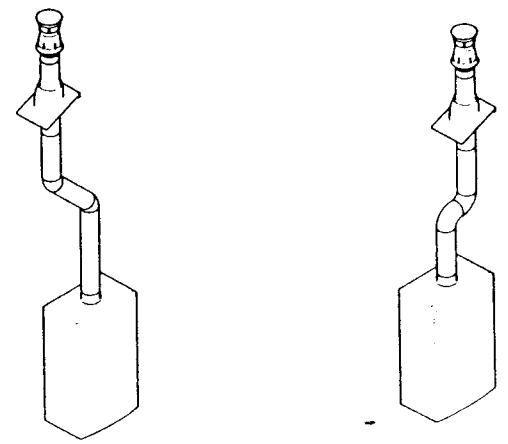
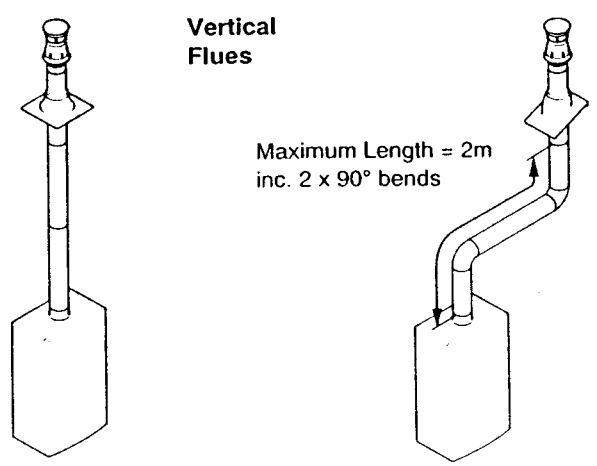
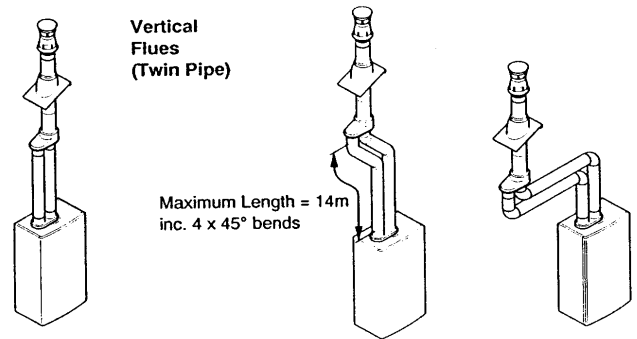
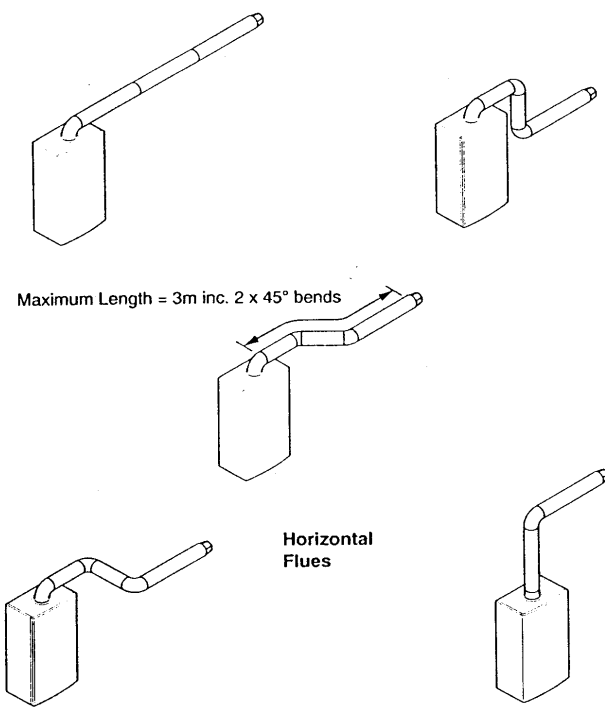

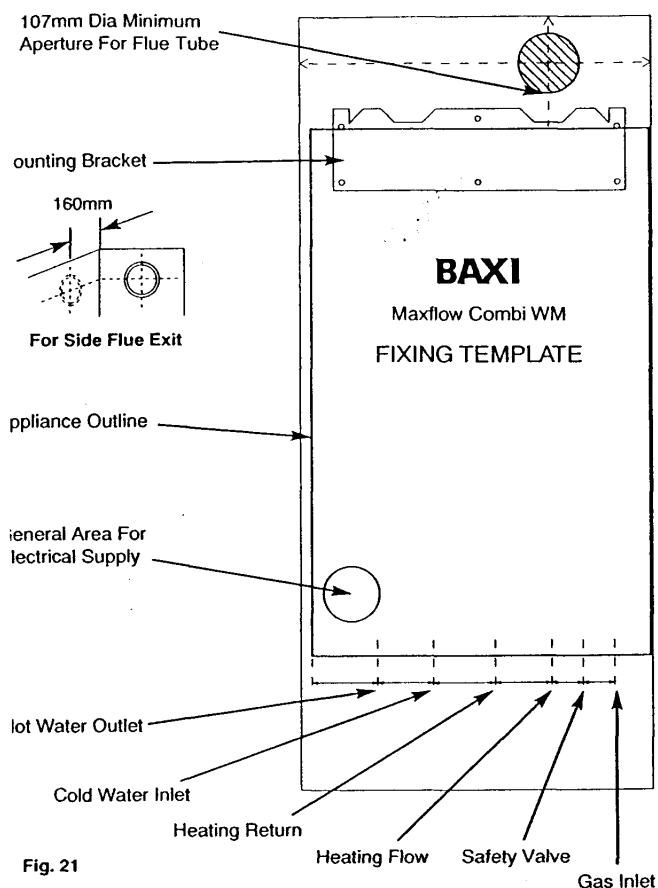

Fig. 21

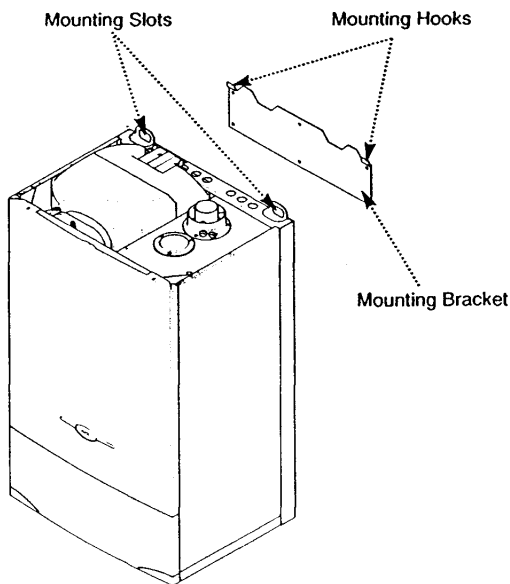

Fig. 22

### 8.1 Initial Preparation & Fitting the Boiler

**The gas supply, gas type and pressure must be checked for suitability before connection (see Section 7.6).**

1. Locate the wall template (Fig. 21) in the appliance packaging.
2. After considering the site requirements (see Section 7.0) position the template on the wall ensuring it is level both horizontally and vertically.
3. Select the six most suitable fixing holes and mark their position.
4. Mark the centre of the flue hole (rear exit). For side exit, mark as shown. If required, mark the position of the gas and water pipes. Remove the template.
5. Cut the hole for the flue (minimum diameter 107mm).
6. Drill and plug the mounting bracket fixing holes.
7. Using the screws and washers provided, secure the mounting bracket to the wall.
8. Lift the boiler and locate the slots in the upper chassis over the hooks on the mounting bracket (Fig. 22).

**THIS OPERATION WILL REQUIRE ASSISTANCE!**

9. Remove the sealing plugs from the gas and water connections.
10. Connect the gas and water valves together with the appropriate copper tail ensuring that the sealing washers are correctly fitted.

**NOTE: The rubber gas sealing washers are an integral part of the gas valve.**

### 8.2 Flushing

1. Thoroughly flush the system - see Section 6.2.

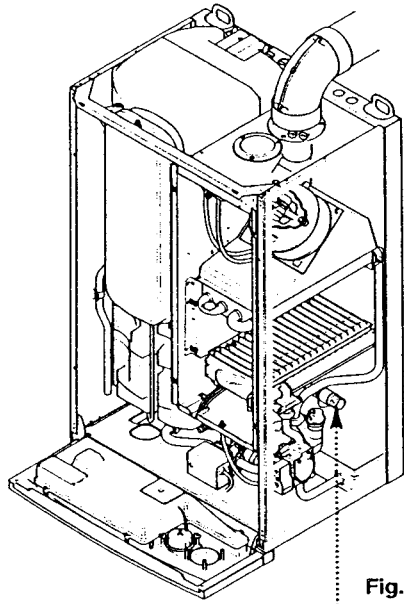

Fig. 23

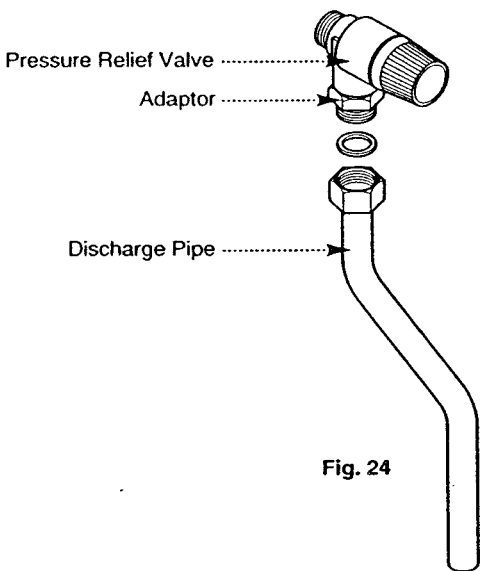

Fig. 24

### 8.3 Fitting the Pressure Relief Discharge Pipe (Fig. 24)

1. Remove the discharge pipe from the kit.
2. Determine the routing of the discharge pipe in the vicinity of the boiler. Make up as much of the pipework as is practical, including the discharge pipe supplied.
3. The pipework must be at least 15mm diameter and run continuously downwards to a discharge point outside the building. See section 6.7 for further details.
4. Utilising one of the sealing washers, connect the discharge pipe to the adaptor and tighten the nut.
5. Complete the discharge pipework and route it to the outside discharge point.

### 8.4 Unvented Hot Water Storage

**NOTE: The installation is subject to Building Regulations approval and the Local Authority must be informed of the intent to install. Consideration must be given to Building Regulations document G3.**

1. The components supplied in the box marked 'Unvented Kit' **MUST** be fitted to the mains water supply.
2. No isolating valves must be fitted between these components and the boiler.
3. The combined filter and pressure reducing valve must ideally be fitted before the mains water supply divides to feed the boiler and the rest of the dwelling.
4. The discharge pipes from the expansion relief valve supplied in the kit and the temperature/pressure relief valve on the boiler storage cylinder must be routed to the tundish supplied.
5. These discharge pipes must be 15mm, and the pipe downstream of the tundish at least 22mm.
6. See the instructions supplied in the unvented kit for full details.

### 8.5 Fitting The Flue

#### HORIZONTAL FLUE

1. The standard flue is suitable for lengths 100mm minimum to 1m maximum (measured from the edge of the flue elbow outlet).

- Rear Flue:** maximum wall thickness - 900mm
- Right Side Flue:** maximum wall thickness - 875mm
- Left Side Flue:** maximum wall thickness - 615mm

2. If using the optional internal fitting kit, flue extension kit or elbows, refer to the instructions provided with the kits.

3. Locate the flue elbow on the adaptor at the top of the boiler. Set the elbow to the required orientation (rear, right or left).

4. Measure the distance from the outside wall face to the elbow (Figs. 25 & 26). This dimension will be known as 'X'.

5. Taking the air duct, mark dimension 'X' as shown (Fig. 27). Measure the length of waste material, and transfer the dimension to the flue duct (Fig. 27).

6. Remove the waste from both ducts. Ensure that the cut ends are square and free from burrs.

7. Remove the flue elbow from the adaptor.

**IMPORTANT: Check all measurements before cutting**

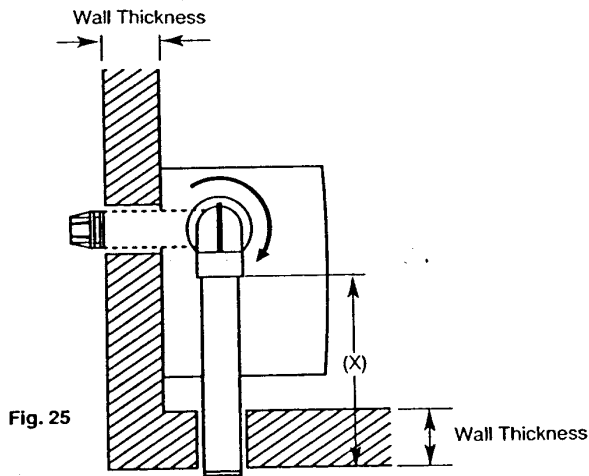

Fig. 25

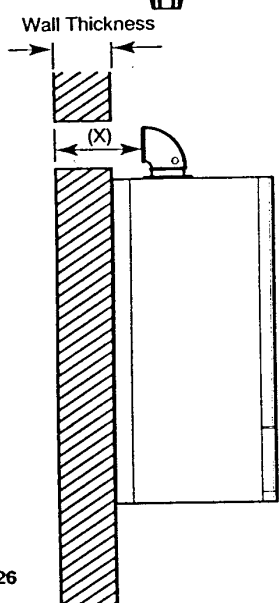
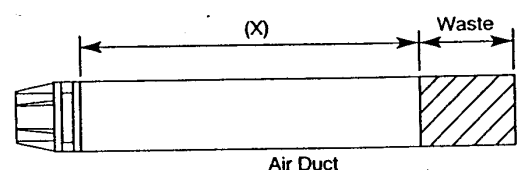
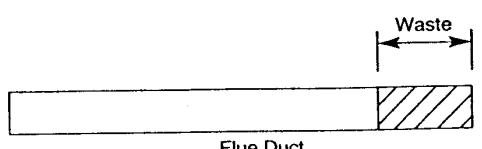

Fig. 26



Air Duct



Flue Duct

Fig. 27

### 8.5 Fitting the Flue (Cont)

12. Insert the flue duct into the air duct and pass them through the hole in the wall.

13. Take one of the rubber seals and position it on the boiler flue adaptor. Engage the flue elbow on the adaptor and pull the sleeve up so that it equally covers the joint (Fig. 28).

14. Remove the screws from one of the clips provided. Prise the clip apart and fit it over the seal. Set the elbow to the required angle (Fig. 29).

15. Refit the screws to the clip and tighten them to secure the elbow. Take the second rubber seal and position it on the flue elbow.

16. Locate the flue duct clamp on the flue outlet elbow. Draw the flue duct out of the air duct, engage it in the clamp and tighten the screws (Fig. 30).

17. Draw the air duct out of the wall and align it with the elbow. Position the seal so that it equally covers the joint (Fig. 31).

18. Remove the screws from the second clip provided. Prise the clip apart and fit it over the seal. Refit the screws to the clip and tighten them (Fig. 31).

19. Where possible position the clips so that the screws are not visible.

20. Make good between the wall and air duct outside the building.

21. Fit the circular flue trim outside if required, and if necessary fit a terminal guard (see Section 7.10 & 7.11).

#### VERTICAL FLUE

1. Only a flue approved with the Baxi Maxflow Combi WM can be used.

2. For information on vertical flues consult the Baxi Maxflow Combi WM Installer Guide or Notes for Guidance supplied with the vertical flue pack.

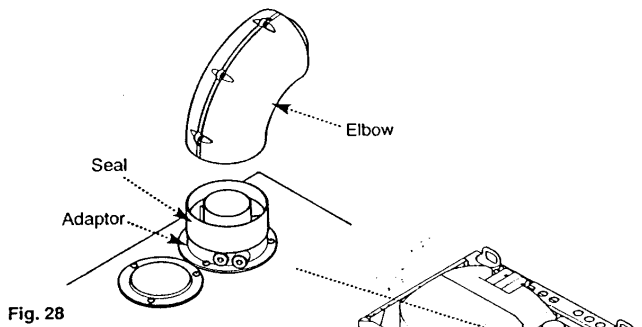

Fig. 28

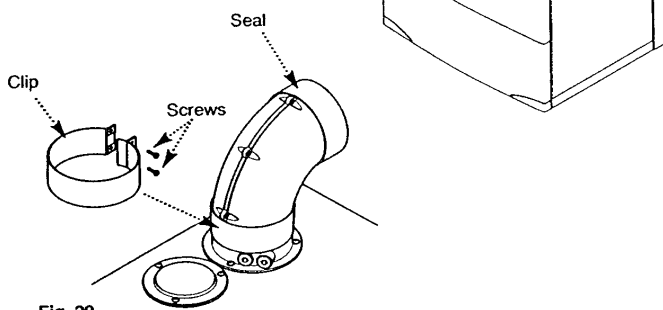

Fig. 29

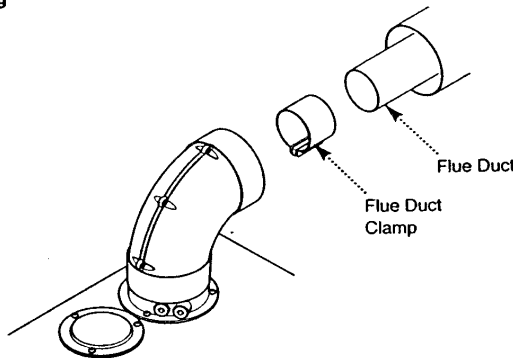

Fig. 30

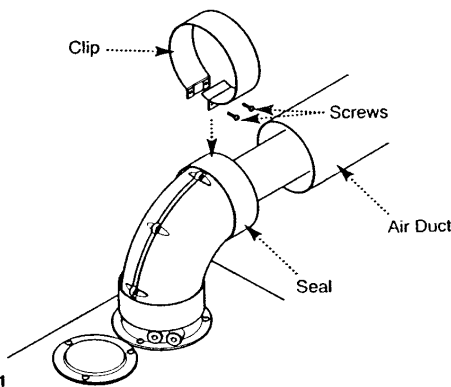
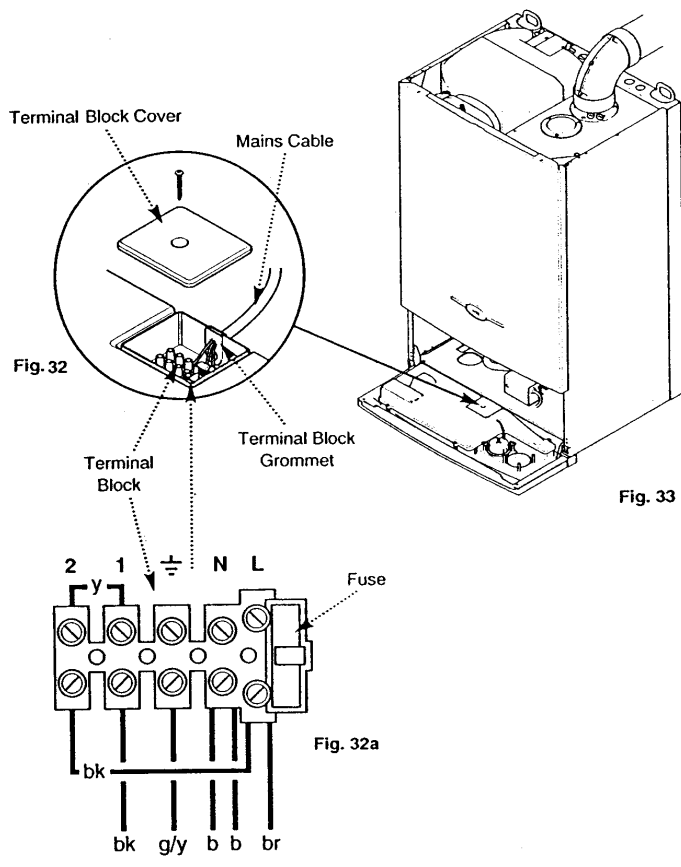

Fig. 31

### 8.6 Making The Electrical Connections

To connect the mains input cable proceed as follows:-

1. Hinge the facia panel downwards and undo the two screws retaining the control box to the boiler chassis. Allow the control box to hinge down (Fig. 33).
2. Slacken the cable clamp on the LH side of the boiler chassis. Insert the cable through the clamp and route it to the terminal block.
3. Undo the screw retaining the terminal block cover and remove the cover. Remove the terminal block grommet and cut to accept the cable. Pass the cable through the grommet (Fig. 32).
4. Slacken the screws in the terminal block, connect the input cable, and tighten the screws. Replace the grommet in the control box slot (Fig. 32).
5. If an external control is to be connected it can be done at this point. Run the input cable from the external control through the second cable clamp on the boiler chassis. Refer to the instructions supplied with the control.
6. Pass the cable through the terminal block grommet, cutting the grommet to accept the cable.
7. Remove the link between terminal 1 and 2 (Fig. 32a) and connect the cables from the external control.



**IMPORTANT: The external control MUST be suitable for 230V switching.**

8. Ensure that both mains input and, where fitted, external control input cables have sufficient slack to allow the control box to drop down. Tighten the cable clamp(s) on the boiler chassis.
9. If the optional integral timer is to be used it should be fitted at this point. Refer to the instructions supplied with the timer.

### 8.7 Preliminary Electrical Checks

1. Prior to commissioning the boiler preliminary electrical system checks should be carried out.
2. These should be performed using a suitable meter, and include checks for Ground Continuity, Resistance to Ground, Short Circuit and Polarity.

Functional Flow Diagram

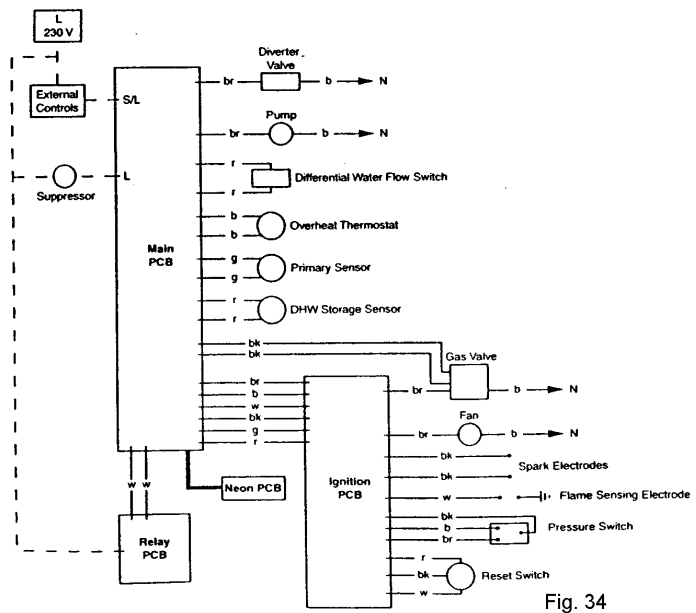

Fig. 34

### 9.1 Commissioning the Boiler

1. Reference should be made to BS 5449 Section 5 when commissioning the boiler.
2. Open the mains water supply to the boiler.
3. Open all hot water taps to purge the DHW system.
4. Ensure that the filling loop is connected and open, then open the heating flow and return valves on the boiler.
5. Open the automatic air vent (Fig. 37).
6. The system must be flushed in accordance with BS 7593 (see Section 6.2) and the flushing agent manufacturers instructions.
7. Pressurise the system to 1.0 bar then close and disconnect the filling loop.
8. Turn the gas supply on and purge the system according to BS 6891.
9. Test for gas soundness.
10. If at any time during commissioning it is required to terminate a particular cycle, e.g. the pump overrun period, turn the selector to the OFF position and then back to either (OFF) or (OFF).

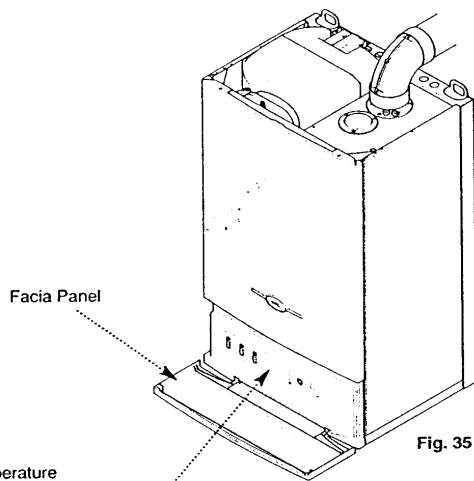

Fig. 35

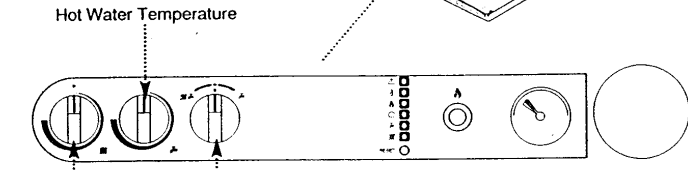

Fig. 36

Hot Water Temperature  
Central Heating Temperature  
Selector Switch

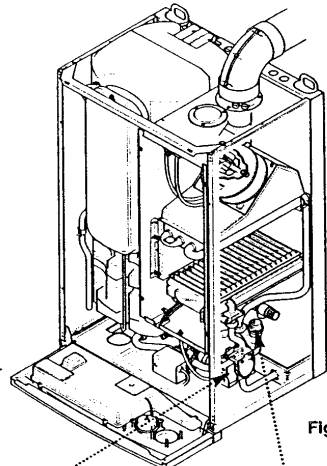

Fig. 37

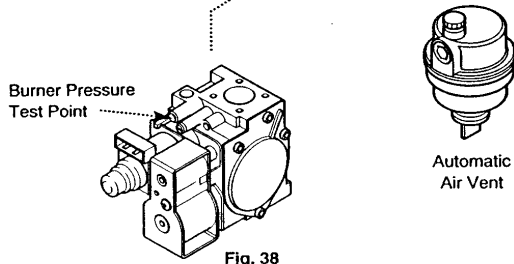

Fig. 38

Burner Pressure Test Point

Automatic Air Vent

### 9.2 Checking the Burner Pressures

1. Turn on the gas and electrical supplies to the boiler and ensure that all external controls are calling for heat.
2. Set the hot water and central heating temperature controls to maximum and the selector switch to the OFF position (Fig. 36).
3. Remove the pressure test point sealing screw from the gas valve and connect a pressure gauge (Fig. 38).

#### Hot Water Mode

4. Turn the selector switch to the Domestic Hot Water position (OFF). The electrical supply ON light (ON) will illuminate (Fig. 36).
5. The burner will light and the pressure should increase to the maximum. This will be maintained for approximately 3 minutes and then decrease gradually to the minimum until the hot water store has reached 65°C.
7. Check the pressures and ensure that the burner extinguishes when the store temperature is reached. The burner pressures are factory set and do not need adjustment.

#### Central Heating Mode

8. Turn the selector switch to the Central Heating and Domestic Hot Water position (OFF)(Fig. 36).

**9.2 Checking the Burner Pressures (continued)**

9. The burner will light and the pressure should increase to the maximum.

Burner Pressures (mbar)	Max.	Min.
	10.8	1.9

10. If the pressures are not as those shown in the table check that the inlet pressure is 20 mbar. To achieve 20 mbar the gas supply pipe must be sized correctly and the supply to the dwelling must be sufficient.

11. It is possible to alter the heat output for central heating if required. The output for both central heating and hot water is factory set at 28.0 kW.

12. To change the central heating output proceed as follows:-

- Set the selector switch to the central heating and domestic hot water position (Fig. 40).
- Turn the central heating temperature control to maximum and the domestic hot water one to minimum (Fig. 40).
- Prise the removable panel off the electrical box cover (Fig. 42).
- Identify the central heating adjustment potentiometer P4 (Fig. 41).
- Using a suitable screwdriver alter the potentiometer to achieve the pressure shown in the table to give the required heat output.
- Replace the removable panel.
- The output to domestic hot water will remain at 28.0 kW.

13. Turn the selector to the OFF position, disconnect the pressure gauge and replace the sealing screw.

14. The system should then be flushed again and treated in accordance with BS 7593 and the flushing agent/inhibitor manufactures instructions.

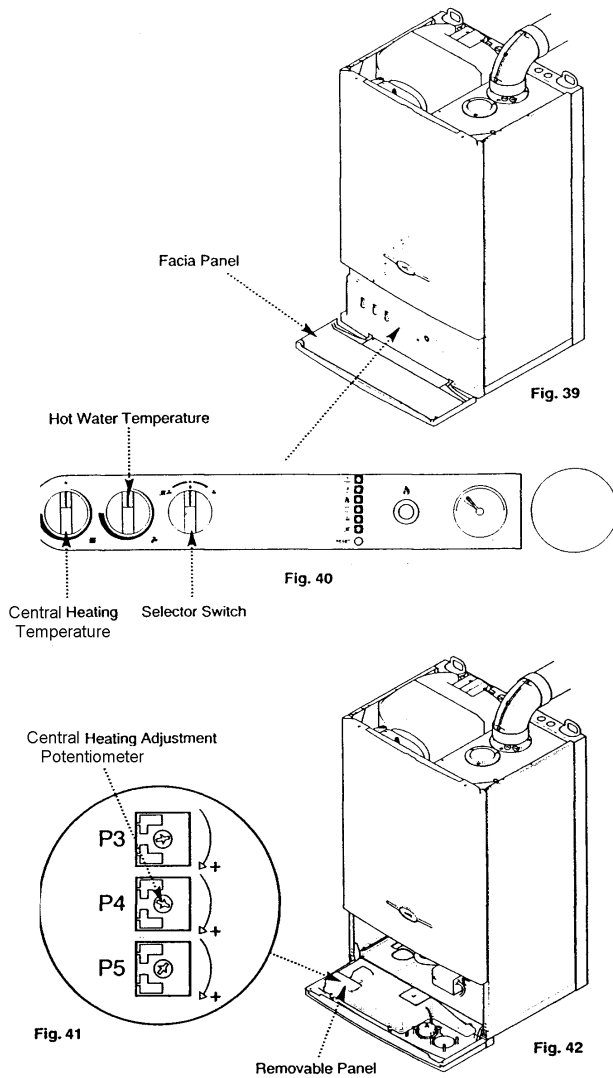

**9.3 Completion**

- Carefully read and complete all sections of the "Benchmark" Installation, Commissioning and Service Record Log Book that are relevant to the appliance and installation. The details of the Log Book will be required in the event of any warranty work. The Log Book must be handed to the user for safe keeping and each subsequent regular service visit recorded.
- Instruct the user in the operation of the boiler controls. Hand over the User's Operating, Installation and Servicing Instructions and the Log Book, giving advice on the necessity of regular servicing.
- Show the user the position of the tundish and discharge pipe.
- Remove the plastic coating from the appliance outercase panels.
- Hinge the facia panel upwards to close it.

mbar <u>Natural Gas</u>	mbar <u>Butane</u>	mbar <u>Propane</u>	<u>kW</u>
<b>1.7</b>	<b>4.1</b>	<b>7.6</b>	<b>10.4</b>
2.1	4.7	8.2	11.6
2.5	5.7	8.9	12.8
2.8	6.8	9.7	14.0
3.1	7.9	10.8	15.1
3.6	9.2	12.0	16.3
4.1	10.5	13.8	17.4
4.7	12.0	15.6	18.6
5.3	13.5	17.7	19.8
6.0	15.2	19.8	20.9
6.6	16.9	22.1	22.1
7.4	18.8	24.4	23.3
8.1	20.7	27.0	24.4
8.9	22.7	29.6	25.6
9.7	24.8	32.3	26.7
<b>10.6</b>	<b>27.5</b>	<b>35.5</b>	<b>28.0</b>

**10.1 Annual Servicing**

1 For reasons of safety and economy, it is recommended that the boiler is serviced annually. Servicing must be performed by a competent person.

2. After servicing, complete the relevant section of the "Benchmark" Installation, Commissioning and Service Record Log Book. This should be in the possession of the user.

3. Whilst the boiler is running measure the CO and CO<sub>2</sub> content of the flue products by removing the LH sample screw on the flue elbow and insert a suitable sampling probe (Fig. 44). If the CO/CO<sub>2</sub> ratio is greater than 0.035 then further servicing and investigation is required.

4. Ensure that the boiler is cool.

**5. Ensure that both the gas and electrical supplies to the boiler are isolated.**

6. Undo the two screws on the top edge of the outcase front panel. Lift the panel slightly and remove it (Fig. 43). Undo the screws securing the combustion box front panel. Remove the panel, being careful not to damage the seal (Fig. 45).

7. Undo the screws securing the combustion box inner panel. Remove the panel and examine the insulation piece (Fig. 45).

8. Hinge the facia panel down and remove the screws securing the control panel. Lower the control panel (Fig. 45).

9. Disconnect the gas supply from the burner inlet manifold and remove the two electrode leads from the burner (Fig. 46).

10. Draw the burner forwards out of the combustion box and disconnect the flame sensing lead. Take care not to damage or lose the sealing washer on the gas inlet flange (Fig. 46).

11. Note the positions of the two sensing tubes and three wires on the pressure switch and remove them.

12. Undo the screws securing the pressure switch to the combustion box bracket and remove the switch.

13. Remove the screws from the flue adaptor clamp. Prise the clamp apart and disengage it from the fan outlet adaptor and boiler flue adaptor. Remove the clamp.

14. Note the positions of the three wires on the fan motor and remove them. Remove the two screws securing the flue hood forward edge.

15. Draw the fan and hood assembly forwards out of the combustion box.

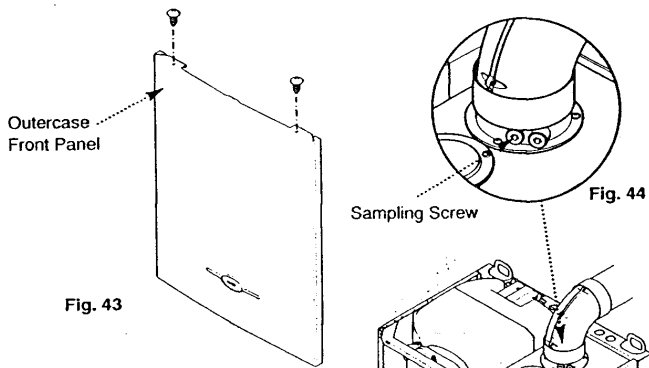

Fig. 43

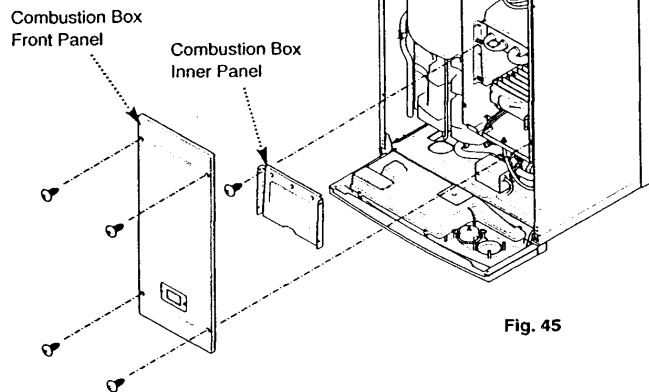

Fig. 45

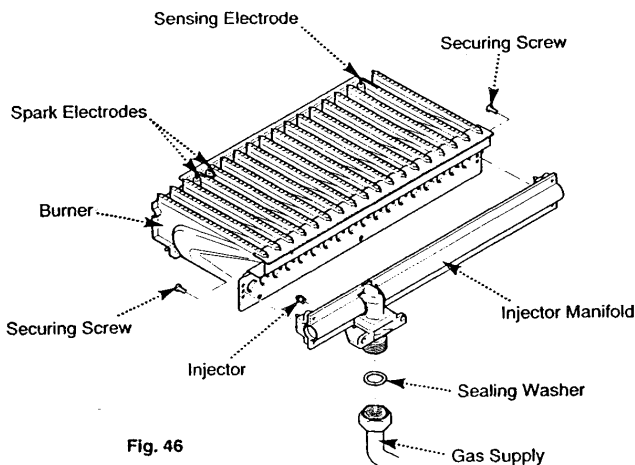

Fig. 46

### 10.1 Annual Servicing (Continued)

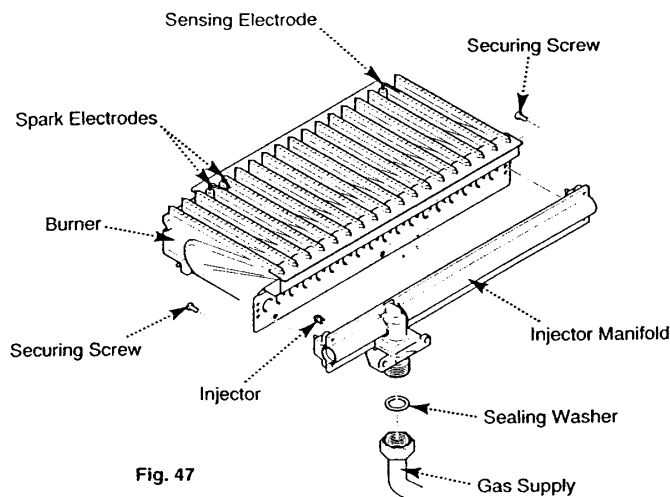

Fig. 47

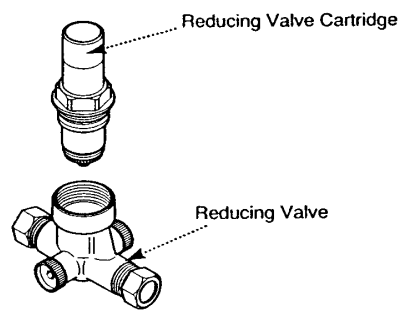

Fig. 48

16. Gently clean the heat exchanger with a soft brush, taking care not to damage any of the fins.

17. Inspect the side insulation pieces and replace if they are damaged or deteriorated in any way and brush out any debris or deposits from the combustion box. Do not allow any foreign matter to enter the gas valve pressure sensor on the combustion box base.

18. Undo the screws securing the injector manifold to the burner assembly and remove the manifold. Examine the injectors for blockage, cleaning as necessary. Do not use hard tools, such as pins or wire (Fig. 47).

19. Clean the burner with a soft brush taking care not to damage the electrodes. Check the condition, positions and gaps of the electrodes.

20. The pressure reducing valve should not require any maintenance on an annual basis, but if problems are experienced with pressure the cartridge should be cleaned.

#### Cleaning The Cartridge

21. Turn off the mains water supply. Fit a suitable hose pipe to the D.H.W. storage drain spigot, and open the valve on the spigot. Hot water must also be run from the highest draw off point in the dwelling to ensure complete draining of the domestic hot water. Unscrew the cartridge from the valve body and rinse thoroughly in clean water (Fig. 48).

22. Reassemble in reverse order of dismantling and re-commission. Check the pressure vessel charge and system pressure.

23. Check the CO/CO<sub>2</sub> ratio is now less than 0.035.

24. Complete the relevant section of the "Benchmark" Installation, Commissioning and Service Record Log Book and hand it back to the user.

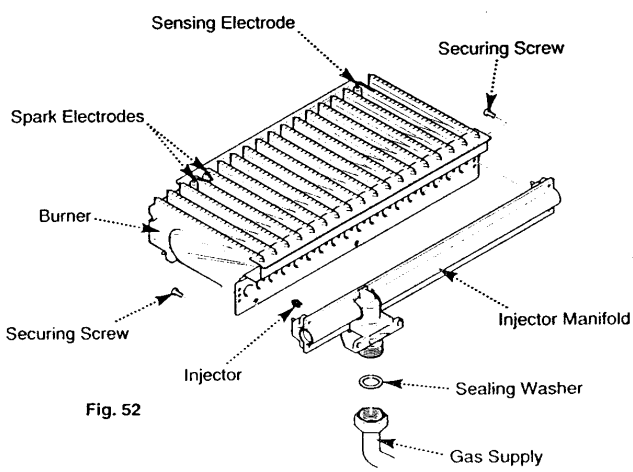
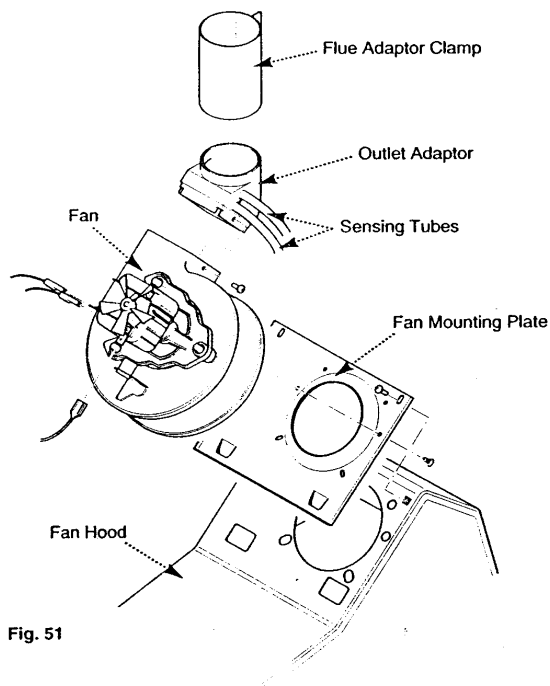
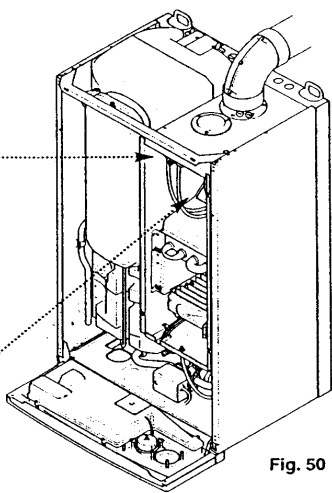
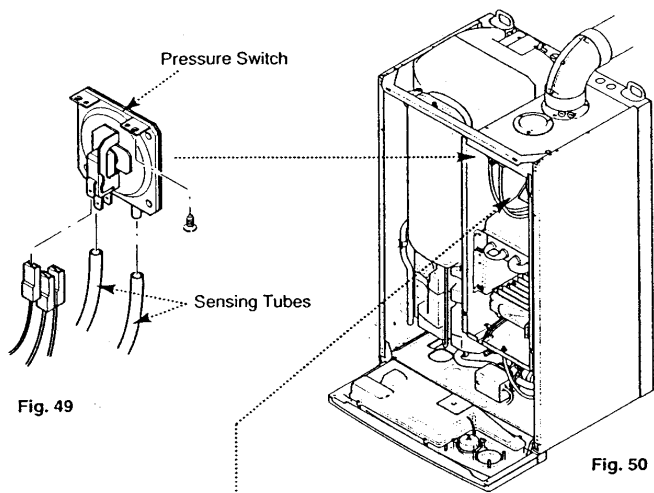

**IMPORTANT:** When changing components ensure that both the gas and electrical supplies to the boiler are isolated before any work is started.

See Section 10.0 “Annual Servicing” for removal of case panel, doors etc.

**11.1 Pressure Switch (Fig. 49)**

1. Note the positions of the two sensing tubes and three wires and remove them.
2. Undo the screws securing the pressure switch to the combustion box bracket and remove the switch.
3. Fit the new component in reverse order of dismantling and connect the sensing tubes and wires as previously noted (see Service Guidance label on reverse of front panel).

**11.2 Fan (Fig. 51)**

1. Note the positions of the two sensing tubes and three wires on the pressure switch and remove them.
2. Undo the screws securing the pressure switch to the combustion box bracket and remove the switch.
3. Remove the screws from the flue adaptor clamp. Prise the clamp apart and disengage it from the fan outlet adaptor and boiler flue adaptor. Remove the clamp.
4. Note the positions of the three wires on the fan motor and remove them. Remove the two screws securing the flue hood forward edge.
5. Draw the fan and hood assembly forwards out of the combustion box.
6. Undo the two screws securing the fan to the fan hood and remove the fan by disengaging the tabs from the slots in the hood.
7. Undo the two screws securing the outlet adaptor to the fan. Transfer the adaptor to the new fan.
8. Fit the new fan to the hood and reassemble in reverse order.

**11.3 Burner (Fig. 52)**

1. Undo the screws securing the combustion box inner panel and remove. Disconnect the gas supply from the burner inlet manifold and remove the two electrode leads from the burner.
2. Draw the burner forwards out of the combustion box and disconnect the flame sensing lead. Take care not to damage or lose the sealing washer on the gas inlet flange.
3. Undo the screws securing the injector manifold to the burner assembly and remove the manifold.
4. Undo the screws securing the electrodes to the burner assembly and remove them.
5. Fit the electrodes and injector manifold to the new burner and check the electrode positions. Reassemble in reverse order.

### 11.4 Gas Valve (Fig. 54)

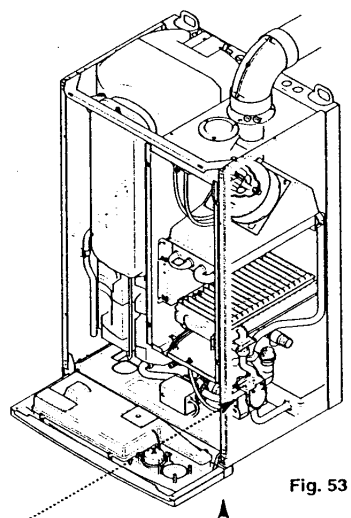

Fig. 53

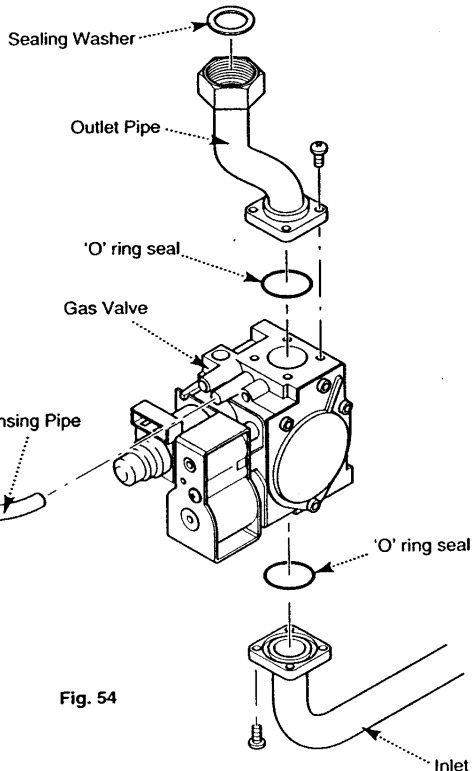
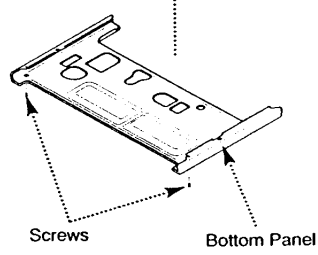

Fig. 54

1. Undo the two screws securing the outercase bottom panel and remove the panel (Fig. 53).
2. Disconnect the wires from the valve coil and the pressure sensing tube from the valve.
3. Undo the screw securing the solenoid plug to the valve. Disconnect the plug.
4. From beneath the appliance undo the four screws securing the gas inlet pipe manifold to the valve.
5. Undo the screws securing the combustion box front panel. Remove the panel, being careful not to damage the seal.
6. Pull the sensing pipe off the spigot on the gas valve.
7. Disconnect the gas supply from the burner inlet manifold taking care not to damage the sealing washer. Remove the pipe grommet from the combustion box lower panel.
8. Carefully manoeuvre the gas valve and outlet pipe from the appliance, taking care not to damage the 'O' ring seal in the gas inlet pipe manifold. If necessary remove the gas inlet pipe from the pipe bracket.
9. Undo the four screws securing the gas outlet pipe manifold to the valve. Remove the outlet pipe taking care not to damage the 'O' ring seal in the outlet pipe manifold.
10. Examine the 'O' ring seals and replace them if necessary. Reassemble in reverse order, ensuring that the washer is in place between the gas supply and the burner inlet manifold. Replace the washer if it is damaged in any way.
11. Ensure that the gas pipe grommet is correctly located in the combustion box lower panel.
12. Check the burner pressures, and re-commission the boiler.

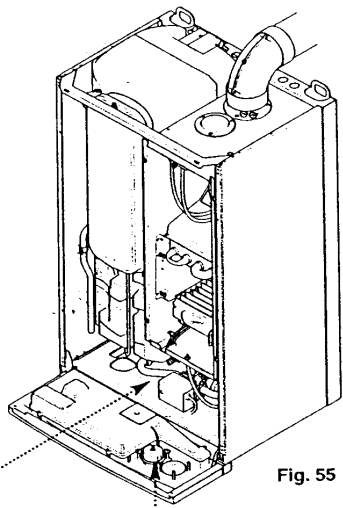

Fig. 55

**11.5 Pressure Gauge (Figs. 55, 56 & 57)**

1. Hinge the fascia panel downwards and undo the two screws retaining the control box. Lower the control box.
2. Drain the primary circuit.
3. Undo the nut on the pressure gauge capillary from the manifold and remove the screws securing the gauge retaining bracket.
4. Remove the bracket and gauge assembly. Depress the barbs on the side of the gauge and remove the retaining bracket.
5. Reassemble in reverse order, re-pressurising the system if necessary.

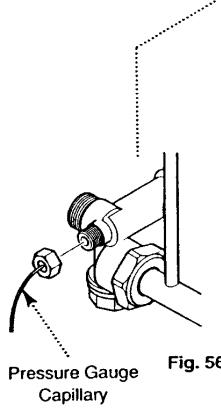

Fig. 56

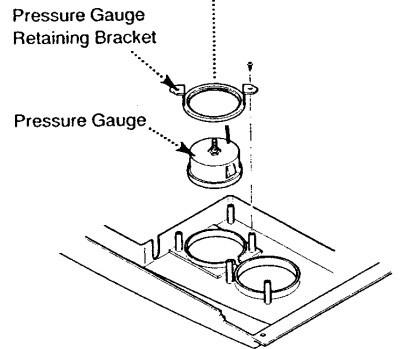

Fig. 57

**11.6 Heat Exchanger (Figs. 58 & 59)**

1. Remove the fan and hood assembly as described in Changing Components Section 11.2, paragraphs 1 to 5.
2. Carefully draw the side insulation pieces out, taking care not to damage them. Ease the heat exchanger sideways while extracting each piece.
3. Undo the two retaining screws on the heat exchanger rear flanges. Pull the heat exchanger forwards, disengaging the flow and return spigots from the pipe fittings.
4. Reassemble in reverse order, ensuring that the rear insulation piece is in place and the cut outs in the side pieces are at the bottom and to the rear.
5. Re-commission the appliance.

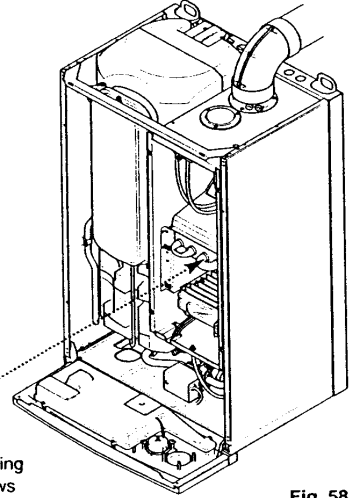

Fig. 58

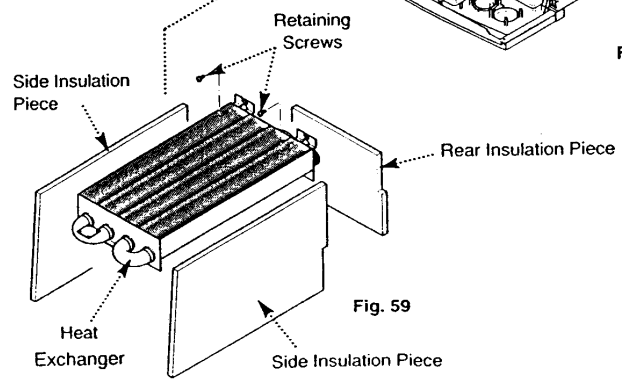

Fig. 59

### 11.7 Insulation (Figs. 60 & 61)

There are four insulation pieces in the combustion box - two side pieces, one rear and one front attached to the combustion box inner panel.

#### Side Pieces

1. Remove the screws securing the fan hood. Carefully draw the side insulation pieces out, easing the heat exchanger sideways while extracting each piece.
2. To replace, ease the heat exchanger sideways and very carefully insert each piece. Ensure that the replacement insulation is not abraded against the heat exchanger or captive nuts.

#### Rear Piece

1. To change the rear piece it is necessary to remove the heat exchanger as described in Section 11.6.
2. The rear piece is retained by the heat exchanger. Ensure that the replacement piece is correctly positioned before refitting the heat exchanger.

#### Front Piece

1. The front piece is attached to the combustion box inner panel. To replace, disengage it from the retaining tabs on the lower edge of the inner door.
2. Fit the new insulation piece by carefully locating it behind the tabs and pushing back.

#### Completion

Carefully clean away any insulation from the combustion box and reassemble in reverse order.

### 11.8 Temperature Sensors (Figs. 62 & 63)

1. The temperature sensors on the store and flow pipe are of the same type and the replacement procedure is the same.
2. Ease the retaining tab on the sensor away and disconnect the electrical plug.

3. Unscrew the sensor from it's pocket. Fit the new sensor and reassemble in reverse order. The plug will only fit one way.

### 11.9 Overheat Thermostat (Figs. 62 & 64)

1. Pull the two electrical connections off the thermostat.
2. Remove the screws securing the thermostat to the mounting plate on the flow pipe.

3. Reassemble in reverse order. The thermostat is not polarised - either wire can fit either terminal on the thermostat.

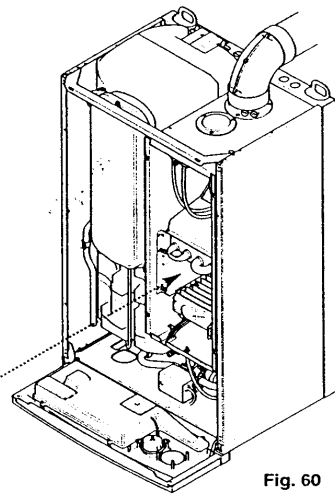

Fig. 60

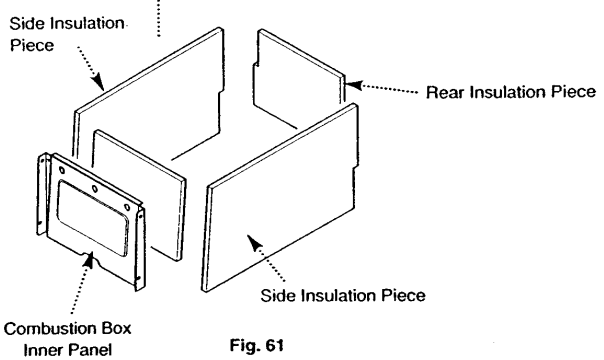

Fig. 61

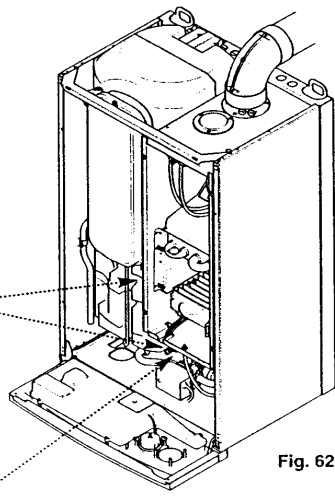

Fig. 62

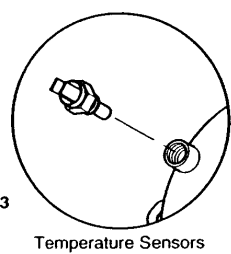

Fig. 63

Temperature Sensors

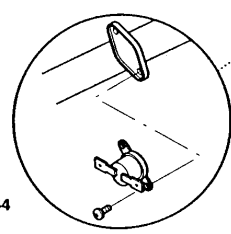

Fig. 64

Overheat Thermostat

### 11.10 Circuit Boards & Electrical Components

(Figs. 65 & 66)

See section 12.0 "Illustrated Wiring Diagram" for the layout of all electrical components. To gain access hinge the facia panel down and remove the screws securing the control box. Lower the control box. Undo the screws securing the control box cover, lift the cover upwards and allow it to rest against the appliance.

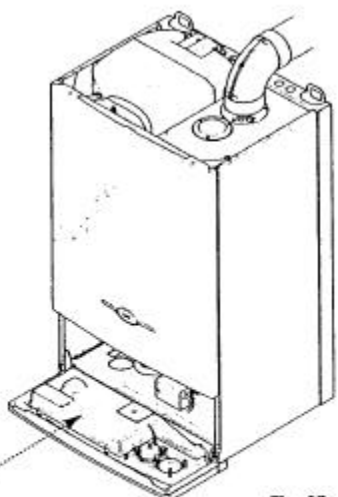

Fig. 65

#### Neon PCB

1. Undo the screw securing the neon PCB to the control panel and disconnect the plug on the ribbon wiring from the PCB.

2. Reassemble in reverse order.

#### Main PCB

1. Note the position of each plug and connector and remove them. Remove the PCB securing screws.

2. Carefully draw the PCB away from the control panel, disengaging it from the control knob spindles.

3. Take the new PCB and establish the position of the drive slots in the temperature control potentiometers and mode selector switch. Position the knobs such that their shafts will align with the slots and carefully fit the new board.

4. Reconnect all plugs and connectors previously removed and reassemble in reverse order.

#### Relay PCB

1. Disconnect the plug from the PCB and undo the screw securing the PCB to the control panel.

2. Reassemble in reverse order.

#### Ignition PCB

1. Note the position of each plug and connector including the earth wire and remove them.

2. Undo the PCB securing screws and remove the board.

3. Reassemble in reverse order.

#### Suppressor

**IMPORTANT: The new suppressor must be wired as shown to ensure correct operation of the boiler.**

1. Ease the suppressor out of the clips on the inner face of the control panel cover.

2. Remove each wire from the original suppressor, one at a time and connect it to the appropriate terminal on the new suppressor before disconnecting any further wires.

3. Locate the new suppressor in the clips on the inner face of the control panel cover and reassemble in reverse order.

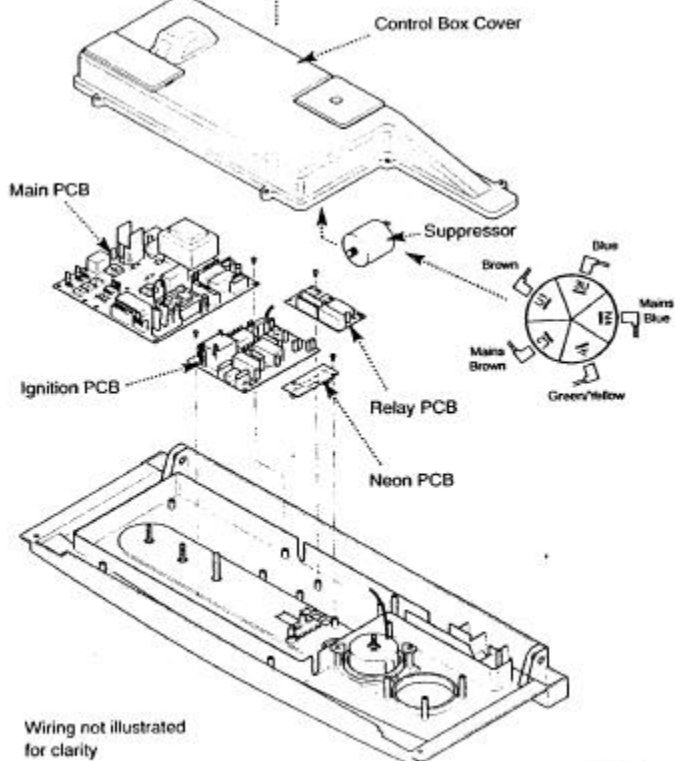
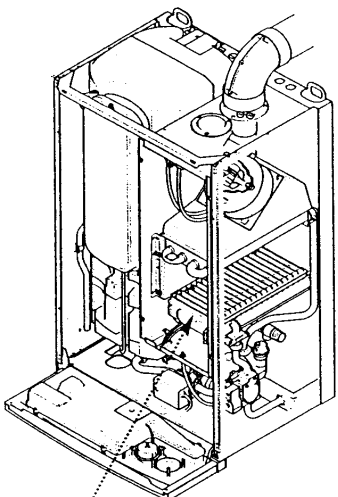

Fig. 66

Wiring not illustrated for clarity

Fig. 67



Spark Electrodes

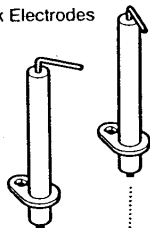

Sensing Electrode

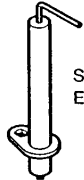

Fig. 68

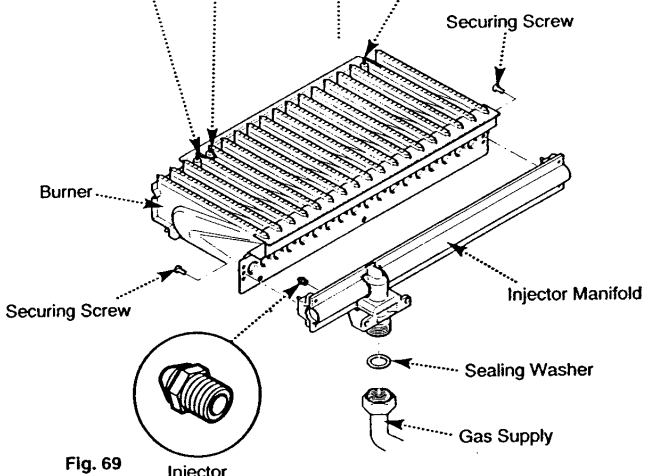

Fig. 69

Injector

Reducing Valve Cartridge

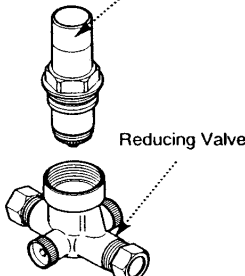

Fig. 70

Expansion Relief Valve Cartridge

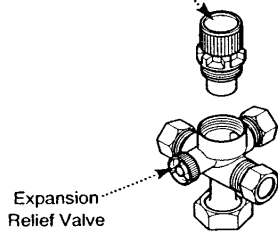

Fig. 71

**11.11 Electrodes (Fig. 68)**

1. Remove the burner as described in section 11.3 and undo the screw securing the relevant electrode to the burner assembly and remove.
2. Check the electrode positions and reassemble in reverse order.

**11.12 Injectors (Fig. 69)**

1. Remove the burner as described in section 11.3 and undo the screws securing the injector manifold to the burner assembly and remove the manifold.
2. Unscrew and replace injectors as required and reassemble in reverse order.

**11.13 Pressure Reducing Valve Cartridge (Fig. 70)**

1. Turn off the mains water supply and drain down the domestic hot water storage tank.
2. Unscrew the cartridge from the valve body and discard.
3. Reassemble in reverse order.

**11.14 Expansion Relief Valve Cartridge (Fig. 71)**

1. Turn off the mains water supply and drain down the domestic hot water storage tank.
2. Unscrew the cartridge from the valve body and discard.
3. Reassemble in reverse order.

### 11.15 Diverter Valve- Head Only (Fig. 73)

1. Disconnect the three pin plug on the valve electrical input cable from the boiler wiring loom.
2. Slacken the screw securing the valve operating head cover. Pull the cover forwards to remove.
3. Undo the two screws retaining the operating head to the valve body and draw the head forwards.
4. Reassemble in reverse order.

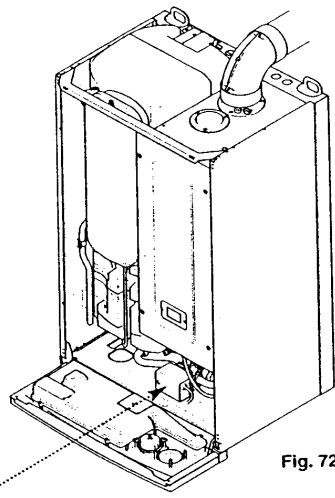

Fig. 72

### 11.16 Diverter Valve - Complete (Fig. 74)

1. Disconnect the three pin plug on the valve electrical input cable from the boiler wiring loom.
2. Drain the primary circuit.
3. Slacken the screws securing each washer and pipe flange to the valve. Rotate the washers and disengage them from the screw heads.
4. Undo the water storage feed pipe nut at the adaptor on the base of the tank. Remove the pipe by easing it out of the valve body, taking care not to damage the "O" ring seal or washer.
5. Disconnect the valve from the remaining pipes, taking care not to damage the "O" ring seals. Remove the screws from the body and engage them in the new component.
6. Reassemble in reverse order.

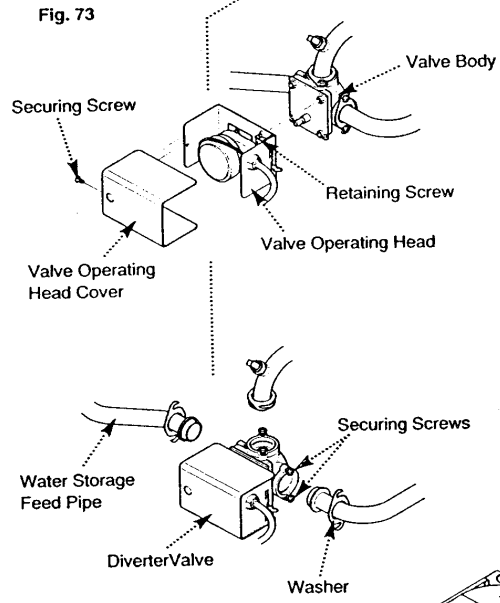

Fig. 73

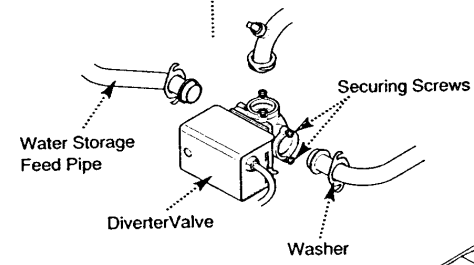

Fig. 74

### 11.17 Differential Pressure Switch (Fig. 76)

1. Remove the spring clip securing the switch sensing head to the switch body. Draw the head off the body.
2. Drain the primary circuit.
3. Undo the nuts on each pipe at the body of the pressure switch and remove it.
4. Reassemble in reverse order.

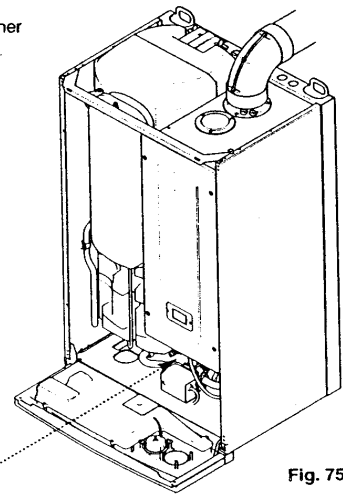

Fig. 75

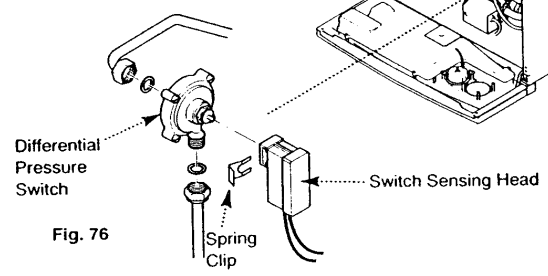
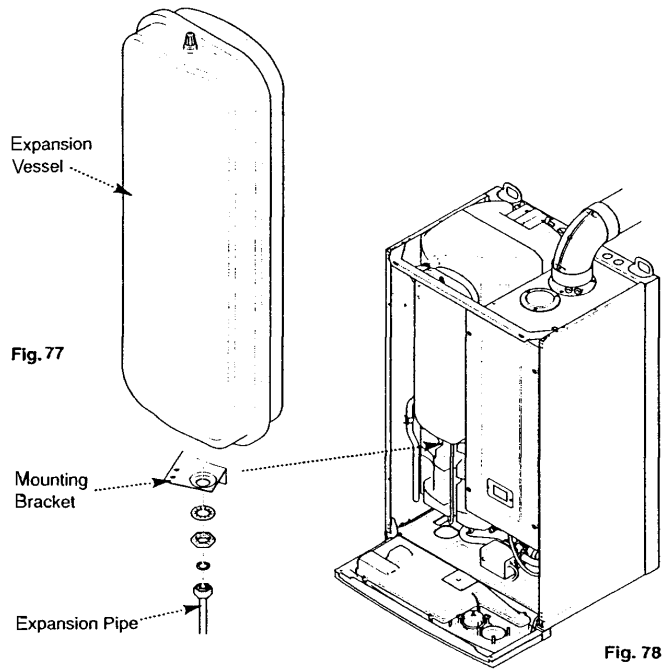

Fig. 76

### 11.18 Expansion Vessel (Fig. 77)

1. Drain the primary circuit and undo the nut on the expansion pipe at the adaptor on the bottom of the vessel.
2. Undo the nut and washer securing the vessel to the mounting bracket on the side of the storage tank.
3. Lift the vessel slightly to disengage the adaptor from the mounting bracket. Remove the vessel from the appliance.
4. Reassemble in reverse order.



### 11.19 Storage Tank Temperature & Pressure Relief Valve (Fig. 79)

1. It is necessary to remove the expansion vessel as described in 11.18 prior to changing the relief valve.
2. Undo the nut on the discharge pipe at the valve and ease the pipe out of its retaining clip on the case side.
3. Undo the nut on the temperature and pressure relief valve securing it to the spigot on the storage tank and remove the valve.
4. Ensure that the sealing washer is in place and fit the new valve. Reassemble in reverse order.

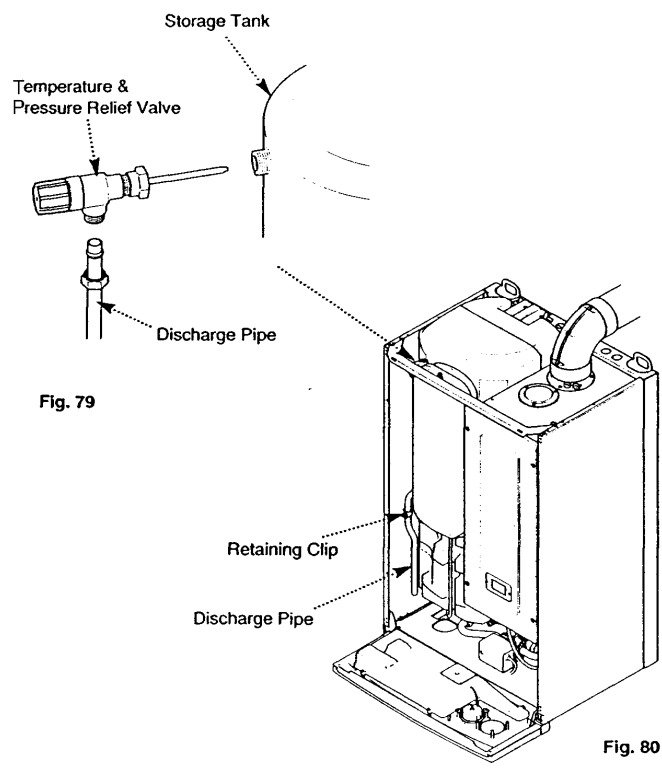

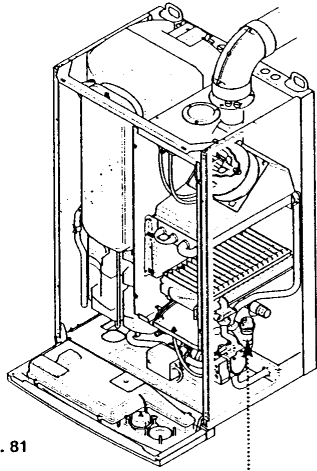

Fig. 81

**11.20 Pump - Head Only** (Figs. 82 & 83).

1. Drain the primary circuit and remove the socket head screws securing the pump head to the body and draw the head away.
2. Undo the screw on the pump wiring cover and remove the cover. Using a suitable flat bladed screwdriver press the cable securing levers downwards to release each wire after noting their position.
3. A standard Grundfos 15-60 replacement head can now be fitted. Connect the wiring to the new head. **The pump speed must be set to 3.**
4. Reassemble in reverse order.

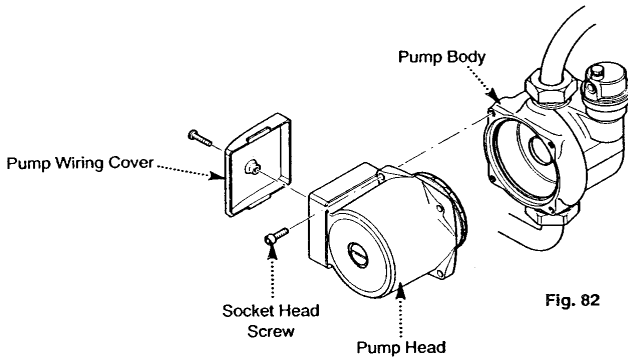

Fig. 82

**11.21 Pump - Complete** (Figs. 83 & 84).

1. Drain the primary circuit and unscrew the automatic air vent from the pump body. Undo the union nuts on the inlet and outlet connections and draw the pump forwards.
2. Undo the screw on the pump wiring cover and remove the cover. Using a suitable flat bladed screwdriver press the cable securing levers downwards to release each wire after noting their position.
3. Connect the wiring to the new head and **set the pump speed to 3.** Using new sealing washers fit the new pump, fit the air vent to the pump body and reassemble in reverse order.

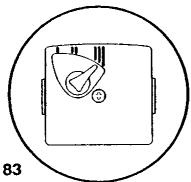

Fig. 83

Pump Setting

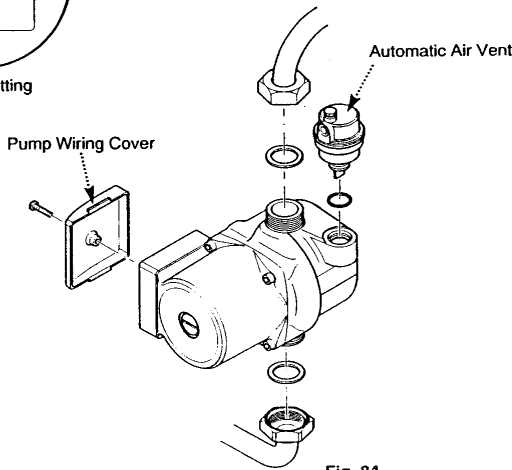
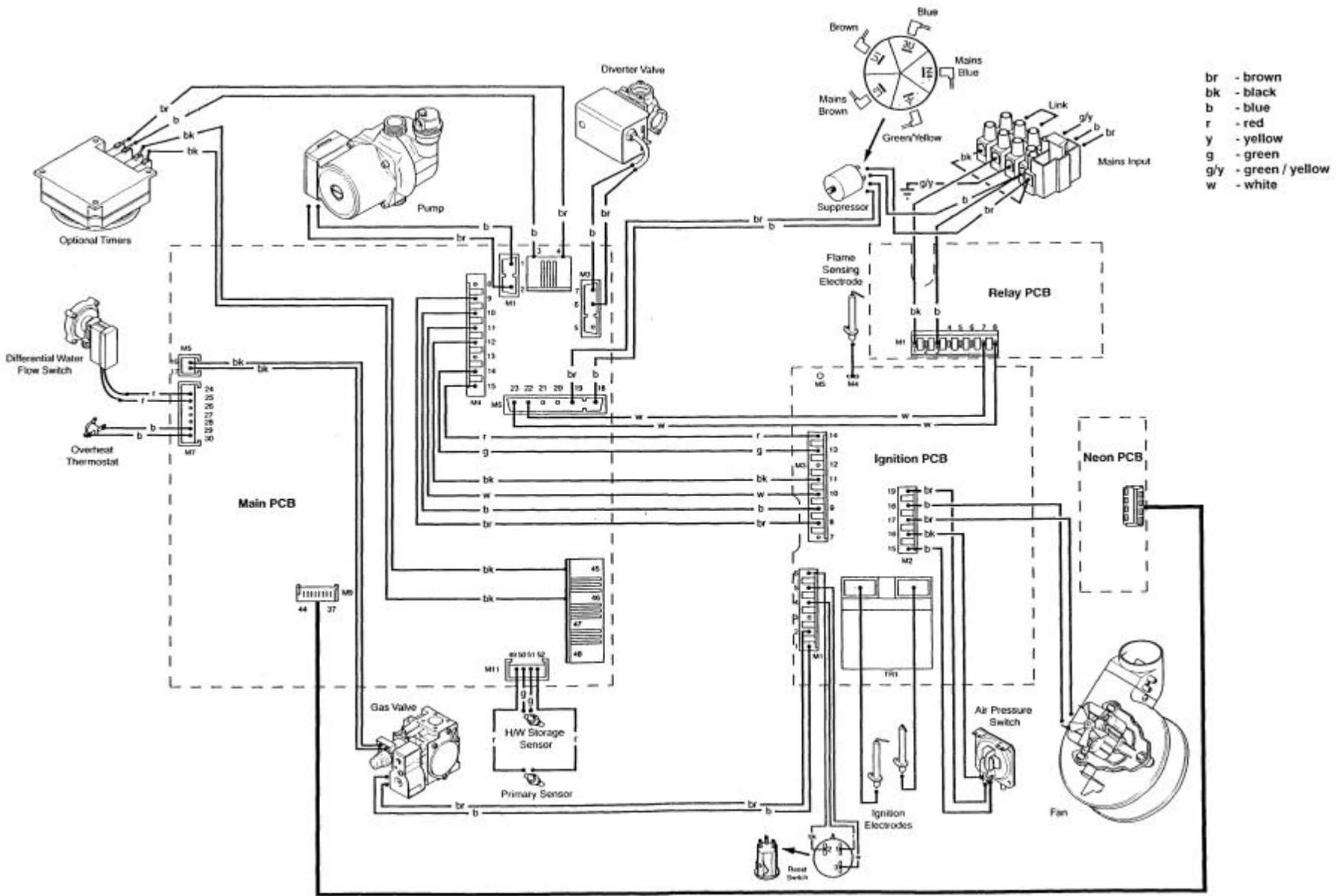

Fig. 84

**11.22 Automatic Air Vent** (Fig. 84)

1. Drain the primary circuit and unscrew the automatic air vent from the pump body.
2. Examine the "O" ring seal, replacing if necessary, and fit it to the new automatic air vent.
3. Reassemble in reverse order, re pressurising the system if necessary.

2.0 Illustrated Wiring Diagram – Page 36 to 37



# 13.0 Fault Finding – Page 38

## Carry out initial fault finding checks

1. Check that gas, water and electrical supplies are available at the boiler. Electrical supply = 230V - 50 Hz.  
CH water system pressurised to 0.5 bar when the boiler is cold. The preferred minimum gas pressure is 19.5mbar (natural gas), 27mbar (butane) or 36mbar (propane).
2. Carry out electrical system checks, i.e. Ground Continuity, Resistance to Ground, Short Circuit and Polarity with a suitable meter.  
Note: These checks must be repeated after any servicing or fault finding.
3. Ensure all external controls are calling for heat and check all external and internal fuses. Before any servicing or replacement of parts ensure the gas and electrical supplies are isolated.

Refer to Section 13.0 "Illustrated Wiring Diagram" for position of numbered terminals  
**Central Heating** - Follow operational sequence

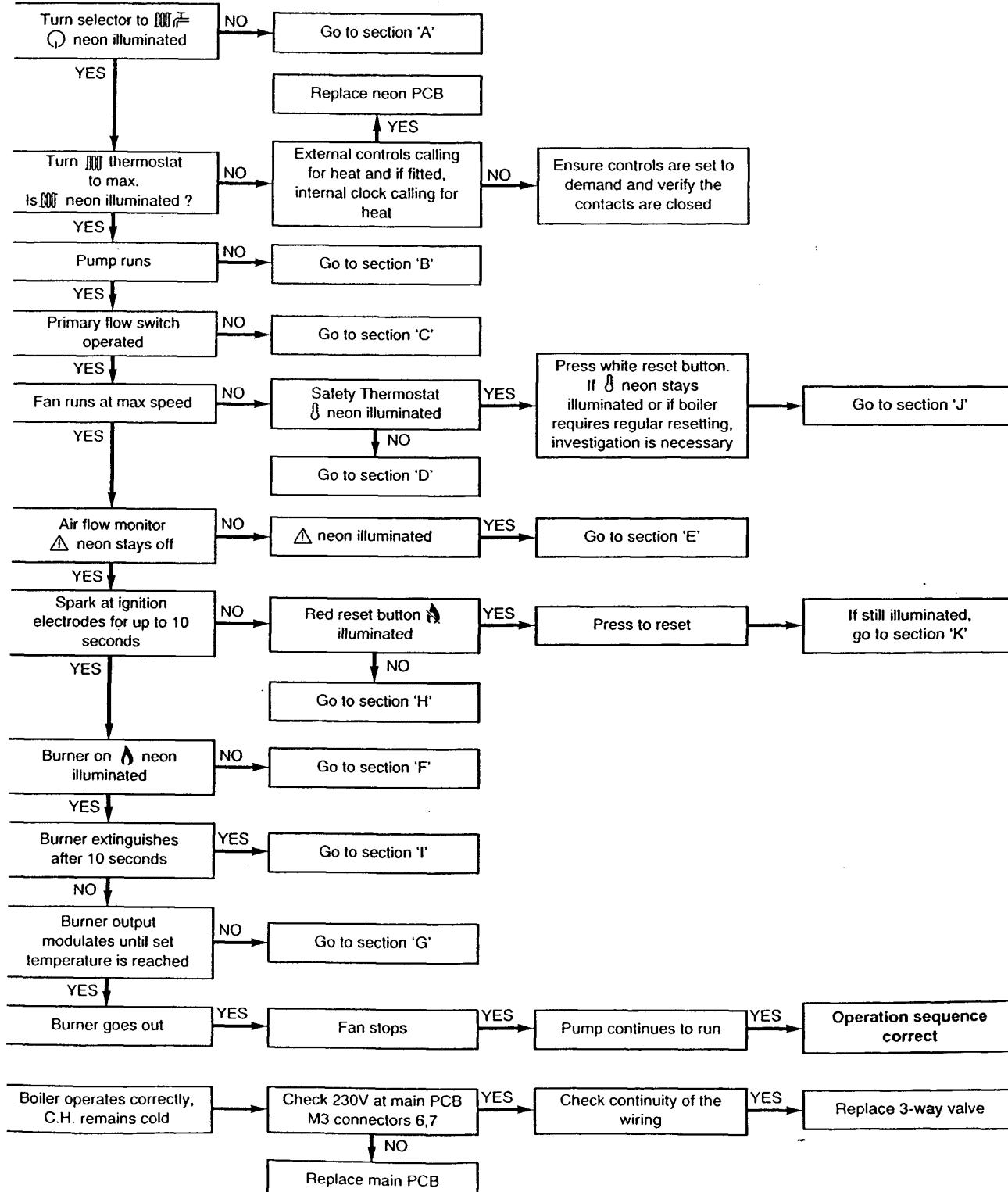

# 13.0 Fault Finding – Page 39

Domestic Hot Water - Follow operational sequence (DHW storage at ambient temperature i.e. cold)

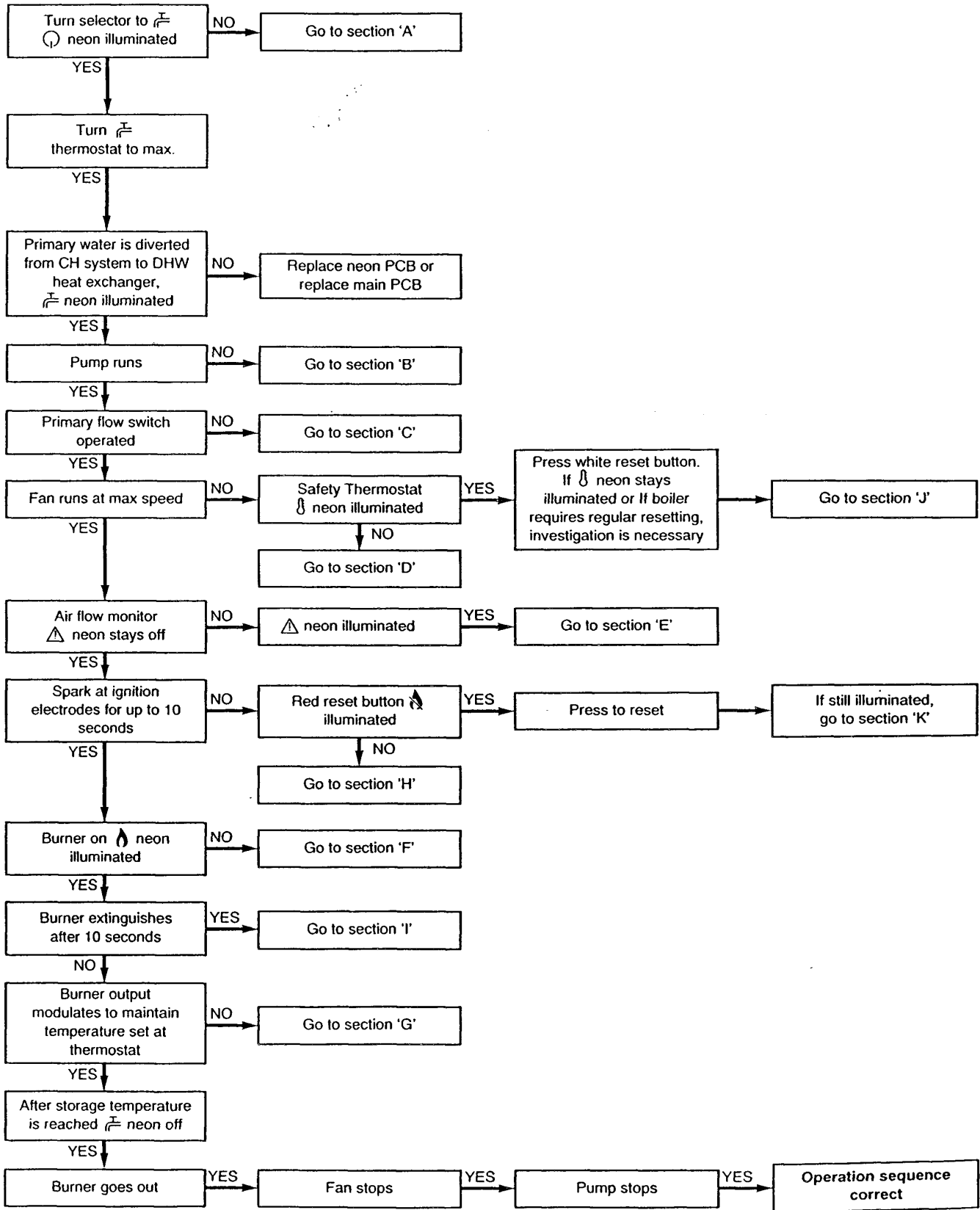

### 13.0 Fault Finding – Page 40

#### Fault Finding Solutions

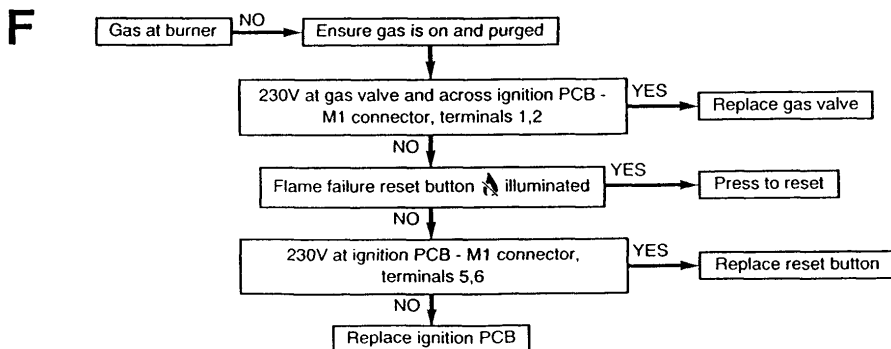
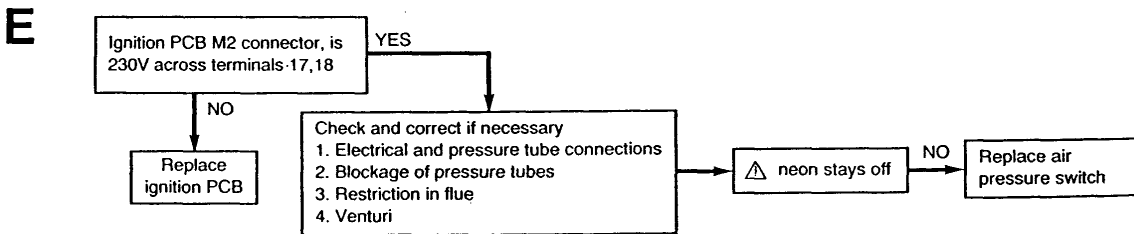
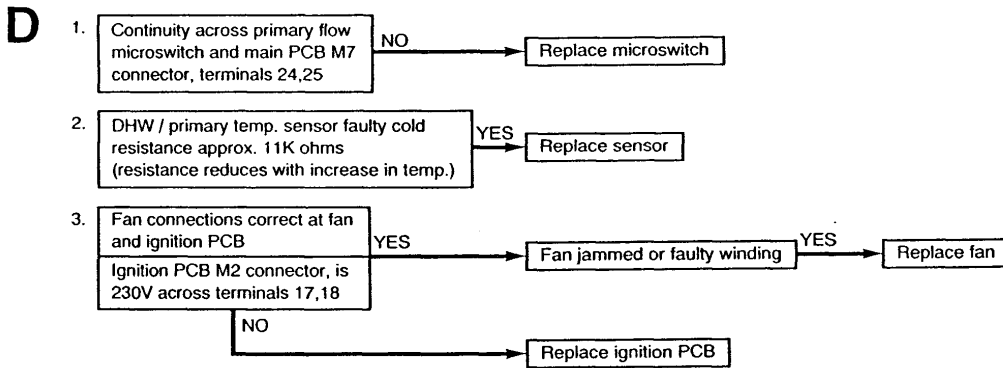
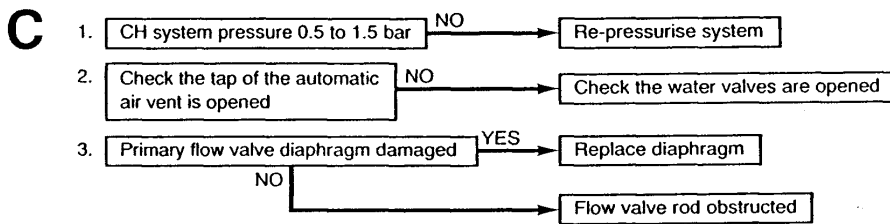
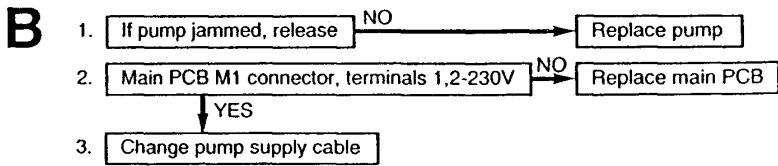
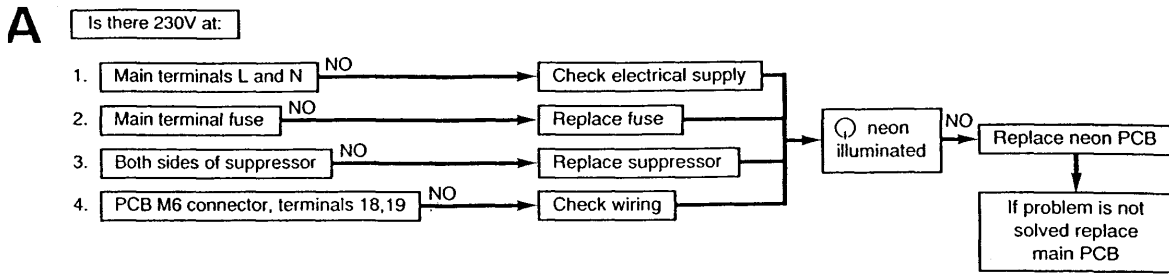

13.0 Fault Finding – Page 41

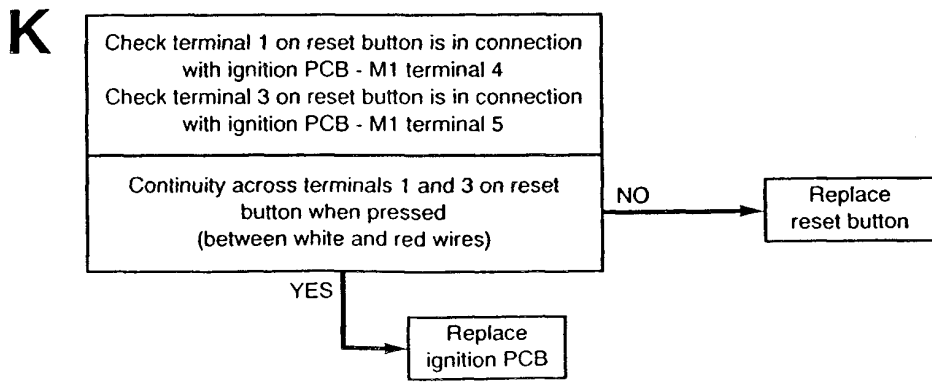
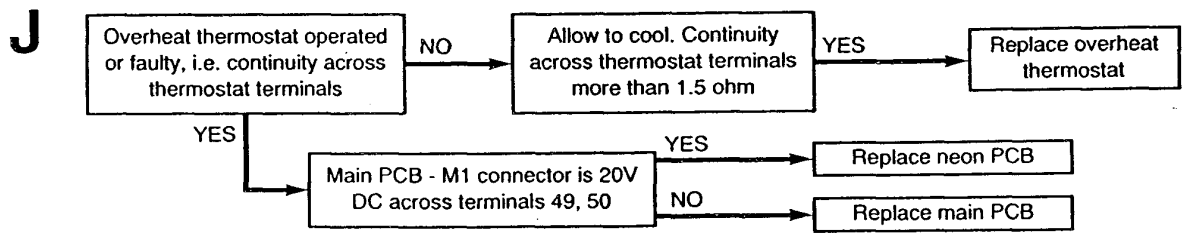
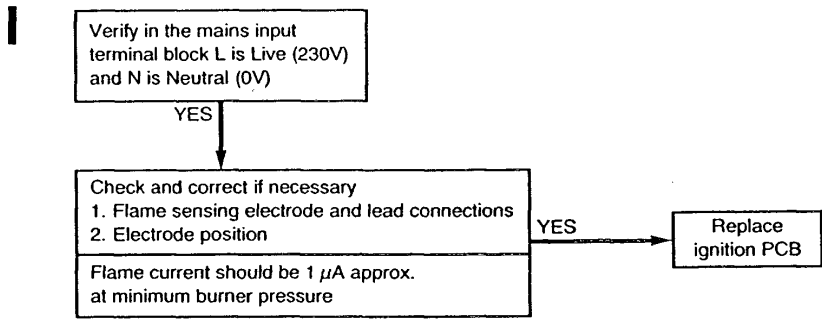
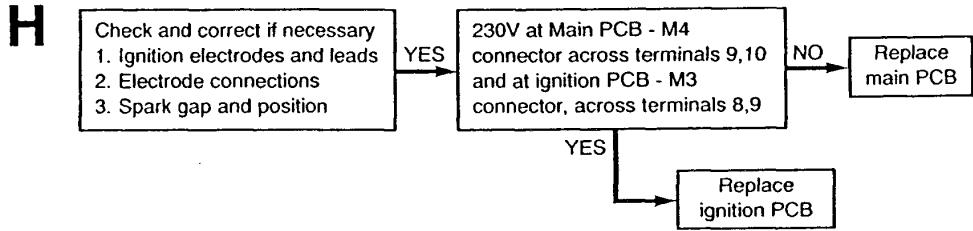
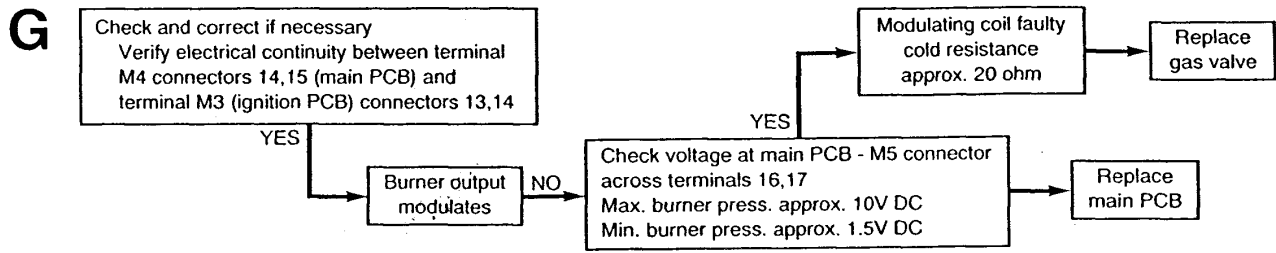

# 14.0 Short Parts List – Page 42

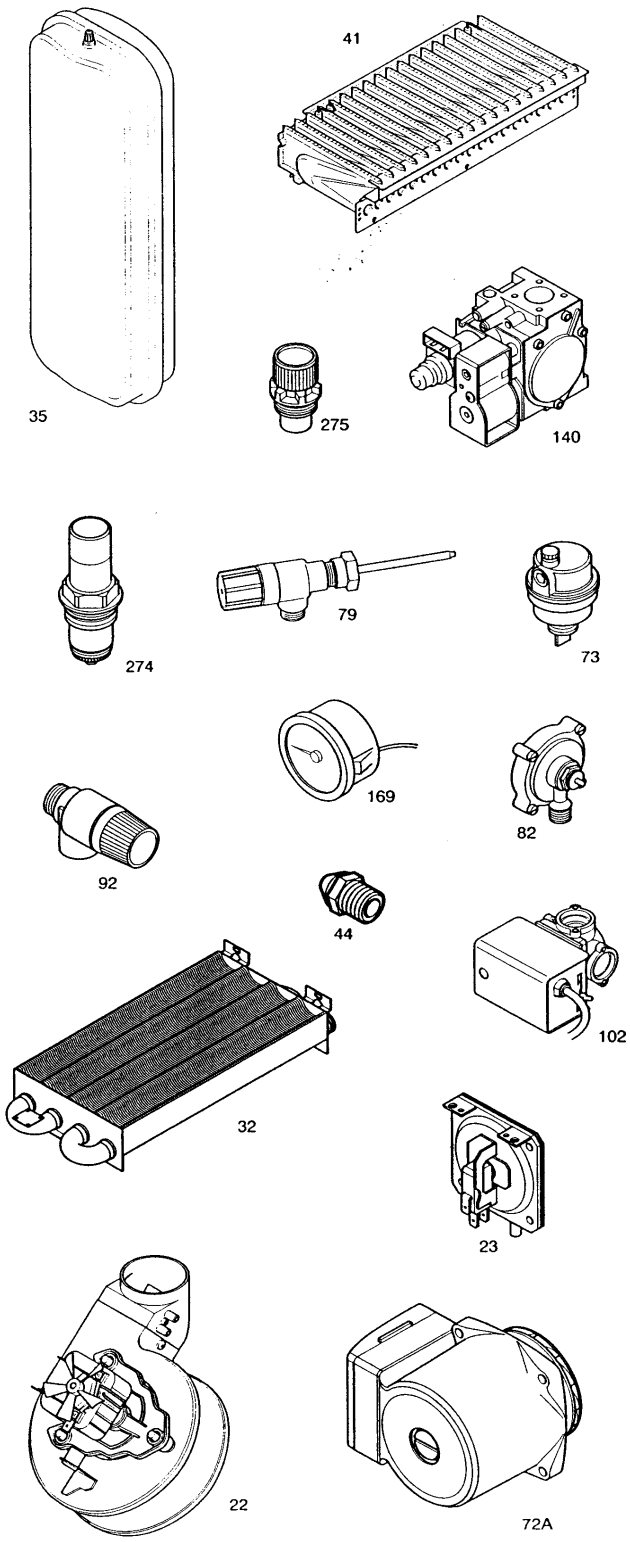

## Short Parts List

Key No.	G.C. No.	Description	Manufacturers Part No.
23	393-947	Pressure Switch.	247380
22	378-864	Fan	247381
41	343-786	Burner	247387
82	E03-572	Pressure Differential Switch	247388
72A		Pump Head	247390
73	379-796	Automatic Air vent	247391
140		Gas valve	247392
102		Diverter valve (3 Port Valve)	247395
169	385-839	Pressure Gauge	247396
92		Safety Valve 3bar	247402
274		Cartridge Pressure Reducing Valve	247403
275		Cartridge Expansion Relief Valve	247404
79		Storage Temp/Pressure Relief Valve	247405
32		Heat Exchanger	247428
35		Expansion vessel	247431
44		Burner Injector	

### 14.0 Short Parts List – Page 43

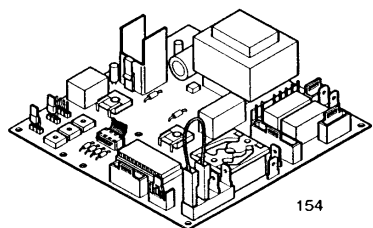
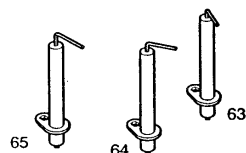
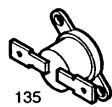
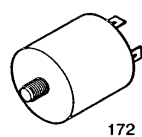
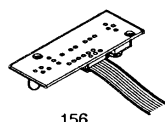
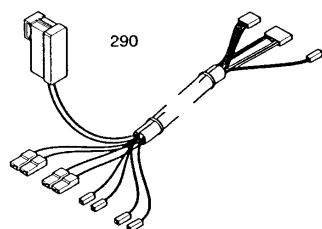
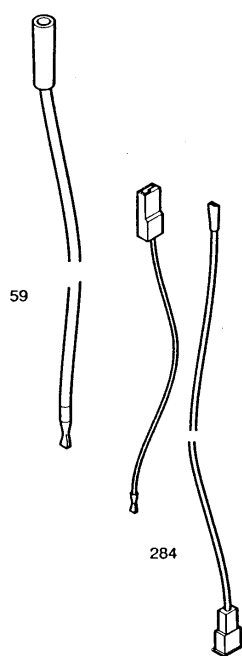
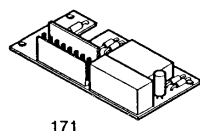
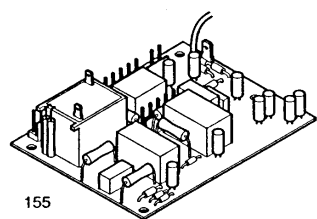

### Short Parts List

Key No.	G.C. No.	Description	Manufactures Part No.
65		Electrode Sensing	247382
63		Electrode Ignition Rear	247383
64		Electrode ignition Front	247384
59		Electrode Lead Ignition	247385
284		Electrode Lead Sensing	247386
290		Microswitch Loom	247389
135		Limit Thermostat (O/Heat)	247393
131	343-571	Temperature Sensor	247394
172	379-764	Capacitor	247397.
154		Main PCB	247398
155		Ignition PCB	247399
156		Neon PCB	247400
171	343-718	Relay PCB	247401

[Click here for Helplines](#)