

Baxi Windermere

Baxi Grasmere

Gas Stoves

Comp N° 242300 - Iss 5 - 5/00

Installation and Servicing Instructions

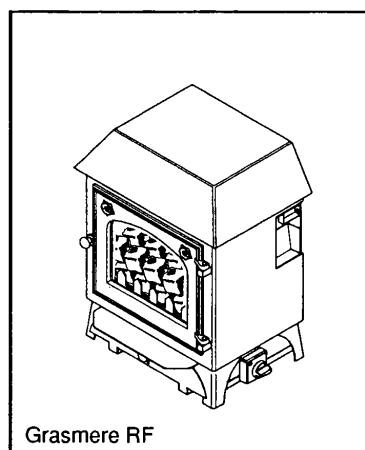
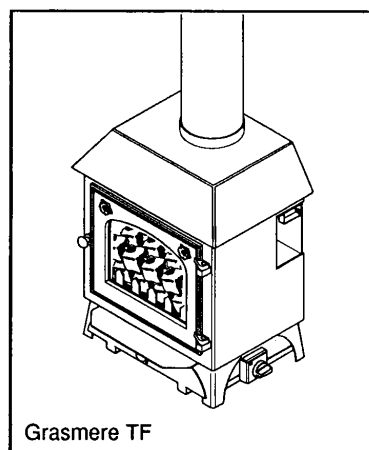
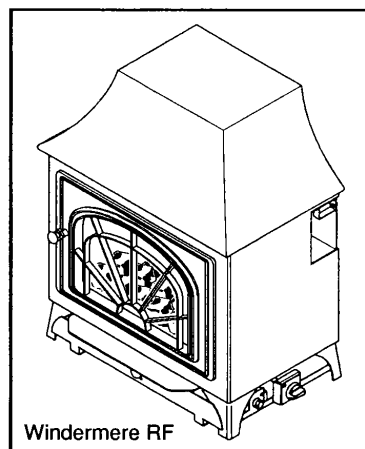
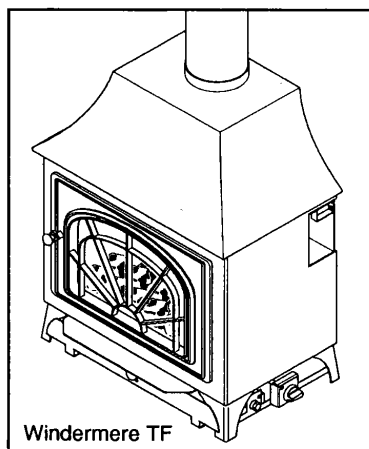

THIS DOCUMENT HAS BEEN PROVIDED BY
heatingspares247.com
PLEASE VISIT WWW.HEATINGSPPARES247.COM FOR FURTHER INFORMATION AND GENUINE PARTS & SPARES AT LOW PRICES

BAXI

Natural Gas

Baxi Windermere RF
G.C.No 32 075 26

Baxi Windermere TF
G.C.No 32 075 27

Baxi Grasmere RF
G.C.No 32 075 24

Baxi Grasmere TF
G.C.No 32 075 25

Baxi UK Limited is one of the leading manufacturers of domestic heating products in the UK.

Our first priority is to give a high quality service to our customers. Quality is built into every Baxi product -products which fulfil the demands and needs of customers, offering choice, efficiency and reliability.

To keep ahead of changing trends, we have made a commitment to develop new ideas using the latest technology - with the aim of continuing to make the products that customers want to buy.

Baxi is also the largest manufacturing partnership in the country. Everyone who works at the company has a commitment to quality because, as shareholders, we know that satisfied customers mean continued success.

We hope you get a satisfactory service from Baxi. If not, please let us know.



Baxi is a BS-EN ISO 9001
Accredited Company

Propane Gas

Baxi Windermere RF
G.C.No 32 075 28

Baxi Windermere TF
G.C.No 32 075 29

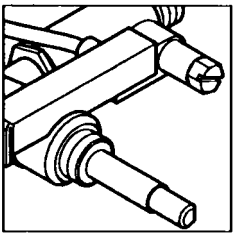
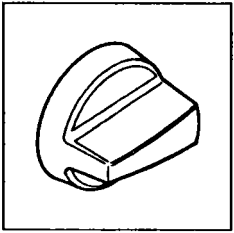
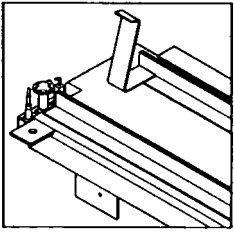

Section	Page
1.0 Introduction	4
2.0 Technical Data	5
3.0 Site Requirements	6
4.0 Installation	9
5.0 Arranging the Coals	11
6.0 Commissioning the Stove	13
7.0 Checking for Spillage	14
8.0 Completion	15
9.0 Annual Servicing	16
10.0 Changing Components	20
11.0 Fault Finding	23
12.0 Short Parts List	24
13.0 Propane Models	25

The following items are packed with the appliance:-

- Literature
- Controls Cover
- Coal Pieces (Windermere 2 types)
(Grasmere 3 types)
- Ceramic
- Closure Plate (All RF models)
- Coal Guard (Grasmere only)

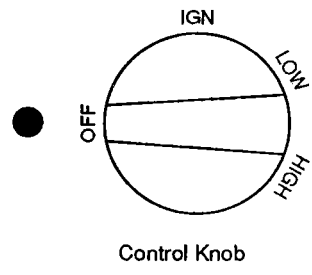
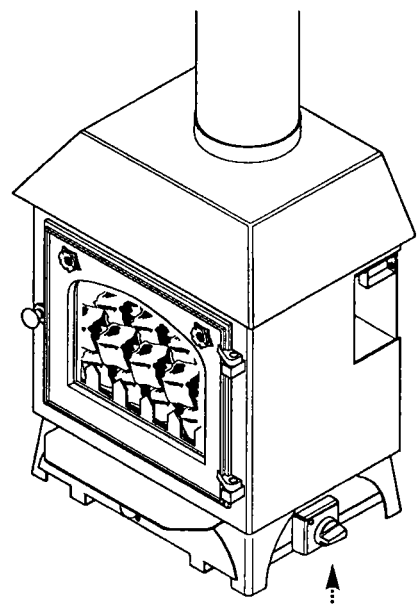

Fig. 1

1.1 Description

1. The Baxi Windermere RF and TF and Grasmere RF and TF are gas fired stove - style appliances with heat inputs of 8.17 kW (27,876 Btu/h) and 6.5 kW (22,178 Btu/h) respectively at maximum setting. They are designed to be used on Natural Gas only at a setting pressure of 20mbar on an installation with a governed meter. The appliances are intended for heating and decorative purposes.
2. For details of Propane appliances see section 13.0 Propane Models.
3. They incorporate a safety feature in the form of a spillage monitoring system which must not be adjusted or bypassed.
4. The stove is controlled by a knob which is positioned at the lower right hand side of the appliance (Fig1). The knob has four positions:
OFF IGN LOW HIGH
5. The pilot will be lit at IGN.

1.2 Installation

1. Prior to installation, ensure that the local distribution condition (identification of the type of gas and pressure) and the adjustment of the appliance are compatible.
2. The appliance is suitable for installation only in GB. and I.E. and should be installed in accordance with the rules in force. For Ireland install in accordance with I.S.813 "INSTALLATION OF GAS APPLIANCES". The installation must be carried out by a CORGI Registered Installer or other competent person and be in accordance with the relevant requirements of the current **GAS SAFETY** (Installation and Use) **REGULATIONS** (as amended), the **BUILDING REGULATIONS** issued by the Department of the Environment, **BUILDING STANDARDS** (Scotland) (Consolidation) **REGULATIONS** issued by the Scottish Development Department and the **LOCAL BUILDING REGULATIONS**. Where no specific instructions are given, reference should be made to the relevant **BRITISH STANDARD CODES OF PRACTICE**.
2. **This appliance must be installed in accordance with the manufacturers instructions and the rules in force and only used in a suitably ventilated location.**
3. **Read the instructions before installing or using this appliance.**

1.3 Important Information

This product contains Refractory Ceramic Fibres (R.C.F.) which are man-made vitreous silicate fibres. Excessive exposure to these materials may cause temporary irritation to eyes, skin and respiratory tract. Care must be taken when handling these articles to ensure the release of dust or fibres is kept to a minimum.

To ensure that the release of fibres from these articles is kept to a minimum, during installation and servicing it is recommended that a H.E.P.A. filtered vacuum is used to remove any dust, soot or other debris accumulated in and around the appliance. This should be performed before and after working on the installation.

It is recommended that any replaced item(s) are not broken up but sealed within heavy duty polythene bags and clearly labelled "R.C.F. waste". This is not classified as 'hazardous waste' and may be disposed of at a tipping site licensed for the disposal of industrial waste.

Protective clothing is not required when handling these articles but it is recommended that gloves are worn and the normal hygiene rules of not smoking, eating or drinking in the work area are followed and always wash hands before eating or drinking.

Notice

Discolouration of wall surfaces

Most heating appliances generate warm air convection currents and transfer heat to any wall surface against which they are situated.

Some soft furnishings (such as blown vinyl wallpapers) may not be suitable for use where they are subject to temperatures above normal room levels and the manufacturer's advice should be sought before using this type of wall covering adjacent to any heating appliance.

The likelihood of wall staining from convected air currents will be increased in environments where high levels of tobacco smoke or other contaminants exist.

Grasmere		
Category of Appliance I _{2H} The stove is set for Gas Type G20 at 20mbar.		
Heat Input	High	Low
kW	6.5	5
Btu/h	22,178	17,060
Heat Output	High	
kW	4.96	
Btu/h	16,922	
Inlet Setting Pressure		Cold
	mbar	9 ± 0.5
	in wg	3.6 ± 0.2
Gas Connection	8mm OD tube, rigid or semi rigid and 8mm compression fitting at appliance inlet	
Controls & Safety system	Rotary gas tap with piezo ignition to pilot. Spillage monitoring system	
Gas Rate	0.63m ³ /h (22.241 ft ³ /h)	
Lifting Weight	RF	TF
	38.2 kg	36.4 kg
Dimensions	Height	555mm (RF)
	Height	580mm (TF)
	Width	450mm
	Depth	345mm
Injector	82/600	

Windermere		
Category of Appliance I _{2H} The stove is set for Gas Type G20 at 20mbar.		
Heat Input	High	Low
kW	8.17	5.6
Btu/h	27,876	19,107
Heat Output	High	
kW	6.14	
Btu/h	20,962	
Inlet Setting Pressure		Cold
	mbar	6.5 ± 0.5
	in wg	2.6 ± 0.2
Gas Connection	8mm OD tube, rigid or semi rigid and 8mm compression fitting at appliance inlet	
Controls & Safety system	Rotary gas tap with piezo ignition to pilot. Spillage monitoring system	
Gas Rate	0.80m ³ /h (24.01 ft ³ /h)	
Lifting Weight	RF	TF
	54.1 kg	51.6 kg
Dimensions	Height	730mm (RF)
	Height	758mm (TF)
	Width	600mm
	Depth	410mm
Injector	82/850	

B.S. Codes of Practice

STANDARD	SCOPE
B.S. 5440: Pts 1 & 2	Flues & Air Supply.
B.S. 1251	Open Fireplace Components
B.S. 5871: Pt 2 & 3	Installation of inset live fuel effect & decorative fuel effect appliances.
B.S. 715	Specification for metal flue pipes, fittings etc.
B.S. 6391	Gas Installation.
B.S. 1289: Pts 1 & 2	Specification for precast & clay flues and terminals.

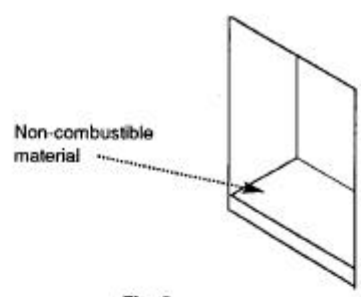

Fig. 2

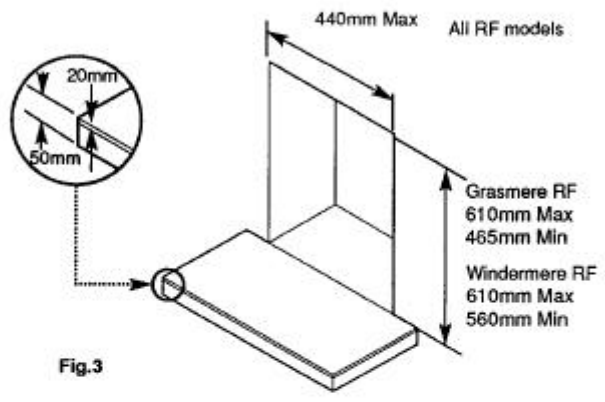

Fig.3

3.1 Fireplace Surround and Hearth

1. A hearth of non-combustible material must be provided within the fireplace opening on which material the stove stands (where applicable) (Fig. 2).
2. A non-combustible hearth must also be provided in front of the fireplace opening. This must be a minimum of 20mm thick, the top surface of the hearth should be a minimum of 50mm above floor level (Fig. 3).
3. The hearth should extend at least 75mm in front of the stove legs and 150mm either side of the stove (Fig. 4).
4. If a fire surround is to be used, it must have a minimum rating of 300° C. Any gaps between the wall and surround must be sealed.
5. **On no account should the stove be fitted directly onto a combustible floor or carpet.**

3.2 Ventilation

Grasmere

1. No purpose provided ventilation is required for the appliance, normal adventitious room ventilation being sufficient.

Windermere

1. A permanent air vent of 100cm² minimum is required. The permanent vent may be directly into the room in which the appliance is installed, or to an adjacent room which has a vent to outside of at least the same area.

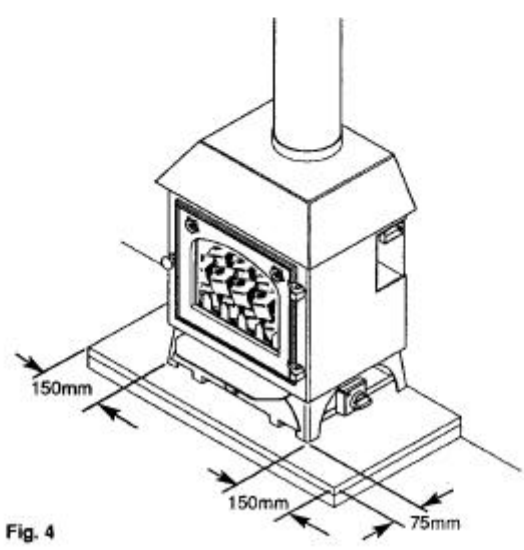

Fig. 4

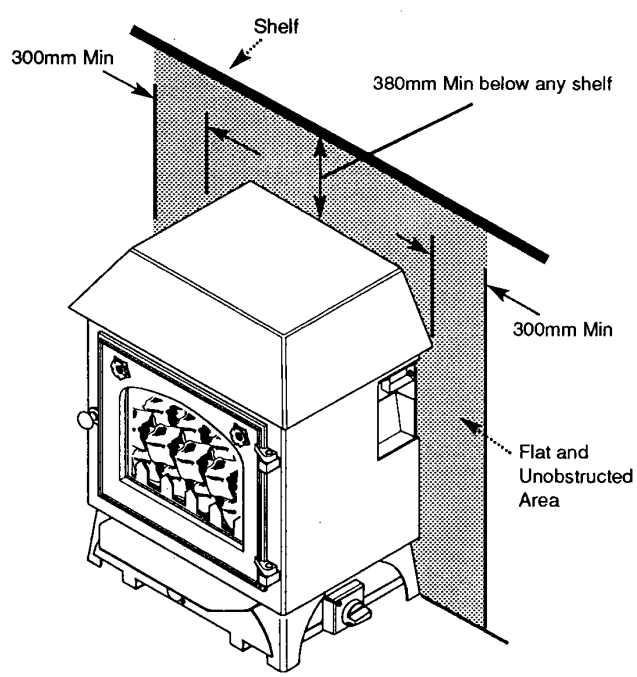

Fig. 4a

3.3 Clearances (Fig. 4a)

1. Any combustible material must be at least 300mm away from the stove or flue pipe.
2. The wall or surround to each side of the stove must be flat and unobstructed for at least 300mm.
3. Any shelf above the stove must be at least 300mm away from the stove or flue pipe.
4. No curtains should be within 380mm of the stove or flue pipe when they are in any position.

3.4 Flues

1. The chimney or flue system must be suitable for a Class 1 or Class 2 appliance, as defined by the Building Regulations.
2. It must have an internal diameter of minimum 125mm or equivalent.
3. Generally brick or block built chimneys, pre-cast flues or fabricated flues will meet these requirements.
4. The flue must be a minimum of 4m high, measured from the hearth to the point of termination. The flue must be fitted with a suitable pot or cowl with an internal diameter not less than 125mm.
5. Any obstructions, damper plates or flue restrictors must be removed before installation.
6. If the flue is not sound or in good condition a liner of not less than 125mm internal diameter and conforming to BS 715 must be fitted.
7. The flue must be swept before installation and any underfloor air supply beneath the stove sealed off.
8. It is essential that there is a positive pull up the flue or chimney. If there is not, **DO NOT** fit the stove. Seek expert advice before continuing with the installation.

3.5 Gas Supply & Connection

1. Determine where the gas supply is to be connected to the appliance. This may be done from either the left or right side, from the front, or a concealed fitting from the rear.

Turn off any appliances that are fed by the meter and isolate the gas supply by turning off at the meter.

2. The inlet elbow of the stove will accept 8mm OD tubing (Fig. 5).
3. A suitable isolating cock and disconnecting union should be always be fitted in the supply feed to the fire to facilitate servicing.

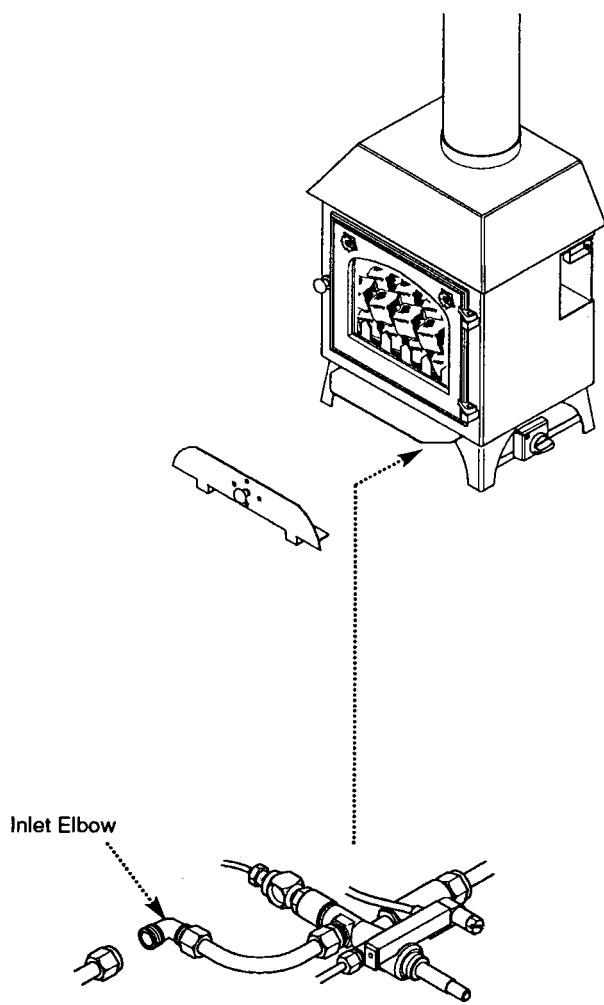
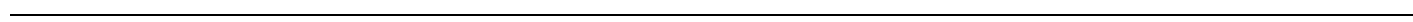

Fig. 5



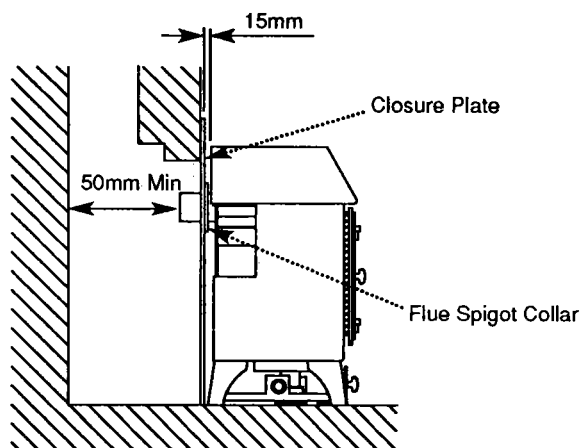
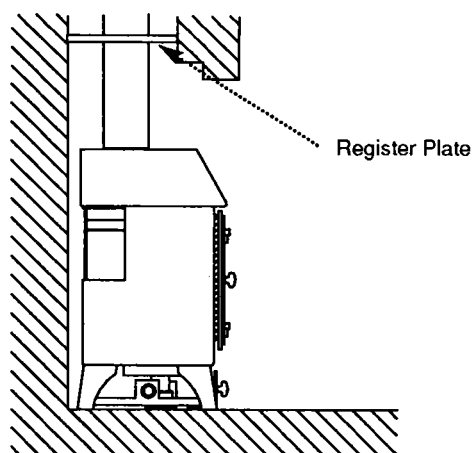

Fig. 6

4.1 Initial Preparation

1. After unpacking the appliance, carefully remove all items from inside the stove.
2. Care must be exercised when handling the appliance to prevent damage to the paint finish. Avoid touching the appliance with greasy or dirty hands

4.2 Top Flue Outlet Stoves

1. These models must be connected to the flue or chimney with a suitable length of 125mm diameter vitreous enamelled flue pipe fitted inside the spigot on top of the stove.
2. The flue pipe must be fitted through a register plate of fireproof material. All joints must be sealed.

4.3 Rear Flue Outlet Stoves (Fig. 6)

1. These models may be fitted to a builders opening, class 2 starter block or flue starter box, using the closure plate supplied.
2. The closure plate must be sealed along all edges. No air relief vent is necessary.
3. If necessary the closure plate can be cut down providing the fireplace opening is fully covered.
4. A minimum clearance of 50mm is required between the end of the flue spigot and rear face of the flue or opening.
5. The rear of the stove must not touch the closure plate, a gap of at least 15mm being required. The flue spigot collar ensures this dimension.

4.4 Fitting the Stove

1. Position the stove in the installation, and in the case of top flue outlet models, connect the flue pipe.
2. When positioning the stove, care must be exercised not to mark the hearth.
3. Purge the gas supply and connect it to the stove inlet elbow (Fig. 7). Check for gas soundness with leak detection fluid (to BS 6891).

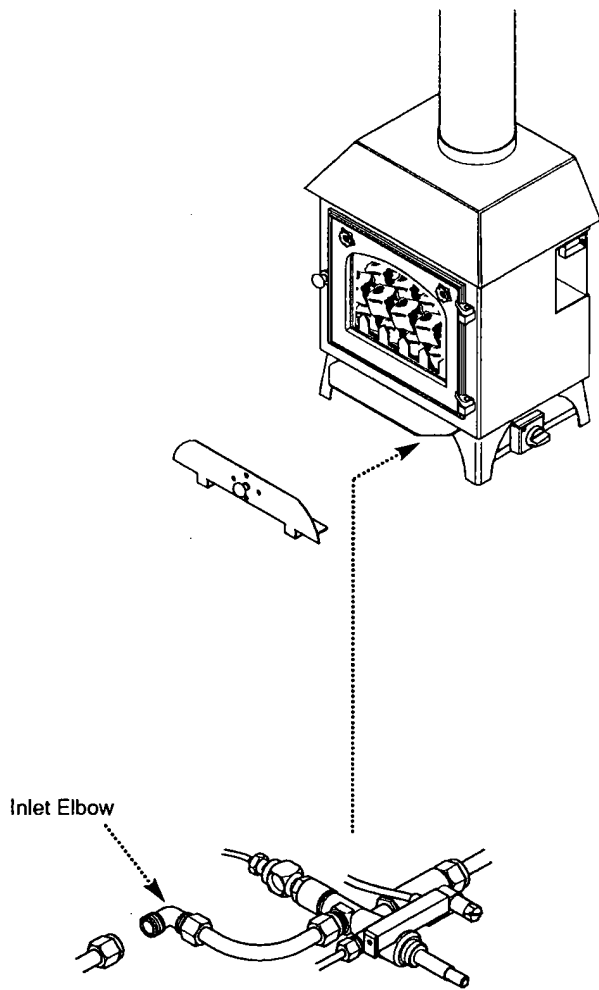

Fig.7

5.1 Arranging the Coals

It is important that all the coals are used and arranged as shown in order to achieve the desired flame picture.

CAUTION: The coals are extremely fragile and must be handled accordingly. To avoid soiling ones hands, gloves should be worn and any inhalation of the dust should be avoided. Keep the coals away from children at all times. Never use coals other than those supplied or Genuine Baxi Spare Parts. Never put additional coals on the stove. Please read section 1.3 Important Information.

5.2 Grasmere

1. Remove the coal guard (Fig. 8).
2. Carefully unpack the ceramic base (Fig. 9). Locate this in the stove, resting on the two supports (Fig. 10 & 13).
3. Replace the coal guard (Fig. 10).
4. Three types of coal are supplied with the Grasmere, 13 small coals with location holes, 14 standard small coals and 2 large coals.
5. Take the 13 small coals and locate them on the pegs on the ceramic base (Fig. 11).
6. The two large coals should be placed between the outer two coals on the back row and the ceramic sidecheeks (Fig. 12).
7. Place the remaining 14 standard coals over the gaps between the other small coals (Fig. 13).
8. Close the appliance door and secure it with the brass knob (Fig. 14).

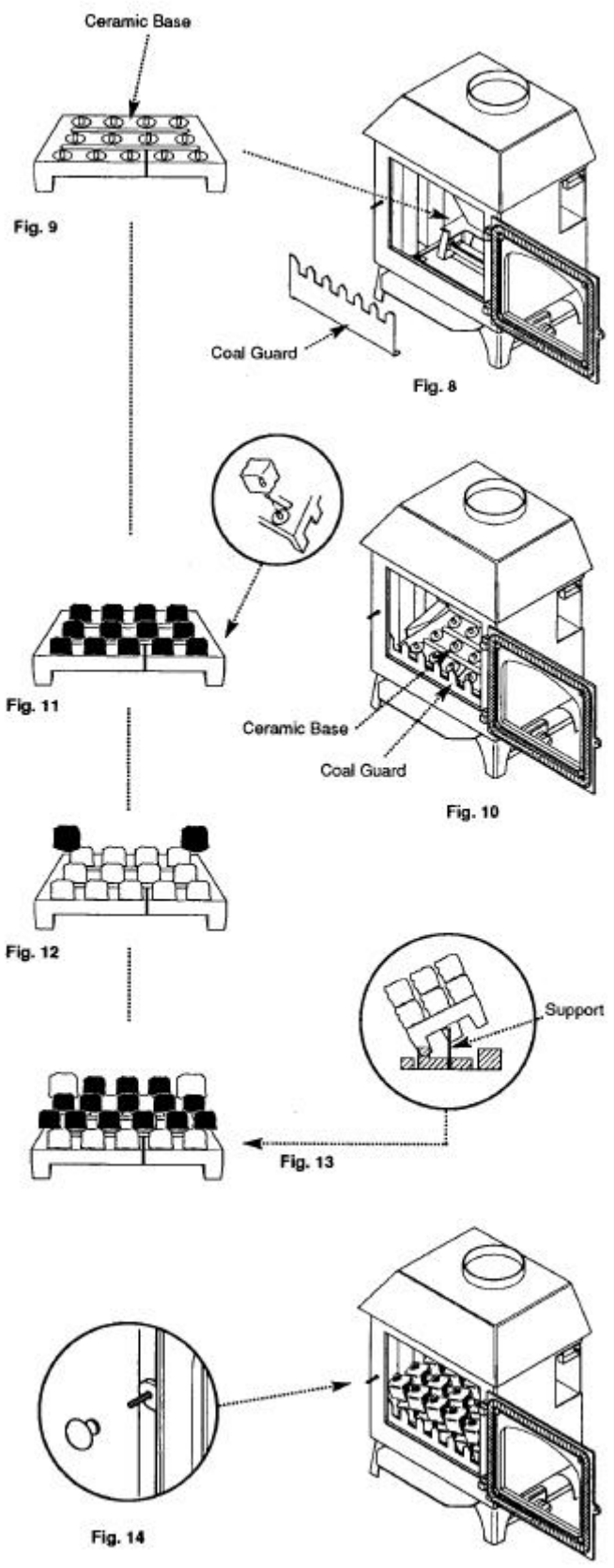

5.3 Windermere

1. Carefully unpack the ceramic base and place it centrally over the burner (Fig. 15).
2. Two types of coal are supplied with the Windermere, 24 small coals with location holes, 18 large coals.
3. Take the 24 small coals and locate them on the pegs on the ceramic base (Fig. 16).
4. Place six of the large coals between the middle row and back row and a further six between the middle and front row (Fig. 17).
5. The final six large coals should be placed between the door of the stove and the ceramic base (Fig. 18).
6. Close the appliance door and secure it with the brass knob (Fig. 19).

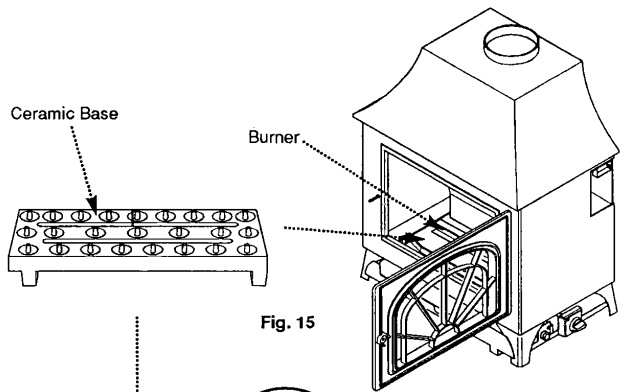

Fig. 15

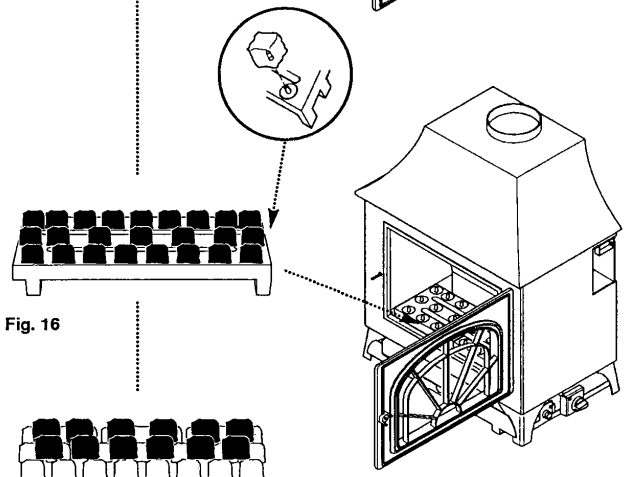

Fig. 16



Fig. 17

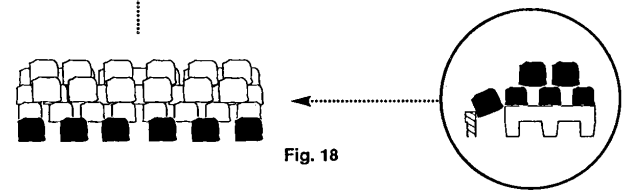

Fig. 18

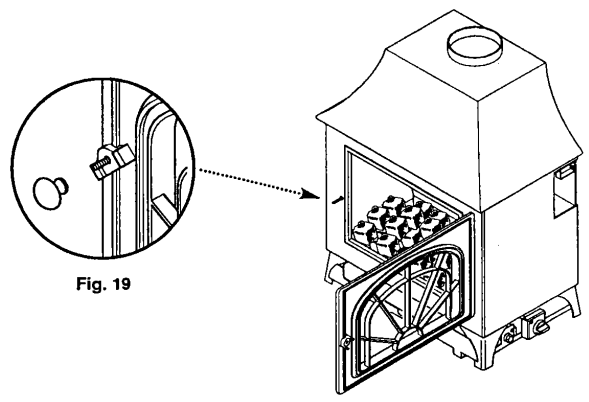

Fig. 19

5.4 Cleaning

1. Carefully clean the stove with a soft lint free duster or cloth. **DO NOT USE** any abrasive cleaning agents, solvents or similar when cleaning.
2. Clean any debris from around and underneath the stove.

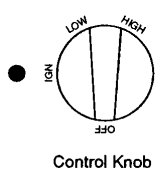
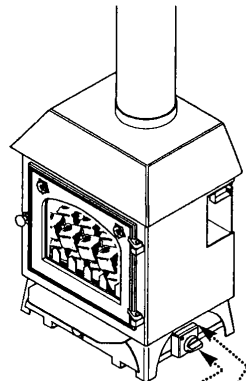

Fig. 21

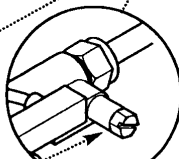

Fig. 20

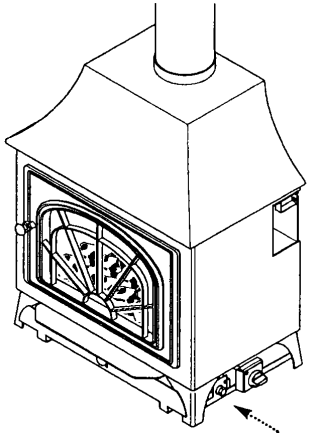
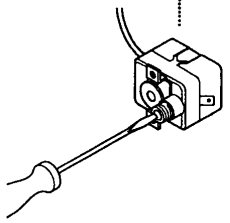
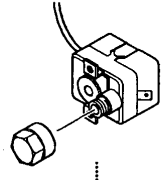

Fig. 22



6.1 Checking Gas Soundness

1. Turn on the gas supply and check for gas soundness with leak detection fluid (to BS 6891).

6.2 Checking Operation of the Stove

1. Remove the screw from the pressure test point on the gas tap (adjacent to the control knob) and fit a pressure gauge (Fig. 20).
2. Purge the air from the appliance by pushing in the control knob and rotating to the ignition position (Fig. 21). Allow the air in the pipework to be purged, and then rotate the knob further to operate the piezo igniter. The pilot should light.
3. Once the pilot is established push the control knob in and turn to the HIGH setting. Check the setting pressure. (Setting pressure detail found in Section 2.0 Technical Data.)
4. Turn the control knob to the OFF position, disconnect the pressure gauge and refit the pressure test point sealing screw.

6.3 Spillage Monitoring Device (Fig. 22)

1. The stove incorporates a spillage monitoring device. This will cut off the gas supply in the event of spillage of combustion products into the room.
2. In the event of this occurring there is a reset procedure. Wait for 10 minutes before trying to reset the stove.
3. Unscrew the cap off the reset device and press in the red button with a small screwdriver or similar instrument.
4. Relight the stove as previously described. If this is not possible, wait a further 5 minutes before pressing the red button. If this fails, wait until the stove is completely cool and reset it.
5. If the stove cannot be re-set or the spillage monitoring device is frequently activated the flue condition must be investigated.

WARNING: The spillage monitoring device must not be adjusted in any way. The spillage monitoring device must not be altered so that it will not operate or be bypassed in any way. Only use genuine Baxi spare parts.

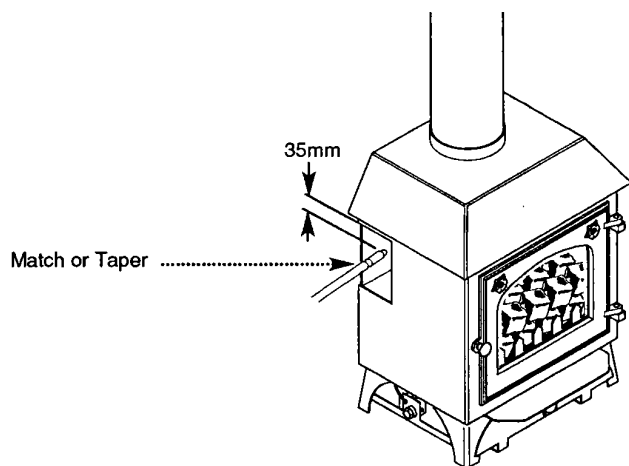

Fig. 23

7.1 Checking for Spillage

CAUTION - Whilst checking for spillage care must be taken to avoid touching hot panels.

1. Before starting the test, close all doors and windows.
2. Operate the stove from cold at maximum input.
3. After approximately 5 minutes check for spillage.
4. Insert a lighted smoke match in the draught diverter at the left hand side. The match should be positioned 35mm from the top edge of the diverter (Fig. 23). All the smoke should be drawn into the diverter. If not, wait a further 5 minutes and repeat the test.
5. If the test is successful repeat with any extractor fan on. If a connected room has an extractor fan, the test should be repeated with this fan on and any connecting doors open.
6. If spillage occurs and the problem cannot be rectified the stove must be isolated until the problem is resolved.

7.2 Possible causes of Spillage

1. The smoke match may have been positioned incorrectly, resulting in the smoke being picked up by hot convected air currents.
 2. The flue installation may be unsound.
 3. Down draughts may be present.
 4. Flue blockages.
 5. Rear flue - closure plate not sealed, stove not close enough to closure plate.
 6. Top flue – flue pipe not sealed to stove spigot.
-

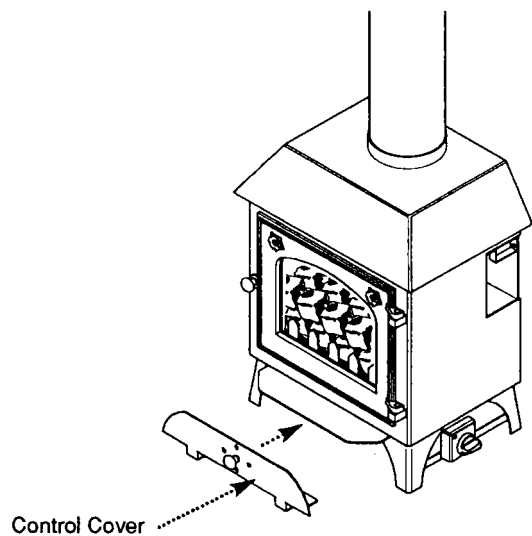

Fig. 24

8.1 Completion

1. Unpack the controls cover and place it centrally underneath the stove (Fig. 24).
2. These instructions and the users instructions should be handed to the customer. At the same time the customer should be shown how to operate the stove safely and efficiently.
3. The need for annual servicing should be emphasised and the returning of the guarantee card advised.

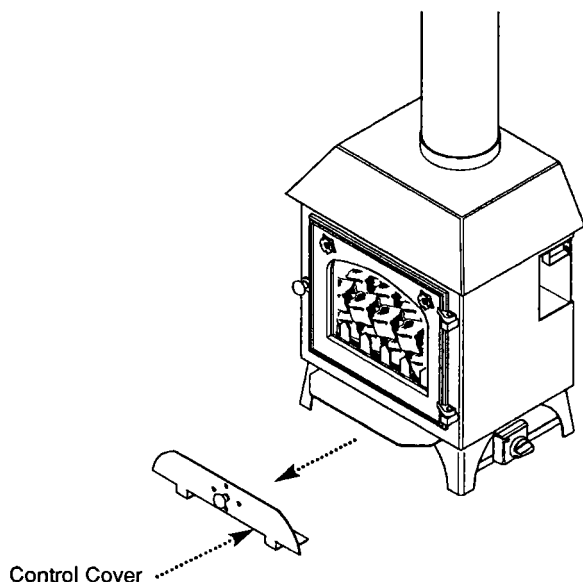

Fig. 25

9.1 Maintenance

IMPORTANT: It is possible that some soot may be deposited on the coals after use. This is acceptable providing it is not allowed to accumulate.

CAUTION: The coals are extremely fragile and must be handled accordingly. To avoid soiling ones hands, gloves should be worn and any inhalation of the dust should be avoided. Keep the coals away from children at all times. Never use coals other than those supplied or Genuine Baxi Spare Parts. Never put additional coals on the stove. Please read section 1.3 Important Information.

1. Servicing should be carried out regularly by a competent person in accordance with the relevant regulations, to ensure the safe and correct operation of the appliance.
2. Before commencing any service or replacement of parts, turn off the gas supply to the stove and ensure that the stove is cold.
3. After servicing, check for gas soundness.
4. When ordering spare parts please quote appliance name and serial number. These can be found on the data badge which is located by removing the controls cover (Fig. 25). The badge is behind the cover and fixed to the burner.
5. At least once a year check for debris in the catchment area behind the stove (RF models) and in the flueway.
6. If soot has accumulated in the flue or catchment area, check to establish the cause. Rectify and clean flue or chimney accordingly.
7. The coals may be removed for cleaning. The coals are delicate and should be handled carefully. Gently brush with a soft brush to remove dust or deposits.
8. Examine the coals for signs of cracking and replace if necessary.

IMPORTANT: See coal layout procedure (Section 5.0 Arranging the Coals) before attempting to replace coals.

9. Do not clean pilot jet or injectors using pins or wire.

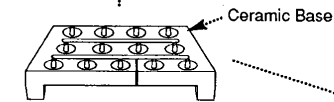

Fig. 28



Fig. 29



Sidecheek

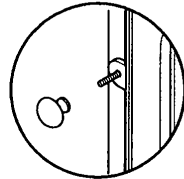
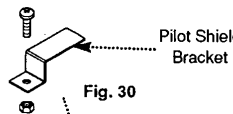

Fig. 26



Pilot Shield Bracket

Fig. 30

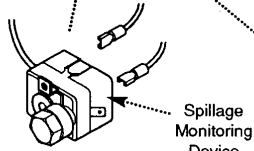
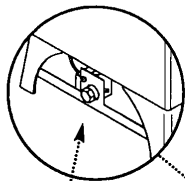
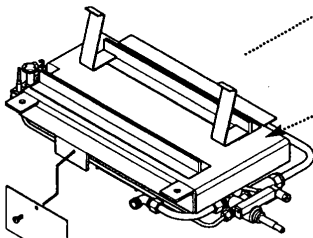

Fig. 33



Burner/Controls Assembly (inlays removed for clarity)

Data Badge

Fig. 32

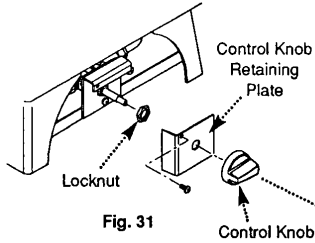

Fig. 31

Control Knob Retaining Plate

Control Knob

Locknut

9.2 Preparation

1. For reasons of safety and economy it is important to service the stove annually.

WARNING: Isolate the gas supply to the appliance before servicing.

2. For Grasmere models see section 9.3 Grasmere.
3. For Windermere models see section 9.4 Windermere.

9.3 Grasmere

1. Unscrew the brass door knob and open the door (Fig. 26).
2. Remove the coal guard (Fig. 27) and remove all the coals.
3. Manoeuvre the ceramic base (Fig. 28) out of the stove and place carefully to one side.
4. Remove the two sidecheeks, noting their orientation (Fig. 29).
5. Undo the screw and nut retaining the pilot shield bracket and remove the bracket (Fig. 30).
6. Undo the disconnecting union on the gas supply.
7. Pull the control knob off the tap and undo the screw retaining the plate (Fig. 31).
8. Undo the brass locknut holding the tap to the mounting bracket (Fig. 31).
9. Undo the screw and remove the data badge plate (Fig. 32).
10. Disconnect the two leads from the spillage monitoring device (Fig. 33).
11. Carefully manoeuvre the burner/controls assembly out of the stove (Fig. 32).

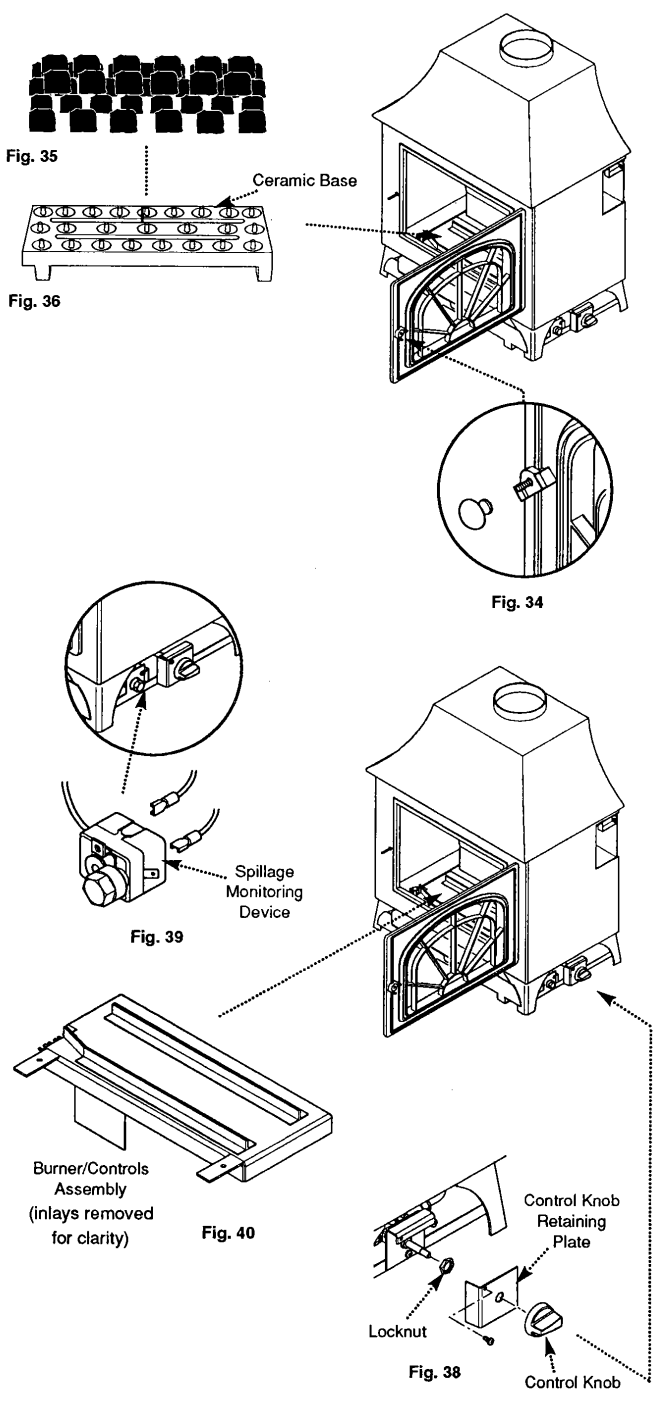

9.4 Windermere

1. Unscrew the brass knob and open the door (Fig. 34).
2. Remove all the coals and manoeuvre the ceramic base out of the stove and place carefully to one side (Fig. 35 & 36).
3. Undo the disconnecting union on the gas supply.
4. Pull the control knob off the tap and undo the screw retaining the plate (Fig. 38).
5. Undo the brass locknut holding the tap to the mounting bracket (Fig. 38).
6. Disconnect the two leads from the spillage monitoring device (Fig. 39).
7. Carefully manoeuvre the burner/controls assembly out of the stove (Fig. 40).

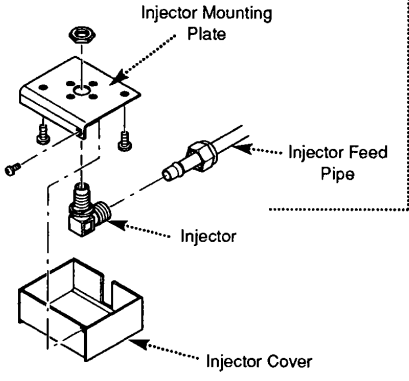
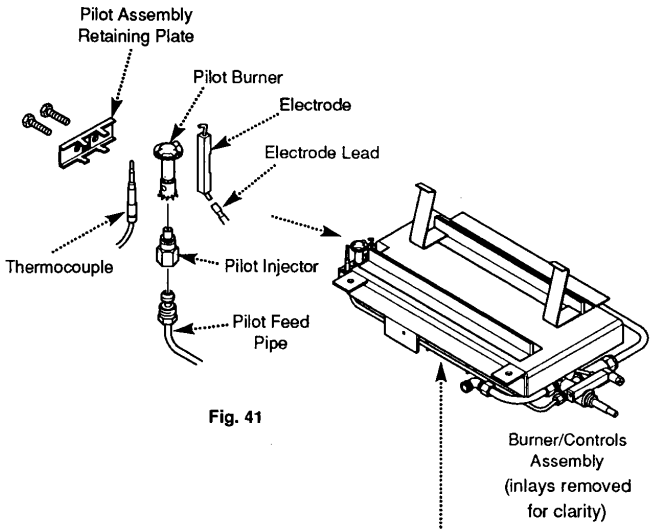

9.5 Cleaning the Pilot (Fig. 41)

1. Undo the feed pipe from the pilot injector and pull the lead off the ignition electrode.
2. Undo the two screws holding the pilot assembly retaining plate. Remove the plate and withdraw the electrode and pilot burner. Note the orientation of the pilot burner outlet ports.
3. Pull the pilot injector from the burner and clean carefully. Do not use pins or wires
4. Clean the pilot burner and electrode.

9.6 Cleaning the Burner and Injector (Fig. 42)

1. Undo the screw retaining the injector cover to the injector mounting plate and remove the cover. Undo the nut on the injector feed pipe at the injector.
2. Remove the two screws securing the injector mounting plate to the burner and undo the locknut retaining the injector to the plate.
3. Carefully clean the injector with a soft brush.
4. Carefully brush the burner and ceramic inlays. Care must be taken not to damage the inlays.

9.7 Completing Servicing

1. Examine the thermocouple and replace if necessary (Fig. 41).
2. Clean any dirt and debris from the combustion box, builders opening and the hearth under the stove. Please read section 1.3 Important Information.
3. Reassemble the stove in reverse order of dismantling. On RF models reseal the closure plate and reposition the stove at least 15mm away from the plate.
4. Recommission the stove as described in section 6.0 Commissioning the Stove.

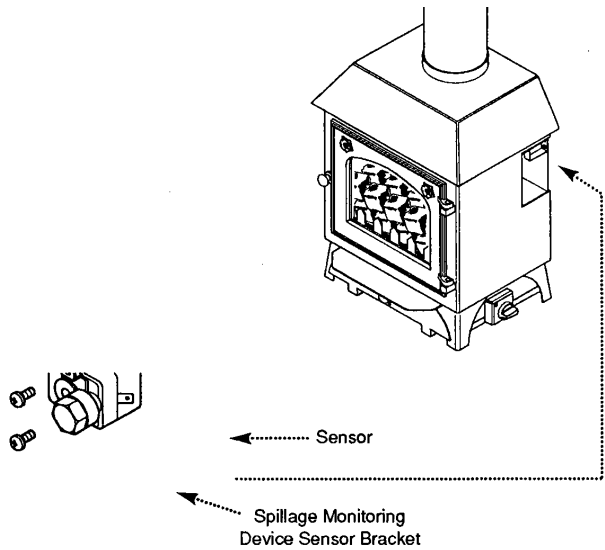

Fig. 43

10.1 Changing Components

WARNING: Before changing any components, ensure that the stove is cool and that the gas supply is isolated.

10.2 Spillage Monitoring Device

(Figs. 43 & 44)

1. Undo the nut and screw holding the monitoring device sensor bracket to the draught diverter.
2. Withdraw the sensor from the bracket.
3. Pull the two wires off the sensor body and undo the screws holding the body to the appliance.
4. Remove the spillage monitoring device from the appliance.
5. Refit the new device in reverse order, carefully routing the capillary so as it does not touch any hot panels.

WARNING: The spillage monitoring device must not be adjusted in any way. The spillage monitoring device must not be altered so that it will not operate or be bypassed in any way. Always use a Genuine Baxi Spare Part.

TO CHANGE ANY GAS CONTROL COMPONENTS. IT IS NECESSARY TO REMOVE THE COMPLETE CONTROLS ASSEMBLY. SEE SUB-SECTION 9.2 PREPARATION OF 9.0 ANNUAL SERVICING

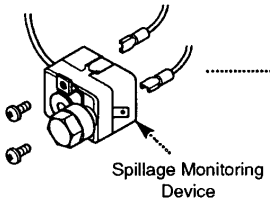
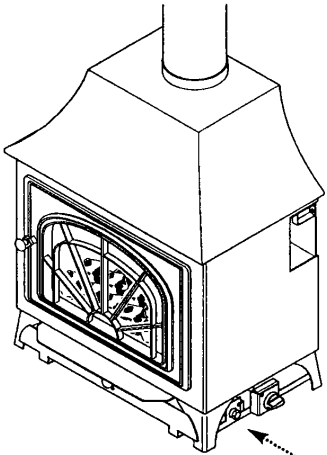
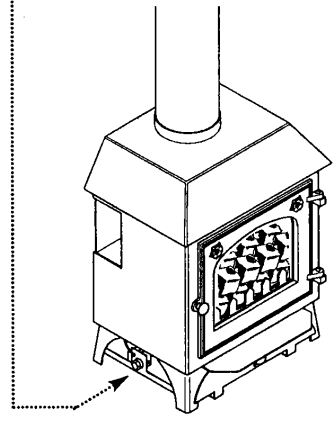

Fig. 44



10.3 Gas Tap, Igniter and FFD

NOTE: The tap incorporates a flow setting device on its outlet connection. This is factory set and must not be adjusted.

1. Pull the electrode lead off the electrode (Fig. 45).
2. Undo the thermocouple nut from the interrupter unit and pull off the two leads (Fig. 46).
3. Undo the pilot feed nut and the gas inlet and outlet nuts from the tap assembly (Fig. 46).
4. Note the orientation of all the pipes and remove them.
5. Remove the gas tap (Fig. 46).
6. Remove the interrupter unit from the gas tap (Fig. 46).
7. Refit in reverse order of dismantling, ensuring that the thermocouple nut is done up tight in the interrupter unit.

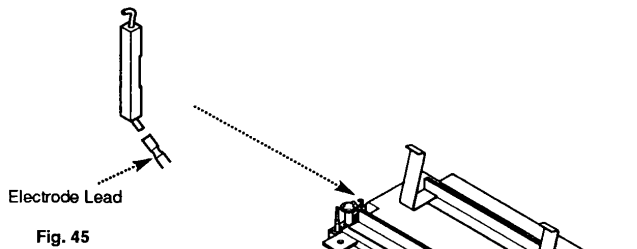

Fig. 45

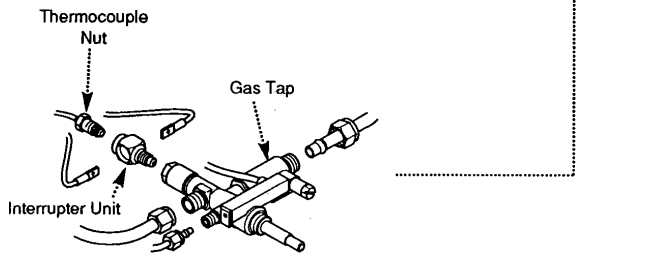

Fig. 46

10.4 Injector (Fig. 47)

1. Undo the screw retaining the injector cover to the injector mounting plate and remove the cover.
2. Undo the nut on the injector feed pipe at the injector.
3. Remove the two screws securing the injector mounting plate to the burner and undo the locknut retaining the injector to the plate.
4. Fit the new component and reassemble in reverse order of dismantling.

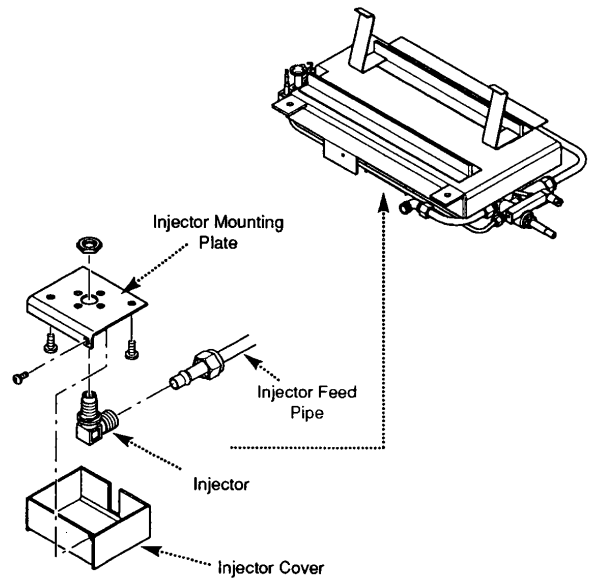

Fig. 47

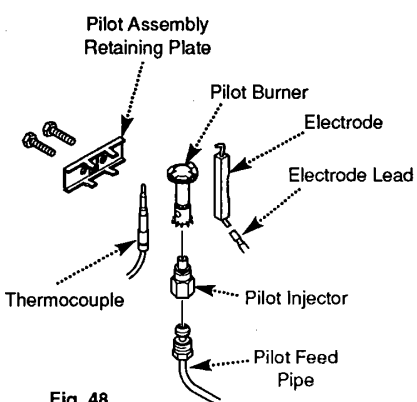

Fig. 48

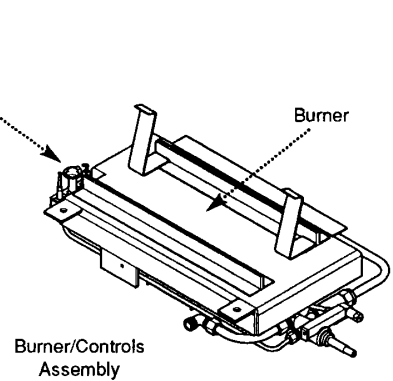

Fig. 50

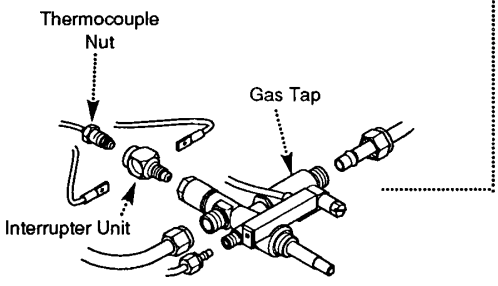

Fig. 49

10.5 Electrode (Fig. 48)

1. Pull the lead off the electrode and undo the two screws holding the pilot retaining plate.
2. Note the orientation of the electrode, withdraw it and refit the new component in reverse order of dismantling.

10.6 Thermocouple (Figs. 48 & 49)

1. Undo the thermocouple nut from the interrupter unit and remove the two screws holding the pilot retaining plate.
2. Remove the thermocouple and shape the new one in a similar manner to the original.
3. Fit the new component in reverse order of dismantling.

10.7 Pilot Burner and Injector (Fig. 48)

1. Undo the pilot feed pipe nut from the pilot injector.
2. Undo the two screws holding the pilot assembly retaining plate, noting the orientation of the pilot burner outlet ports.
3. Withdraw the pilot injector and burner. The injector can now be removed from the burner.
4. Replace either or both components as required and reassembly in reverse order of dismantling.

10.8 Burner (Fig. 50)

1. Remove all other control components as described in sections 10.3 through to 10.7.
2. Fit all the previously removed control components to the new burner.
3. Reassemble all components in reverse order and recommission the appliance.

11.1 Fault Finding

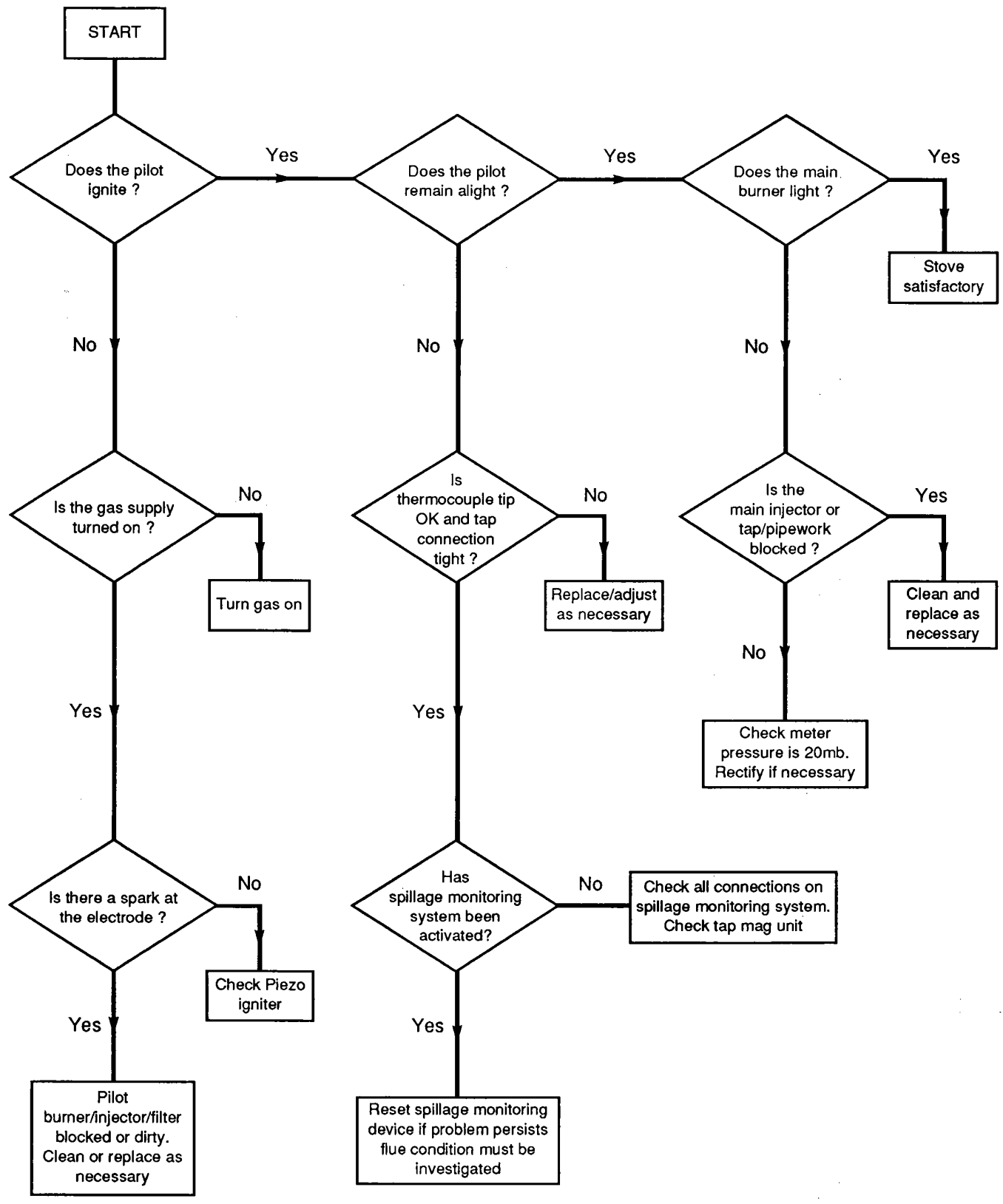

12.1 Short Parts List

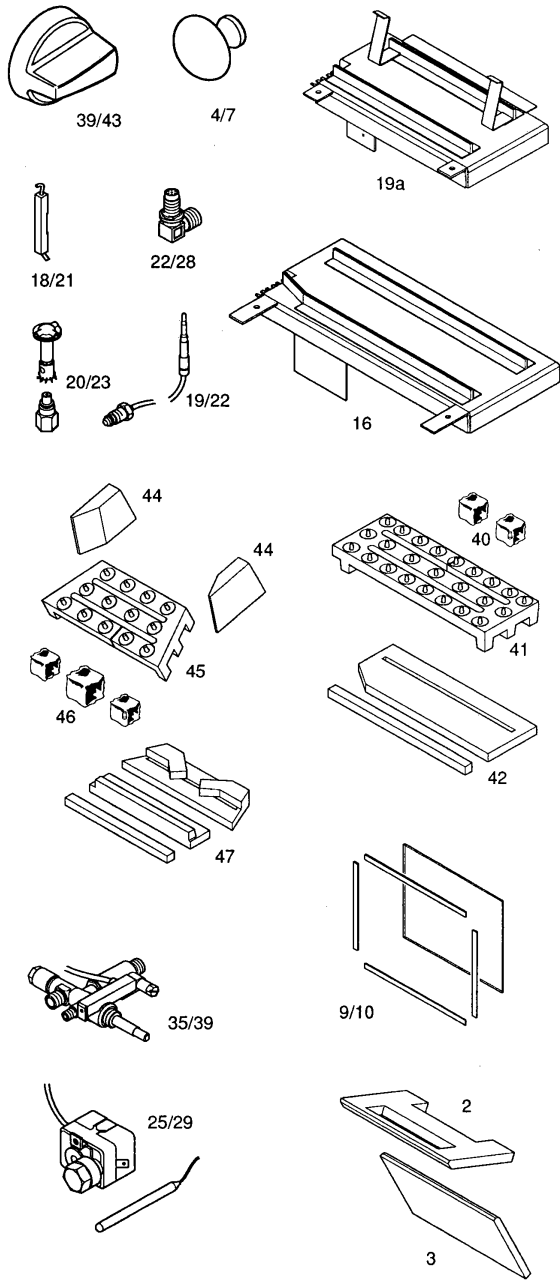

Key No.	G.C. No	Description	Manuf 's Part No.
19a	E37 444	Main Burner - Grasmere	242675
16	E39 307	Main Burner - Windermere	242676
39	E37 468	Gas Tap-inc. Lead - Grasmere	242677
35	E39 314	Gas Tap-inc. Lead - Windermere	242678
20/23	E37 448	Pilot Burner Kit	242679
28	E37 452	Main Injector - Grasmere	242681
22	E39 310	Main Injector - Windermere	242682
25/29	E37 450	Spillage Monitoring Device	242683
47	E37 475	Burner Inlays - Grasmere	242684
42	E39 327	Burner Inlays - Windermere	242685
45	E37 473	Base - Grasmere	242686
41	E39 326	Base - Windermere	242687
46	E37 474	Kit- Coals - Grasmere	242690
44	E37 472	Side Cheeks - Grasmere	242691
3	E37 425	Rear Ceramic - Grasmere	242692
2	E37 424	Top Ceramic - Grasmere	242693
9	E37 433	Door Glass Kit - Grasmere	242694
10	E39 300	Door Glass Kit - Windermere	242695
39/43	E37 471	Control Knob	242696
4/7	E37 431	Brass Door Knob	242697
19/22	E37 447	Thermocouple - Stove	242698
18/21	E37 445	Electrode - Stove	242699
40	E39 324	Kit -Loose Coals - Windermere	242700

13.1 Windermere Propane Models

1. Most aspects of the Propane Models are the same as Natural Gas, with the exception of the following:

The gas type is G31 (Propane)

The supply pressure is 37mbar

(Max)	Heat Input	7.5kW (25,590 Btu/h)
(Min)	Heat Input	5.2kw (17,742 Btu/h)
(Max)	Heat Output	5.6kw (19,116 Btu/h)
	Burner Pressure	28.5mbar (11.4 in wg)

2. The following spares components differ from natural gas models:

Injector	242704
Ceramic burner inlay	242705
Burner	242706
Pilot Injector	242707

3. **This appliance is designed for use on Propane and must not be used with any other gas.**

[Click here for Helplines](#)